



Technical Specifications

Technical Specifications



PUERTO RICO
INDUSTRIAL DEVELOPMENT COMPANY
PRIDCO

PRIDCO-FEMA 4339 DR Program North Region - Bid Package N1-2

PW 8004	DI 219020
PW 8004	DI 219021
PW 8004	DI 219022
PW 8004	DI 219023
PW 8004	DI 219024



CSA GROUP
EST • 1956

Division	Section Title	Pages
----------	---------------	-------

SPECIFICATIONS GROUP

General Requirements Subgroup

DIVISION 01 - GENERAL REQUIREMENTS

011000	SUMMARY	4
013300	SUBMITTAL PROCEDURES	7
014000	QUALITY REQUIREMENTS	9
015000	TEMPORARY FACILITIES AND CONTROLS	12

Facility Construction Subgroup

DIVISION 02 - EXISTING CONDITIONS

024119	SELECTIVE DEMOLITION	5
--------	----------------------	---

DIVISION 03 - CONCRETE

030130	MAINTENANCE OF CAST-IN-PLACE CONCRETE	5
033000	CAST-IN-PLACE CONCRETE	13

DIVISION 05 - METALS

051200	STRUCTURAL STEEL FRAMING	2
052100	STEEL JOIST FRAMING	2
053100	STEEL DECKING	2
055111	ALUMINUM LADDERS	2
055116	METAL FLOOR PLATE STAIRS	9
055213	PIPE AND TUBE RAILINGS	6

DIVISION 07 - THERMAL AND MOISTURE PROTECTION

070150.19	PREPARATION FOR REROOFING	5
074646	FIBER-CEMENT SIDING	2
075552.16	STYRENE-BUTADIENE-STYRENE (SBS) MODIFIED BITUMINOUS PROTECTED MEMBRANE ROOFING	9

DIVISION 08 - OPENINGS

081113	HOLLOW METAL DOORS AND FRAMES	5
081416	FLUSH WOOD DOORS	4
083323	OVERHEAD COILING DOORS	5
085113	ALUMINUM WINDOWS	4
087111	DOOR HARDWARE (DESCRIPTIVE SPECIFICATION)	9

DIVISION 09 - FINISHES

092216	NON-STRUCTURAL METAL FRAMING	4
092400	CEMENT PLASTERING	4

099113	EXTERIOR PAINTING	6
099123	INTERIOR PAINTING	7
099653	ELASTOMERIC COATINGS	3

Facility Services Subgroup

DIVISION 22 – PLUMBING

220500	COMMON WORK RESULTS FOR PLUMBING	6
220517	SLEEVES AND SLEEVE SEALS FOR PLUMBING PIPING	4
220529	HANGERS AND SUPPORTS FOR PLUMBING PIPING AND EQUIPMENT	6
221116	DOMESTIC WATER PIPING	9
221414	STORM DRAINAGE PIPING	7
221423	STORM DRAINAGE PIPING SPECIALTIES	5

DIVISION 23 - HEATING, VENTILATING, AND AIR CONDITIONING (HVAC)

233416	CENTRIFUGAL HVAC FANS	5
--------	-----------------------	---

DIVISION 26 - ELECTRICAL

262416	PANELBOARDS	6
265619	LED EXTERIOR LIGHTING	5

Site and Infrastructure Subgroup

DIVISION 31 - EARTHWORK

311000	SITE CLEARING	4
312000	EARTH MOVING	9

DIVISION 32 - EXTERIOR IMPROVEMENTS

321216	ASPHALT PAVING	6
321313	CONCRETE PAVING	7
321713	PARKING BUMPERS	2
321723	PAVEMENT MARKINGS	2
323113	CHAIN LINK FENCES AND GATES	5

END OF TABLE OF CONTENTS

SECTION 011000 - SUMMARY

PART 1 - GENERAL

1.1 SUMMARY

A. Section Includes:

1. Project information.
2. Work covered by Contract Documents.
3. Contractor's use of site and premises.
4. Coordination with occupants.
5. Work restrictions.
6. Specification and Drawing conventions.

B. Related Requirements:

1. Section 015000 "Temporary Facilities and Controls" for limitations and procedures governing temporary use of Owner's facilities.

1.2 PROJECT INFORMATION

A. Project Identification: PRIDCO-FEMA 4339 DR Program - Repair and Improvements of Industrial Buildings of PRIDCO – North Region- Stage 1 Bid Package N1-2.

1. Project Location:

- a. Cibuco Ward L-153-0-58-00 Corozal, Puerto Rico - Bldg #T078906600 (PW 8004 DI 219020)
- b. Cibuco Ward, Corozal, Puerto Rico - Bldg #T090306800 (PW 8004 DI 219021)
- c. Cibuco Ward, Corozal, Puerto Rico - Bldg #T090407000 (PW 8004 DI 219022)
- d. Cibuco Ward, Corozal, Puerto Rico - Bldg #T090506800 (PW 8004 DI 219023)
- e. Cibuco Ward, Corozal, Puerto Rico - Bldg #T123007700 (PW 8004 DI 219024)

B. Owner: PRIDCO, 355 Ave FD Roosevelt, Edificio Fomento Industrial, Suite 404, San Juan, PR 00918

1. Owner's Representative: Eng. Santiago R. Garcia Melendez, PE
santiago.garcia@pridco.pr.gov

C. Architect: CSA Architects & Engineers, LLP, 1511 Ponce de Leon Ave, Suite 23, San Juan, PR 00909.

1. Architect's Representative: Arch. Annette Alfonso Diaz, aalfonso@csagroup.com

D. Contractor: <Insert name of Contractor firm> has been engaged as Contractor for this Project.

1. Contractor Representative: <Insert name and contact information for Contractor representative>.
- E. Construction Manager: ROV Engineering Services, PSC, 100 Road 165, Suite 203 CIM Tower 1, Guaynabo, PR 00968
1. Construction Manager Representative: Eng Luis Colon, PE, lcolon@rovengineering.com
 2. Construction Manager has been engaged for this Project to serve as an advisor to Owner and to provide assistance in administering the Contract for construction between Owner and Contractor, according to a separate contract between Owner and Construction Manager.
- F. Web-Based Project Software: Project software will be used for purposes of managing communication and documents during the construction stage.
1. Coordinate with Construction Manager for information on Project software.

1.3 WORK COVERED BY CONTRACT DOCUMENTS

- A. The Work of Project is defined by the Contract Documents and consists of the following:
1. Construction repairs to existing buildings and sites including, but not limited to, building walls and finishes, windows, doors, overhangs, structural elements, access stairs/ramps and railings, roof waterproofing system and accessories, roof mounted equipment such as exhaust fans, electrical system as main panel and transformers, equipment such as rolling gates, restrooms facilities, perimeter fences and gates, pavement, sidewalk, site drainage structures and other Work indicated in the Contract Documents.
- B. Type of Contract:
1. Project will be constructed under a single prime contract.

1.4 CONTRACTOR'S USE OF SITE AND PREMISES

- A. Restricted Use of Site: Contractor shall have limited use of Project site for construction operations.
- B. Limits on Use of Site: Limit use of Project site to Work in areas indicated. Do not disturb portions of Project site beyond areas in which the Work is indicated.
1. Limits on Use of Site: Confine construction operations to areas designated by Construction Manager. Use of other areas of site for construction operations is prohibited.
 2. Owner Occupancy: Allow for Owner and Tenant occupancy of site and use by the public.
 3. Driveways, Walkways, and Entrances: Keep driveways loading areas, and entrances serving premises clear and available to Owner, Owner's employees, and emergency vehicles at all times. Do not use these areas for parking or for storage of materials.

- C. Condition of Existing Building: Maintain portions of existing building affected by construction operations in a weathertight condition throughout construction period. Repair damage caused by construction operations.
- D. Condition of Existing Grounds: Maintain portions of existing grounds, landscaping, and hardscaping affected by construction operations throughout construction period. Repair damage caused by construction operations.

1.5 COORDINATION WITH OCCUPANTS

- A. Full Owner Occupancy: Owner will occupy site and existing building(s) during entire construction period. Cooperate with Owner during construction operations to minimize conflicts and facilitate Owner usage. Perform the Work so as not to interfere with Owner's day-to-day operations. Maintain existing exits unless otherwise indicated.

1.6 WORK RESTRICTIONS

- A. Comply with restrictions on construction operations.
 - 1. Comply with limitations on use of public streets, work on public streets, rights of way, and other requirements of authorities having jurisdiction.
- B. On-Site Work Hours: Limit work in the existing building to normal business working hours of 7:30 a.m. to 4:30 p.m., Monday through Friday, unless otherwise indicated.
- C. Existing Utility Interruptions: Do not interrupt utilities serving facilities occupied by Owner or others unless permitted under the following conditions and then only after providing temporary utility services according to requirements indicated:
 - 1. Notify Construction Manager not less than two days in advance of proposed utility interruptions.
 - 2. Obtain Owner's written permission before proceeding with utility interruptions.
- D. Noise, Vibration, Dust, and Odors: Coordinate operations that may result in high levels of noise and vibration, dust, odors, or other disruption to Owner occupancy with Owner.
 - 1. Notify Construction Manager not less than two days in advance of proposed disruptive operations.
 - 2. Obtain Construction Manager's written permission before proceeding with disruptive operations.
- E. Smoking and Controlled Substance Restrictions: Use of tobacco products, alcoholic beverages, and other controlled substances on Owner's property is not permitted.
- F. Employee Identification: Provide identification tags for Contractor personnel working on Project site. Require personnel to use identification tags at all times.
- G. Employee Screening: Comply with Owner's requirements for drug and background screening of Contractor personnel working on Project site.

1. Maintain list of approved screened personnel with Owner's representative.

1.7 SPECIFICATION AND DRAWING CONVENTIONS

- A. Specification Content: The Specifications use certain conventions for the style of language and the intended meaning of certain terms, words, and phrases when used in particular situations. These conventions are as follows:
 1. Imperative mood and streamlined language are generally used in the Specifications. The words "shall," "shall be," or "shall comply with," depending on the context, are implied where a colon (:) is used within a sentence or phrase.
 2. Text Color: Text used in the Specifications, including units of measure, manufacturer and product names, and other text may appear in multiple colors or underlined as part of a hyperlink; no emphasis is implied by text with these characteristics.
 3. Hypertext: Text used in the Specifications may contain hyperlinks. Hyperlinks may allow for access to linked information that is not residing in the Specifications. Unless otherwise indicated, linked information is not part of the Contract Documents.
 4. Specification requirements are to be performed by Contractor unless specifically stated otherwise.
- B. Division 00 Contracting Requirements: General provisions of the Contract, including General and Supplementary Conditions, apply to all Sections of the Specifications.
- C. Division 01 General Requirements: Requirements of Sections in Division 01 apply to the Work of all Sections in the Specifications.

PART 2 - PRODUCTS (Not Used)

PART 3 - EXECUTION (Not Used)

END OF SECTION 011000

SECTION 013300 - SUBMITTAL PROCEDURES

PART 1 - GENERAL

1.1 SUMMARY

- A. Section Includes:
 - 1. Submittal schedule requirements.
 - 2. Administrative and procedural requirements for submittals.

1.2 DEFINITIONS

- A. Action Submittals: Written and graphic information and physical samples that require Architect's responsive action. Action submittals are those submittals indicated in individual Specification Sections as "action submittals."
- B. Informational Submittals: Written and graphic information and physical samples that do not require Architect's responsive action. Submittals may be rejected for not complying with requirements. Informational submittals are those submittals indicated in individual Specification Sections as "informational submittals."

1.3 SUBMITTAL SCHEDULE

- A. Submittal Schedule: Submit, as an action submittal, a list of submittals, arranged in chronological order by dates required by construction schedule. Include time required for review, ordering, manufacturing, fabrication, and delivery when establishing dates. Include additional time required for making corrections or revisions to submittals noted by Architect and Construction Manager and additional time for handling and reviewing submittals required by those corrections.

1.4 SUBMITTAL FORMATS

- A. Submittal Information: Include the following information in each submittal:
 - 1. Project name.
 - 2. Date.
 - 3. Name of Architect.
 - 4. Name of Construction Manager.
 - 5. Name of Contractor.
 - 6. Name of firm or entity that prepared submittal.
 - 7. Names of subcontractor, manufacturer, and supplier.
 - 8. Unique submittal number, including revision identifier. Include Specification Section number with sequential alphanumeric identifier, and alphanumeric suffix for resubmittals.
 - 9. Category and type of submittal.

10. Submittal purpose and description.
 11. Number and title of Specification Section, with paragraph number and generic name for each of multiple items.
 12. Drawing number and detail references, as appropriate.
 13. Indication of full or partial submittal.
 14. Location(s) where product is to be installed, as appropriate.
 15. Other necessary identification.
 16. Remarks.
 17. Signature of transmitter.
- B. Options: Identify options requiring selection by Architect.
- C. Deviations and Additional Information: On each submittal, clearly indicate deviations from requirements in the Contract Documents, including minor variations and limitations; include relevant additional information and revisions, other than those requested by Architect and Construction Manager on previous submittals. Indicate by highlighting on each submittal or noting on attached separate sheet.
- D. Electronic Submittals: Prepare submittals as PDF package, incorporating complete information into each PDF file. Name PDF file with submittal number.
- E. Submittals for Utilizing Web-Based Project Management Software: Prepare submittals as PDF files, or other format indicated by Project management software.

1.5 SUBMITTAL PROCEDURES

- A. Prepare and submit submittals required by individual Specification Sections. Types of submittals are indicated in individual Specification Sections.
1. Email: Prepare submittals as PDF package and transmit to Architect by sending via email. Include PDF transmittal form. Include information in email subject line as requested by Architect.
 2. Web-Based Project Management Software: Prepare submittals in PDF form, and upload to web-based Project management software website. Enter required data in web-based software site to fully identify submittal.
- B. Coordination: Coordinate preparation and processing of submittals with performance of construction activities.
1. Coordinate each submittal with fabrication, purchasing, testing, delivery, other submittals, and related activities that require sequential activity.
 2. Submit all submittal items required for each Specification Section concurrently unless partial submittals for portions of the Work are indicated on approved submittal schedule.
 3. Submit action submittals and informational submittals required by the same Specification Section as separate packages under separate transmittals.
- C. Processing Time: Allow time for submittal review, including time for resubmittals, as follows. Time for review shall commence on Architect's receipt of submittal. No extension of the Contract Time will be authorized because of failure to transmit submittals enough in advance of the Work to permit processing, including resubmittals.

1. Initial Review: Allow 15 days for initial review of each submittal. Allow additional time if coordination with subsequent submittals is required. Architect will advise Contractor when a submittal being processed must be delayed for coordination.
 2. Resubmittal Review: Allow 15 days for review of each resubmittal.
- D. Resubmittals: Make resubmittals in same form and number of copies as initial submittal.
- E. Distribution: Furnish copies of final submittals to manufacturers, subcontractors, suppliers, fabricators, installers, authorities having jurisdiction, and others as necessary for performance of construction activities. Show distribution on transmittal forms.
- F. Use for Construction: Retain complete copies of submittals on Project site. Use only final action submittals that are marked with approval notation from Architect's action stamp.

1.6 SUBMITTAL REQUIREMENTS

- A. Product Data: Collect information into a single submittal for each element of construction and type of product or equipment.
1. If information must be specially prepared for submittal because standard published data are unsuitable for use, submit as Shop Drawings, not as Product Data.
 2. Mark each copy of each submittal to show which products and options are applicable.
 3. Include the following information, as applicable:
 - a. Manufacturer's catalog cuts.
 - b. Manufacturer's product specifications.
 - c. Standard color charts.
 - d. Statement of compliance with specified referenced standards.
 - e. Testing by recognized testing agency.
 - f. Application of testing agency labels and seals.
 - g. Notation of coordination requirements.
 - h. Availability and delivery time information.
 4. For equipment, include the following in addition to the above, as applicable:
 - a. Wiring diagrams that show factory-installed wiring.
 - b. Printed performance curves.
 - c. Operational range diagrams.
 - d. Clearances required to other construction, if not indicated on accompanying Shop Drawings.
 5. Submit Product Data before Shop Drawings, and before or concurrent with Samples.
- B. Shop Drawings: Prepare Project-specific information, drawn accurately to scale. Do not base Shop Drawings on reproductions of the Contract Documents or standard printed data.
1. Preparation: Fully illustrate requirements in the Contract Documents. Include the following information, as applicable:
 - a. Identification of products.

- b. Schedules.
 - c. Compliance with specified standards.
 - d. Notation of coordination requirements.
 - e. Notation of dimensions established by field measurement.
 - f. Relationship and attachment to adjoining construction clearly indicated.
 - g. Seal and signature of professional engineer if specified.
- C. Samples: Submit Samples for review of kind, color, pattern, and texture for a check of these characteristics with other materials.
1. Transmit Samples that contain multiple, related components such as accessories together in one submittal package.
 2. Identification: Permanently attach label on unexposed side of Samples that includes the following:
 - a. Project name and submittal number.
 - b. Generic description of Sample.
 - c. Product name and name of manufacturer.
 - d. Sample source.
 - e. Number and title of applicable Specification Section.
 - f. Specification paragraph number and generic name of each item.
 3. Email Transmittal: Provide PDF transmittal. Include digital image file illustrating Sample characteristics, and identification information for record.
 4. Web-Based Project Management Software: Prepare submittals in PDF form, and upload to web-based Project software website. Enter required data in web-based software site to fully identify submittal.
 5. Paper Transmittal: Include paper transmittal including complete submittal information indicated.
 6. Disposition: Maintain sets of approved Samples at Project site, available for quality-control comparisons throughout the course of construction activity. Sample sets may be used to determine final acceptance of construction associated with each set.
 - a. Samples that may be incorporated into the Work are indicated in individual Specification Sections. Such Samples must be in an undamaged condition at time of use.
 - b. Samples not incorporated into the Work, or otherwise designated as Owner's property, are the property of Contractor.
 7. Samples for Verification: Submit full-size units or Samples of size indicated, prepared from same material to be used for the Work, cured and finished in manner specified, and physically identical with material or product proposed for use, and that show full range of color and texture variations expected. Samples include, but are not limited to, the following: partial sections of manufactured or fabricated components; small cuts or containers of materials; complete units of repetitively used materials; swatches showing color, texture, and pattern; color range sets; and components used for independent testing and inspection.
 - a. Number of Samples: Submit three sets of Samples. Architect and Construction Manager will retain two Sample sets; remainder will be returned. Mark up and retain one returned Sample set as a project record Sample.

- 1) Submit a single Sample where assembly details, workmanship, fabrication techniques, connections, operation, and other similar characteristics are to be demonstrated.
 - 2) If variation in color, pattern, texture, or other characteristic is inherent in material or product represented by a Sample, submit at least three sets of paired units that show approximate limits of variations.
- D. Product Schedule: As required in individual Specification Sections, prepare a written summary indicating types of products required for the Work and their intended location. Include the following information in tabular form:
- E. Qualification Data: Prepare written information that demonstrates capabilities and experience of firm or person. Include lists of completed projects with project names and addresses, contact information of architects and owners, and other information specified.
- F. Design Data: Prepare and submit written and graphic information indicating compliance with indicated performance and design criteria in individual Specification Sections. Include list of assumptions and summary of loads. Include load diagrams if applicable. Provide name and version of software, if any, used for calculations. Number each page of submittal.
- G. Certificates:
1. Certificates and Certifications Submittals: Submit a statement that includes signature of entity responsible for preparing certification. Certificates and certifications shall be signed by an officer or other individual authorized to sign documents on behalf of that entity. Provide a notarized signature where indicated.
 2. Installer Certificates: Submit written statements on manufacturer's letterhead certifying that Installer complies with requirements in the Contract Documents and, where required, is authorized by manufacturer for this specific Project.
 3. Manufacturer Certificates: Submit written statements on manufacturer's letterhead certifying that manufacturer complies with requirements in the Contract Documents. Include evidence of manufacturing experience where required.
 4. Material Certificates: Submit written statements on manufacturer's letterhead certifying that material complies with requirements in the Contract Documents.
 5. Product Certificates: Submit written statements on manufacturer's letterhead certifying that product complies with requirements in the Contract Documents.
 6. Welding Certificates: Prepare written certification that welding procedures and personnel comply with requirements in the Contract Documents. Submit record of Welding Procedure Specification and Procedure Qualification Record on AWS forms. Include names of firms and personnel certified.
- H. Test and Research Reports:
1. Compatibility Test Reports: Submit reports written by a qualified testing agency, on testing agency's standard form, indicating and interpreting results of compatibility tests performed before installation of product. Include written recommendations for substrate preparation and primers required.
 2. Field Test Reports: Submit written reports indicating and interpreting results of field tests performed either during installation of product or after product is installed in its final location, for compliance with requirements in the Contract Documents.

3. Material Test Reports: Submit reports written by a qualified testing agency, on testing agency's standard form, indicating and interpreting test results of material for compliance with requirements in the Contract Documents.
4. Preconstruction Test Reports: Submit reports written by a qualified testing agency, on testing agency's standard form, indicating and interpreting results of tests performed before installation of product, for compliance with performance requirements in the Contract Documents.
5. Product Test Reports: Submit written reports indicating that current product produced by manufacturer complies with requirements in the Contract Documents. Base reports on evaluation of tests performed by manufacturer and witnessed by a qualified testing agency, or on comprehensive tests performed by a qualified testing agency.
6. Research Reports: Submit written evidence, from a model code organization acceptable to authorities having jurisdiction, that product complies with building code in effect for Project. Include the following information:
 - a. Name of evaluation organization.
 - b. Date of evaluation.
 - c. Time period when report is in effect.
 - d. Product and manufacturers' names.
 - e. Description of product.
 - f. Test procedures and results.
 - g. Limitations of use.

1.7 DELEGATED DESIGN SERVICES

- A. Performance and Design Criteria: Where professional design services or certifications by a design professional are specifically required of Contractor by the Contract Documents, provide products and systems complying with specific performance and design criteria indicated.
 1. If criteria indicated are insufficient to perform services or certification required, submit a written request for additional information to Architect.
- B. Delegated Design Services Certification: In addition to shop drawings, product data, and other required submissions, submit a certified PDF file digitally signed by the licensed design professional responsible in PR, for each product and system specifically assigned to the contractor to be designed or certified by a design professional.
 1. Indicate that products and systems comply with performance and design criteria in the Contract Documents. Include list of codes, loads, and other factors used in performing these services.

1.8 CONTRACTOR'S REVIEW

- A. Action Submittals and Informational Submittals: Review each submittal and check for coordination with other Work of the Contract and for compliance with the Contract Documents. Note corrections and field dimensions. Mark with approval stamp before submitting to Architect and Construction Manager.

- B. Contractor's Approval: Indicate Contractor's approval for each submittal with indication in web-based Project management software. Include name of reviewer, date of Contractor's approval, and statement certifying that submittal has been reviewed, checked, and approved for compliance with the Contract Documents.
 - 1. Architect will not review submittals received from Contractor that do not have Contractor's review and approval.

1.9 ARCHITECT'S REVIEW

- A. Action Submittals: Architect will review each submittal, indicate corrections or revisions required, and return it.
 - 1. PDF Submittals: Architect will indicate, via markup on each submittal, the appropriate action.
 - 2. Submittals by Web-Based Project Management Software: Architect will indicate, on Project management software website, the appropriate action.
- B. Informational Submittals: Architect will review each submittal and will not return it, or will return it if it does not comply with requirements. Architect will forward each submittal to appropriate party.
- C. Partial submittals prepared for a portion of the Work will be reviewed when use of partial submittals has received prior approval from Architect.
- D. Incomplete submittals are unacceptable, will be considered nonresponsive, and will be returned for resubmittal without review.
- E. Architect will return without review submittals received from sources other than Contractor.
- F. Submittals not required by the Contract Documents will be returned by Architect without action.

PART 2 - PRODUCTS (Not Used)

PART 3 - EXECUTION (Not Used)

END OF SECTION 013300

SECTION 014000 - QUALITY REQUIREMENTS

PART 1 - GENERAL

1.1 SUMMARY

- A. Section includes administrative and procedural requirements for quality assurance and quality control.
- B. Testing and inspection services are required to verify compliance with requirements specified or indicated. These services do not relieve Contractor of responsibility for compliance with the Contract Document requirements.
 - 1. Specified tests, inspections, and related actions do not limit Contractor's other quality-assurance and quality-control procedures that facilitate compliance with the Contract Document requirements.
 - 2. Requirements for Contractor to provide quality-assurance and quality-control services required by Architect, Owner, Commissioning Authority, Construction Manager, or authorities having jurisdiction are not limited by provisions of this Section.

1.2 DEFINITIONS

- A. Experienced: When used with an entity or individual, "experienced" unless otherwise further described means having successfully completed a minimum of **<Insert number>** previous projects similar in nature, size, and extent to this Project; being familiar with special requirements indicated; and having complied with requirements of authorities having jurisdiction.
- B. Field Quality-Control Tests and Inspections: Tests and inspections that are performed on-site for installation of the Work and for completed Work.
- C. Installer/Applicator/Erector: Contractor or another entity engaged by Contractor as an employee, Subcontractor, or Sub-subcontractor, to perform a particular construction operation, including installation, erection, application, assembly, and similar operations.
 - 1. Use of trade-specific terminology in referring to a Work result does not require that certain construction activities specified apply exclusively to specific trade(s).
- D. Mockups: Physical assemblies of portions of the Work constructed to establish the standard by which the Work will be judged. Mockups are not Samples.
 - 1. Mockups are used for one or more of the following:
 - a. Verify selections made under Sample submittals.
 - b. Demonstrate aesthetic effects.
 - c. Demonstrate the qualities of products and workmanship.
 - d. Demonstrate successful installation of interfaces between components and systems.

- e. Perform preconstruction testing to determine system performance.
 - 2. Product Mockups: Mockups that may include multiple products, materials, or systems specified in a single Section.
 - 3. In-Place Mockups: Mockups constructed on-site in their actual final location as part of permanent construction.
- E. Preconstruction Testing: Tests and inspections performed specifically for Project before products and materials are incorporated into the Work, to verify performance or compliance with specified criteria. Unless otherwise indicated, copies of reports of tests or inspections performed for other than the Project do not meet this definition.
- F. Product Tests: Tests and inspections that are performed by a nationally recognized testing laboratory (NRTL) in accordance with 29 CFR 1910.7, by a testing agency accredited in accordance with NIST's National Voluntary Laboratory Accreditation Program (NVLAP), or by a testing agency qualified to conduct product testing and acceptable to authorities having jurisdiction, to establish product performance and compliance with specified requirements.
- G. Source Quality-Control Tests and Inspections: Tests and inspections that are performed at the source; for example, plant, mill, factory, or shop.
- H. Testing Agency: An entity engaged to perform specific tests, inspections, or both. The term "testing laboratory" has the same meaning as the term "testing agency."
- I. Quality-Assurance Services: Activities, actions, and procedures performed before and during execution of the Work to guard against defects and deficiencies and substantiate that proposed construction will comply with requirements.
- J. Quality-Control Services: Tests, inspections, procedures, and related actions during and after execution of the Work to evaluate that actual products incorporated into the Work and completed construction comply with requirements. Contractor's quality-control services do not include contract administration activities performed by Architect.
- 1.3 DELEGATED DESIGN SERVICES
- A. Performance and Design Criteria: Where professional design services or certifications by a design professional are specifically required of Contractor by the Contract Documents, provide products and systems complying with specific performance and design criteria indicated.
- 1. If criteria indicated are not sufficient to perform services or certification required, submit a written request for additional information to Architect.
- B. Delegated Design Services Statement: Submit a statement, signed and sealed by the responsible design professional licensed in PR, for each product and system specifically assigned to Contractor to be designed or certified by a design professional, indicating that the products and systems are in compliance with performance and design criteria indicated. Include list of codes, loads, and other factors used in performing these services.

1.4 CONFLICTING REQUIREMENTS

- A. **Conflicting Standards and Other Requirements:** If compliance with two or more standards or requirements is specified and the standards or requirements establish different or conflicting requirements for minimum quantities or quality levels, inform the Architect regarding the conflict and obtain clarification prior to proceeding with the Work. Refer conflicting requirements that are different, but apparently equal, to Architect for clarification before proceeding.
- B. **Minimum Quantity or Quality Levels:** The quantity or quality level shown or specified is the minimum provided or performed. The actual installation may comply exactly with the minimum quantity or quality specified, or it may exceed the minimum within reasonable limits. To comply with these requirements, indicated numeric values are minimum or maximum, as appropriate, for the context of requirements. Refer uncertainties to Architect for a decision before proceeding.

1.5 ACTION SUBMITTALS

- A. **Mockup Shop Drawings:**
 - 1. Include plans, sections, elevations, and details, indicating materials and size of mockup construction.
 - 2. Indicate manufacturer and model number of individual components.
 - 3. Provide axonometric drawings for conditions difficult to illustrate in two dimensions.

1.6 INFORMATIONAL SUBMITTALS

- A. **Contractor's Statement of Responsibility:** When required by authorities having jurisdiction, submit copy of written statement of responsibility submitted to authorities having jurisdiction before starting work on the following systems:
 - 1. Seismic-force-resisting system, designated seismic system, or component listed in the Statement of Special Inspections.
 - 2. Main wind-force-resisting system or a wind-resisting component listed in the Statement of Special Inspections.
- B. **Testing Agency Qualifications:** For testing agencies specified in "Quality Assurance" Article to demonstrate their capabilities and experience. Include proof of qualifications in the form of a recent report on the inspection of the testing agency by a recognized authority.
- C. **Permits, Licenses, and Certificates:** For Owner's record, submit copies of permits, licenses, certifications, inspection reports, releases, jurisdictional settlements, notices, receipts for fee payments, judgments, correspondence, records, and similar documents established for compliance with standards and regulations bearing on performance of the Work.

1.7 REPORTS AND DOCUMENTS

- A. Test and Inspection Reports: Prepare and submit certified written reports specified in other Sections. Include the following:
1. Date of issue.
 2. Project title and number.
 3. Name, address, telephone number, and email address of testing agency.
 4. Dates and locations of samples and tests or inspections.
 5. Names of individuals making tests and inspections.
 6. Description of the Work and test and inspection method.
 7. Identification of product and Specification Section.
 8. Complete test or inspection data.
 9. Test and inspection results and an interpretation of test results.
 10. Record of temperature and weather conditions at time of sample taking and testing and inspection.
 11. Comments or professional opinion on whether tested or inspected Work complies with the Contract Document requirements.
 12. Name and signature of laboratory inspector.
 13. Recommendations on retesting and reinspecting.
- B. Manufacturer's Technical Representative's Field Reports: Prepare written information documenting manufacturer's technical representative's tests and inspections specified in other Sections. Include the following:
1. Statement on condition of substrates and their acceptability for installation of product.
 2. Statement that products at Project site comply with requirements.
 3. Summary of installation procedures being followed, whether they comply with requirements and, if not, what corrective action was taken.
 4. Results of operational and other tests and a statement of whether observed performance complies with requirements.
 5. Other required items indicated in individual Specification Sections.
- C. Factory-Authorized Service Representative's Reports: Prepare written information documenting manufacturer's factory-authorized service representative's tests and inspections specified in other Sections. Include the following:
1. Statement that equipment complies with requirements.
 2. Results of operational and other tests and a statement of whether observed performance complies with requirements.
 3. Other required items indicated in individual Specification Sections.

1.8 QUALITY ASSURANCE

- A. Qualifications paragraphs in this article establish the minimum qualification levels required; individual Specification Sections specify additional requirements.
- B. Manufacturer Qualifications: A firm experienced in manufacturing products or systems similar to those indicated for this Project and with a record of successful in-service performance, as well as sufficient production capacity to produce required units. As applicable, procure products

from manufacturers able to meet qualification requirements, warranty requirements, and technical or factory-authorized service representative requirements.

- C. Fabricator Qualifications: A firm experienced in producing products similar to those indicated for this Project and with a record of successful in-service performance, as well as sufficient production capacity to produce required units.
- D. Installer Qualifications: A firm or individual experienced in installing, erecting, applying, or assembling work similar in material, design, and extent to that indicated for this Project, whose work has resulted in construction with a record of successful in-service performance.
- E. Professional Engineer Qualifications: A professional engineer who is legally qualified to practice in jurisdiction where Project is located and who is experienced in providing engineering services of the kind indicated. Engineering services are defined as those performed for installations of the system, assembly, or product that are similar in material, design, and extent to those indicated for this Project.
- F. Specialists: Certain Specification Sections require that specific construction activities be performed by entities who are recognized experts in those operations. Specialists will satisfy qualification requirements indicated and engage in the activities indicated.
 - 1. Requirements of authorities having jurisdiction supersede requirements for specialists.
- G. Testing and Inspecting Agency Qualifications: An NRTL, an NVLAP, or an independent agency with the experience and capability to conduct testing and inspection indicated, as documented in accordance with ASTM E329; and with additional qualifications specified in individual Sections; and, where required by authorities having jurisdiction, that is acceptable to authorities.
- H. Manufacturer's Technical Representative Qualifications: An authorized representative of manufacturer who is trained and approved by manufacturer to observe and inspect installation of manufacturer's products that are similar in material, design, and extent to those indicated for this Project.
- I. Factory-Authorized Service Representative Qualifications: An authorized representative of manufacturer who is trained and approved by manufacturer to inspect, demonstrate, repair, and perform service on installations of manufacturer's products that are similar in material, design, and extent to those indicated for this Project.
- J. Preconstruction Testing: Where testing agency is indicated to perform preconstruction testing for compliance with specified requirements for performance and test methods, comply with the following:
 - 1. Contractor Responsibilities:
 - a. Provide test specimens representative of proposed products and construction.
 - b. Submit specimens in a timely manner with sufficient time for testing and analyzing results to prevent delaying the Work.
 - c. When testing is complete, remove test specimens and test assemblies; do not reuse products on Project.

2. Testing Agency Responsibilities: Submit a certified written report of each test, inspection, and similar quality-assurance service to Architect, through Construction Manager, with copy to Contractor. Interpret tests and inspections and state in each report whether tested and inspected work complies with or deviates from the Contract Documents.
- K. Mockups: Before installing portions of the Work requiring mockups, build mockups for each form of construction and finish required to comply with the following requirements, using materials indicated for the completed Work:
1. Build mockups of size indicated.
 2. Build mockups in location indicated or, if not indicated, as directed by Architect or Construction Manager.
 3. Notify Architect and Construction Manager seven days in advance of dates and times when mockups will be constructed.
 4. Employ supervisory personnel who will oversee mockup construction. Employ workers that will be employed to perform same tasks during the construction at Project.
 5. Demonstrate the proposed range of aesthetic effects and workmanship.
 6. Obtain Architect's approval of mockups before starting corresponding work, fabrication, or construction.
 - a. Allow seven days for initial review and each re-review of each mockup.
 7. Promptly correct unsatisfactory conditions noted by Architect's preliminary review, to the satisfaction of the Architect, before completion of final mockup.
 8. Approval of mockups by the Architect does not constitute approval of deviations from the Contract Documents contained in mockups unless Architect specifically approves such deviations in writing.
 9. Maintain mockups during construction in an undisturbed condition as a standard for judging the completed Work.
 10. Demolish and remove mockups when directed unless otherwise indicated.

1.9 QUALITY CONTROL

- A. Owner Responsibilities: Where quality-control services are indicated as Owner's responsibility, Owner will engage a qualified testing agency to perform these services.
1. Owner will furnish Contractor with names, addresses, and telephone numbers of testing agencies engaged and a description of types of testing and inspection they are engaged to perform.
 2. Costs for retesting and reinspecting construction that replaces or is necessitated by Work that failed to comply with the Contract Documents will be charged to Contractor.
- B. Contractor Responsibilities: Tests and inspections not explicitly assigned to Owner are Contractor's responsibility. Perform additional quality-control activities, whether specified or not, to verify and document that the Work complies with requirements.
1. Engage a qualified testing agency to perform quality-control services.

- a. Contractor will not employ same entity engaged by Owner, unless agreed to in writing by Owner.
 2. Notify testing agencies at least 24 hours in advance of time when Work that requires testing or inspection will be performed.
 3. Where quality-control services are indicated as Contractor's responsibility, submit a certified written report, in duplicate, of each quality-control service.
 4. Testing and inspection requested by Contractor and not required by the Contract Documents are Contractor's responsibility.
 5. Submit additional copies of each written report directly to authorities having jurisdiction, when they so direct.
- C. Retesting/Reinspecting: Regardless of whether original tests or inspections were Contractor's responsibility, provide quality-control services, including retesting and reinspecting, for construction that replaced Work that failed to comply with the Contract Documents.
- D. Testing Agency Responsibilities: Cooperate with Architect, Construction Manager, and Contractor in performance of duties. Provide qualified personnel to perform required tests and inspections.
1. Notify Architect, Construction Manager, and Contractor promptly of irregularities or deficiencies observed in the Work during performance of its services.
 2. Determine the locations from which test samples will be taken and in which in-situ tests are conducted.
 3. Conduct and interpret tests and inspections and state in each report whether tested and inspected Work complies with or deviates from requirements.
 4. Submit a certified written report, in duplicate, of each test, inspection, and similar quality-control service through Contractor.
 5. Do not release, revoke, alter, or increase the Contract Document requirements or approve or accept any portion of the Work.
 6. Do not perform duties of Contractor.
- E. Manufacturer's Field Services: Where indicated, engage a factory-authorized service representative to inspect field-assembled components and equipment installation, including service connections. Report results in writing as specified in Section 013300 "Submittal Procedures."
- F. Manufacturer's Technical Services: Where indicated, engage a manufacturer's technical representative to observe and inspect the Work. Manufacturer's technical representative's services include participation in preinstallation conferences, examination of substrates and conditions, verification of materials, observation of Installer activities, inspection of completed portions of the Work, and submittal of written reports.
- G. Contractor's Associated Requirements and Services: Cooperate with agencies and representatives performing required tests, inspections, and similar quality-control services, and provide reasonable auxiliary services as requested. Notify agency sufficiently in advance of operations to permit assignment of personnel. Provide the following:
1. Access to the Work.
 2. Incidental labor and facilities necessary to facilitate tests and inspections.

3. Adequate quantities of representative samples of materials that require testing and inspection. Assist agency in obtaining samples.
4. Facilities for storage and field curing of test samples.
5. Preliminary design mix proposed for use for material mixes that require control by testing agency.
6. Security and protection for samples and for testing and inspection equipment at Project site.

H. Coordination: Coordinate sequence of activities to accommodate required quality-assurance and quality-control services with a minimum of delay and to avoid necessity of removing and replacing construction to accommodate testing and inspection.

1. Schedule times for tests, inspections, obtaining samples, and similar activities.

1.10 SPECIAL TESTS AND INSPECTIONS

A. Special Tests and Inspections: Owner will engage a qualified special inspector to conduct special tests and inspections required by authorities having jurisdiction as the responsibility of Owner, and as follows:

1. Verifying that manufacturer maintains detailed fabrication and quality-control procedures and reviewing the completeness and adequacy of those procedures to perform the Work.
2. Notifying Architect, Construction Manager, and Contractor promptly of irregularities and deficiencies observed in the Work during performance of its services.
3. Submitting a certified written report of each test, inspection, and similar quality-control service to Architect, through Construction Manager, with copy to Contractor and to authorities having jurisdiction.
4. Submitting a final report of special tests and inspections at Substantial Completion, which includes a list of unresolved deficiencies.
5. Interpreting tests and inspections and stating in each report whether tested and inspected work complies with or deviates from the Contract Documents.
6. Retesting and reinspecting corrected Work.
7. .

PART 2 - PRODUCTS (Not Used)

PART 3 - EXECUTION

3.1 TEST AND INSPECTION LOG

A. Test and Inspection Log: Prepare a record of tests and inspections. Include the following:

1. Date test or inspection was conducted.
2. Description of the Work tested or inspected.
3. Date test or inspection results were transmitted to Architect.
4. Identification of testing agency or special inspector conducting test or inspection.

- B. Maintain log at Project site. Post changes and revisions as they occur. Provide access to test and inspection log for Architect's and Construction Manager's reference during normal working hours.
 - 1. Submit log at Project closeout as part of Project Record Documents.

3.2 REPAIR AND PROTECTION

- A. General: On completion of testing, inspection, sample taking, and similar services, repair damaged construction and restore substrates and finishes.
 - 1. Provide materials and comply with installation requirements specified in other Specification Sections or matching existing substrates and finishes. Restore patched areas and extend restoration into adjoining areas with durable seams that are as invisible as possible. Comply with the Contract Document requirements for cutting and patching in Section 017300 "Execution."
- B. Protect construction exposed by or for quality-control service activities.
- C. Repair and protection are Contractor's responsibility, regardless of the assignment of responsibility for quality-control services.

END OF SECTION 014000

SECTION 015000 - TEMPORARY FACILITIES AND CONTROLS

PART 1 - GENERAL

1.1 SUMMARY

- A. Section includes requirements for temporary utilities, support facilities, and security and protection facilities.
- B. Related Requirements:
 - 1. Section 011000 "Summary" for work restrictions and limitations on utility interruptions.

1.2 USE CHARGES

- A. Installation, removal, and use charges for temporary facilities to be included in the Contract Sum unless otherwise indicated. Allow other entities engaged in the Project to use temporary services and facilities without cost, including, but not limited to, Owner's construction forces, Architect, testing agencies, and authorities having jurisdiction.
- B. Water and Sewer Service from Existing System: Water from Owner's existing water system is available for use with metering. Provide connections and extensions of services and metering as required for construction operations.
- C. Electric Power Service from Existing System: Electric power from Owner's existing system is available for use with metering. Provide connections and extensions of services and metering as required for construction operations.

1.3 INFORMATIONAL SUBMITTALS

- A. Site Utilization Plan: Show temporary facilities, temporary utility lines and connections, staging areas, construction site entrances, vehicle circulation, and parking areas for construction personnel.
- A. Project Identification and Temporary Signs: Show fabrication and installation details, including plans, elevations, details, layouts, typestyles, graphic elements, and message content.
- B. Fire-Safety Program: Show compliance with requirements of NFPA 241 and authorities having jurisdiction. Indicate Contractor personnel responsible for management of fire-prevention program.
- C. Moisture- and Mold-Protection Plan: Describe procedures and controls for protecting materials and construction from water absorption and damage and mold. Describe delivery, handling, storage, installation, and protection provisions for materials subject to water absorption or water damage.

1. Indicate procedures for discarding water-damaged materials, protocols for mitigating water intrusion into completed Work, and requirements for replacing water-damaged Work.
2. Indicate sequencing of work that requires water, such as sprayed fire-resistive materials, plastering, and terrazzo grinding, and describe plans for dealing with water from these operations. Show procedures for verifying that wet construction has dried sufficiently to permit installation of finish materials.
3. Indicate methods to be used to avoid trapping water in finished work.

1.4 QUALITY ASSURANCE

- A. Electric Service: Comply with NECA, NEMA, and UL standards and regulations for temporary electric service. Install service to comply with NFPA 70.
- B. Tests and Inspections: Arrange for authorities having jurisdiction to test and inspect each temporary utility before use. Obtain required certifications and permits.
- C. Accessible Temporary Egress: Comply with applicable provisions in the DOJ's 2010 ADA Standards for Accessible Design and ICC A117.1.

1.5 PROJECT CONDITIONS

- A. Temporary Use of Permanent Facilities: Engage Installer of each permanent service to assume responsibility for operation, maintenance, and protection of each permanent service during its use as a construction facility before Owner's acceptance, regardless of previously assigned responsibilities.

PART 2 - PRODUCTS

2.1 TEMPORARY FACILITIES

- A. Field Offices: Prefabricated or mobile units with serviceable finishes, temperature controls, and foundations adequate for normal loading.
- B. Common-Use Field Office: Of sufficient size to accommodate needs of Owner, Architect, Construction Manager, and construction personnel office activities and to accommodate Project meetings. Keep office clean and orderly. Furnish and equip offices

2.2 EQUIPMENT

- A. Fire Extinguishers: Portable, UL rated; with class and extinguishing agent as required by locations and classes of fire exposures.
- B. HVAC Equipment: Unless Owner authorizes use of permanent HVAC system, provide vented, self-contained, liquid-propane-gas or fuel-oil heaters with individual space thermostatic control.
 1. Heating, Cooling, and Dehumidifying Units: Listed and labeled for type of fuel being consumed, by a qualified testing agency acceptable to authorities having jurisdiction, and marked for intended location and application.

2. Permanent HVAC System: If Owner authorizes use of permanent HVAC system for temporary use during construction, provide filter with MERV of 8 at each return-air grille in system and remove at end of construction. and clean HVAC system.
- C. Air-Filtration Units: Primary and secondary HEPA-filter-equipped portable units with four-stage filtration. Provide single switch for emergency shutoff. Configure to run continuously.

PART 3 - EXECUTION

3.1 TEMPORARY FACILITIES, GENERAL

- A. Conservation: Coordinate construction and use of temporary facilities with consideration given to conservation of energy, water, and materials. Coordinate use of temporary utilities to minimize waste.
1. Salvage materials and equipment involved in performance of, but not actually incorporated into, the Work. See other Sections for disposition of salvaged materials that are designated as Owner's property.

3.2 INSTALLATION, GENERAL

- A. Locate facilities where they will serve Project adequately and result in minimum interference with performance of the Work. Relocate and modify facilities as required by progress of the Work.
- B. Provide each facility ready for use when needed to avoid delay. Do not remove until facilities are no longer needed or are replaced by authorized use of completed permanent facilities.
- C. Isolation of Work Areas in Occupied Facilities: Prevent dust, fumes, and odors from entering occupied areas.

3.3 TEMPORARY UTILITY INSTALLATION

- A. General: Install temporary service or connect to existing service.
1. Arrange with utility company, Owner, and existing users for time when service can be interrupted, if necessary, to make connections for temporary services.
- B. Sewers and Drainage: Provide temporary utilities to remove effluent lawfully.
1. Connect temporary sewers to municipal system private system indicated as directed by authorities having jurisdiction.
- C. Water Service: Install water service and distribution piping in sizes and pressures adequate for construction.
- D. Sanitary Facilities: Provide temporary toilets, wash facilities, safety shower and eyewash facilities, and drinking water for use of construction personnel. Comply with requirements of

authorities having jurisdiction for type, number, location, operation, and maintenance of fixtures and facilities.

- E. Temporary Heating and Cooling: Provide temporary heating and cooling required by construction activities for curing or drying of completed installations or for protecting installed construction from adverse effects of low temperatures or high humidity. Select equipment that will not have a harmful effect on completed installations or elements being installed.
 - 1. Provide temporary dehumidification systems when required to reduce ambient and substrate moisture levels to level required to allow installation or application of finishes and their proper curing or drying.
- F. Electric Power Service: Provide electric power service and distribution system of sufficient size, capacity, and power characteristics required for construction operations.
 - 1. Install electric power service overhead unless otherwise indicated.
- G. Lighting: Provide temporary lighting with local switching that provides adequate illumination for construction operations, observations, inspections, and traffic conditions.
 - 1. Install and operate temporary lighting that fulfills security and protection requirements without operating entire system.
- H. Telephone Service: Provide temporary telephone service in common-use facilities for use by all construction personnel. Install WiFi cell phone access equipment and one land-based telephone line(s) for each field office.
- I. Electronic Communication Service: Provide secure WiFi wireless connection to internet with provisions for access by Architect and Owner.
 - 1. Printer: "All-in-one" unit equipped with printer server, combining color printing, photocopying, scanning, and faxing, or separate units for each of these three functions.
 - 2. Internet Service: Broadband modem, router, and ISP, equipped with hardware firewall, providing minimum 10.0 -Mbps upload and 15 -Mbps download speeds at each computer.
 - 3. Internet Security: Integrated software, providing software firewall, virus, spyware, phishing, and spam protection in a combined application.
 - 4. Backup: External hard drive, minimum 2 terrabytes, with automated backup software providing daily backups.

3.4 SUPPORT FACILITIES INSTALLATION

- A. Comply with the following:
 - 1. Provide construction for temporary field offices, shops, and sheds located within construction area or within 30 feet (9 m) of building lines that is noncombustible in accordance with ASTM E136. Comply with NFPA 241.
- B. Traffic Controls: Comply with requirements of authorities having jurisdiction.
 - 1. Protect existing site improvements to remain including curbs, pavement, and utilities.

2. Maintain access for fire-fighting equipment and access to fire hydrants.
- C. Parking: Provide temporary offsite parking areas for construction personnel.
- D. Storage and Staging: Provide temporary offsite area for storage and staging needs.
- E. Dewatering Facilities and Drains: Comply with requirements of authorities having jurisdiction. Maintain Project site, excavations, and construction free of water.
1. Dispose of rainwater in a lawful manner that will not result in flooding Project or adjoining properties or endanger permanent Work or temporary facilities.
- F. Project Signs: Provide Project signs as indicated. Unauthorized signs are not permitted.
1. Identification Signs: Provide Project identification signs as indicated on the section 1.3 INFORMATIVE SUBMISSIONS / B - Project Identification and Temporary Signs.
 2. Temporary Signs: Provide other signs as indicated and as required to inform public and individuals seeking entrance to Project.
 - a. Provide temporary, directional signs for construction personnel and visitors.
 3. Maintain and touch up signs so they are always legible.
 4. The Bidder shall, prior to the submission of its proposal, consider and familiarize itself with all the laws and regulations applicable to the development and financing of the work (design and construction) and all those that may affect the cost, progress, development, and performance of the work (design and construction).
 5. The Bidder who wishes to participate in this application must bid on all the established items on the price sheet, failure to bid on any of the items will be sufficient cause for disqualification.
 6. Electrical Work Certification is required for all electrical work performed as part of the development of the work.
 7. Plumbing Job Certification is required for all plumbing work, performed as part of the development of the work.
 8. The Contractor shall implement all security measures deemed necessary to delimit and label the areas impacted by the works related to this project, as well as the areas provided for the storage of materials and equipment, in such a way that access to them by persons outside the works included in the contract may be restricted. during the development of the work.
 9. The emission of noise from the areas impacted by the works included in the contract does not exceed the maximum levels established by law and in accordance with the provisions set forth in applicable regulations.
 10. The Contractor shall take all necessary measures to avoid:
 11. The spread of fugitive dust from removal or demolition activities and hauling of materials or debris, in strict compliance with the provisions established by law and in applicable regulations.
 12. The use of materials and equipment that emit toxic gases and waste into the environment, in strict compliance with the provisions established by law and applicable regulations.
 13. The Contractor shall be responsible for ensuring that all subcontracted work is performed in a timely manner, and in compliance with applicable federal and state regulations, policies.

14. The Bidder acknowledges and agrees that all parties will attend a pre-construction meeting that shall be conducted prior to the commencement of construction and prior to the issuance of the Notice to Proceed.
15. The Bidder acknowledges and agrees that all parties will attend the progress meetings of the construction activities to be carried out on a weekly basis.
16. The Contractor shall install, as part of the work included in the contract and at the location established by the designated representative of the Petitioning Entity, an identification signs on washable material. This work will consist of the installation, assembly, maintenance, and removal of the 16' x 8' project identification signs, in accordance with these specifications and in accordance with the design and dimensions indicated in the Labelling Manual, as well as the locations shown on drawings or determined by the Project Engineer or representative of the Petitioning Entity.
17. Each sign and support structure will be constructed with good quality new wood from the following way:
18. Frame: it will be made of dry wood of grade No. 1, solid, square, coated on all four sides, no loose knots or decay. It can be Douglas fir, spruce, oak, or cypress in accordance with AASHTO M 168. The wood should be pressure treated with pentachlorophenol or chromate copper arsenate in accordance with the standards of the American Association of Wood Conservators (AWPA).
19. Sign Panel: Shall be 1/2" thick exterior type, high density, resin-bound, grade B-B or better according to the PS-1 specification of the National Bureau of Standards for Plywood. It will be laminated with vinyl or aluminum on both sides.
20. Full-color UV-curable digital printing process, with a minimum resolution of 720 DPI. Printing will be guaranteed for a minimum of three (3) years.
21. Hardware: the bolts, nuts, washers, and hardware to erect the whole of the sign must be made of aluminum or galvanized steel.
22. Sign Construction Requirements:
23. The Contractor shall supply and affix the number of signs indicated in the Contract documents. If this is not indicated, the Petitioning Entity will determine the number of signs to be installed.
24. The Contractor shall install the signs in such a manner as not to obstruct the visibility of the traffic signs.
25. The Contractor shall maintain the signs in good condition throughout the period repainting and repairing them as needed.
26. After the construction work has been completed by the Contractor and accepted per Requesting Entity, the Contractor shall remove the signs from the project site, unless that the Petitioning Entity indicates otherwise in writing.
27. Measurement Method:
28. Project identification signs will be measured by the number of units furnished, erected, and installed individually.
29. Maintenance, repainting, and repair of signs throughout the construction and removal of these after the construction work is completed, they will not be metered for payment, but will be a subsidiary obligation under this specification.
30. The Bidder shall be responsible for arranging its own transportation to the visual inspection.
31. The Bidder acknowledges and agrees that it will faithfully comply with the provisions of Law No. 146 of August 10, 1995, as amended.
32. Contractor understands that all federal provisions set forth in 2 CFR 200.101 are applicable to this bidding process.
33. For the employee's interview history, the Contractor will use HUD Form 11.

34. It shall be the responsibility of the Contractor to provide and install a sign as part of the Davis Bacon program requirement and related laws.
35. It shall be the responsibility of the Contractor to supply, complete and deliver the payrolls for the wages of its employees and subcontractor, using the format (WH347).
36. The contractor is responsible for rectifying the measurements and assessing the existing conditions of each of PRIDCO's facilities, contemplated in the Scope of Work provided, prior to the Presentation of your offer.
37. As recipients of HUD financial assistance, PRDOH and its contractors and subcontractors who those working within the PRDOH CDBG-DR Program are subject to the requirements of the Davis Bacon Act of 1931 (DBA), 40 U.S.C. § 3141 et seq., which guarantees fair wages, benefits, and overtime to employees while working on construction, alteration, or repair projects funded by the government for more than \$2,000.00 The Davis Bacon and Related Laws (DBRA) determine the Davis Bacon's applicability to Federally assisted construction contracts. The Housing and Community Development Act of 1974 (HCD), 42 U.S.C. § 5301 et seq., Section 110 of the Act, determines the applicability of the DBRA to CDBG-DR. The DOL establishes the main set of regulations for labor rules in 29 CFR Parts 1-7, 29 CFR Part 1- Regulates the determination 29 CFR Part 3 – Copeland "Anti-kickback" Act of 1934, 18 U.S.C. § 874 and 40 U.S.C. § 3145, defines anti-kickback regulations; Weekly Payroll Obligation and Governs Deductions 29 CFR Part 5 - Defines Labor Standards Regulations, 29 CFR Part 6 - Regulates Labor Standards administrative procedures for enforcing labor standards, 29 CFR Part 7 - Regulates the noncompliance. All covered contracts must include Davis-Bacon and other standards clauses and applicable wage determinations.

G. Project Signs: Provide Project signs as indicated. Unauthorized signs are not permitted.

1. Identification Signs: Provide Project identification signs as indicated on Sign Details.
2. The Contractor shall install, as part of the work included in the contract and at the location established by the designated representative of the Owner, an identification sign in washable material. This work will consist of the installation, assembly, maintenance and removal of the 16' x 8' project identification signs, in accordance with these specifications.
3. Each sign and support structure shall be constructed from good quality new wood as follows:
 - a. Frame: It will be made of dry wood of grade No. 1, solid, squared, coated on all four sides, without loose knots or decay. It can be Douglas fir, spruce, oak, or cypress as stipulated in AASHTO M 168. Wood must be pressure treated with pentachlorophenol or chromate copper arsenate in accordance with American Wood Conservators Association (AWPA) standards.
 - b. Sign Panel: Shall be 1/2" thick, high-density plywood, resin-bound plywood, grade B-B or better per National Bureau of Standards specification PS-1 for plywood. It will be laminated with vinyl or aluminum on both sides.
 - c. Full-color UV curing digital printing process, with a minimum resolution of 720 DPI. Printing will be guaranteed for a minimum of three (3) years.
 - d. Hardware: The bolts, nuts, washers, and hardware to erect the sign assembly must be aluminum or galvanized steel.
4. Sign Construction Requirements
 - a. The Contractor shall supply and affix the number of signs indicated by the Owner representative.

- b. The Contractor shall install the signs in a manner that does not obstruct the visibility of traffic signs.
 - c. The Contractor shall maintain the signs in good condition throughout the construction period, repainting and repairing them as necessary.
 - d. After the construction work has been completed by the Contractor and accepted by the Owner, the Contractor shall remove the signs from the project site, unless otherwise indicated in writing by the Owner representative.
- 5. Temporary Signs: Provide other signs as required to inform public and individuals seeking entrance to Project.
 - a. Provide temporary, directional signs for construction personnel and visitors.
- 6. Maintain and touch up signs so they are legible at all times.
- H. Waste Disposal Facilities: Provide waste-collection containers in sizes adequate to handle waste from construction operations. Comply with requirements of authorities having jurisdiction.
- I. Lifts and Hoists: Provide facilities necessary for hoisting materials and personnel.
 - 1. Truck cranes and similar devices used for hoisting materials are considered "tools and equipment" and not temporary facilities.
- J. Temporary Stairs: Until permanent stairs are available, provide temporary stairs where ladders are not adequate.
- K. Existing Stair Usage: Use of Owner's existing stairs will be permitted, provided stairs are cleaned and maintained in a condition acceptable to Owner. At Substantial Completion, restore stairs to condition existing before initial use.
 - 1. Provide protective coverings, barriers, devices, signs, or other procedures to protect stairs and to maintain means of egress. If stairs become damaged, restore damaged areas so no evidence remains of correction work.
- L. Temporary Use of Permanent Stairs: Use of new stairs for construction traffic will be permitted, provided stairs are protected and finishes restored to new condition at time of Substantial Completion.

3.5 SECURITY AND PROTECTION FACILITIES INSTALLATION

- A. Protection of Existing Facilities: Protect existing vegetation, equipment, structures, utilities, and other improvements at Project site and on adjacent properties, except those indicated to be removed or altered. Repair damage to existing facilities.
 - 1. Where access to adjacent properties is required in order to affect protection of existing facilities, obtain written permission from adjacent property owner to access property for that purpose.
- B. Environmental Protection: Provide protection, operate temporary facilities, and conduct construction as required to comply with environmental regulations and that minimize possible air, waterway, and subsoil contamination or pollution or other undesirable effects.

- C. Temporary Erosion and Sedimentation Control: Comply with requirements of EPA Construction General Permit or authorities having jurisdiction, whichever is more stringent and requirements specified in Section 311000 "Site Clearing."
- D. Temporary Erosion and Sedimentation Control: Provide measures to prevent soil erosion and discharge of soil-bearing water runoff and airborne dust to undisturbed areas and to adjacent properties and walkways, in accordance with requirements of EPA Construction General Permit or authorities having jurisdiction, whichever is more stringent.
- E. Stormwater Control: Comply with requirements of authorities having jurisdiction. Provide barriers in and around excavations and subgrade construction to prevent flooding by runoff of stormwater from heavy rains.
- F. Tree and Plant Protection: Install temporary fencing located as indicated or outside the drip line of trees to protect vegetation from damage from construction operations. Protect tree root systems from damage, flooding, and erosion.
- G. Pest Control: Engage pest-control service to recommend practices to minimize attraction and harboring of rodents, roaches, and other pests and to perform extermination and control procedures at regular intervals so Project will be free of pests and their residues at Substantial Completion. Perform control operations lawfully, using materials approved by authorities having jurisdiction.
- H. Site Enclosure Fence: Before construction operations begin, coordinate with Construction Manager the need to furnish and install site enclosure fence in a manner that will prevent people from easily entering site except by entrance gates.
- I. Barricades, Warning Signs, and Lights: Comply with requirements of authorities having jurisdiction for erecting structurally adequate barricades, including warning signs and lighting.
- J. Temporary Egress: Provide temporary egress from existing occupied facilities as indicated and as required by authorities having jurisdiction. Provide signage directing occupants to temporary egress.
- K. Temporary Enclosures: Provide temporary enclosures for protection of construction, in progress and completed, from exposure, foul weather, other construction operations, and similar activities. Provide temporary weathertight enclosure for building exterior.
 - 1. Where heating or cooling is needed and permanent enclosure is incomplete, insulate temporary enclosures.
- L. Temporary Fire Protection: Install and maintain temporary fire-protection facilities of types needed to protect against reasonably predictable and controllable fire losses. Comply with NFPA 241; manage fire-prevention program.
 - 1. Prohibit smoking in construction areas. Comply with additional limits on smoking specified in other Sections.
 - 2. Supervise welding operations, combustion-type temporary heating units, and similar sources of fire ignition in accordance with requirements of authorities having jurisdiction.

3. Develop and supervise an overall fire-prevention and -protection program for personnel at Project site. Review needs with local fire department and establish procedures to be followed. Instruct personnel in methods and procedures. Post warnings and information.
4. Provide temporary standpipes and hoses for fire protection. Hang hoses with a warning sign stating that hoses are for fire-protection purposes only and are not to be removed. Match hose size with outlet size and equip with suitable nozzles.

3.6 MOISTURE AND MOLD CONTROL

- A. Moisture and Mold Protection: Protect stored materials and installed Work in accordance with Moisture and Mold Protection Plan.
- B. Exposed Construction Period: Before installation of weather barriers, when materials are subject to wetting and exposure and to airborne mold spores, protect as follows:
 1. Protect porous materials from water damage.
 2. Protect stored and installed material from flowing or standing water.
 3. Keep porous and organic materials from coming into prolonged contact with concrete.
 4. Remove standing water from decks.
 5. Keep deck openings covered or dammed.
- C. Partially Enclosed Construction Period: After installation of weather barriers but before full enclosure and conditioning of building, when installed materials are still subject to infiltration of moisture and ambient mold spores, protect as follows:
 1. Do not load or install drywall or other porous materials or components, or items with high organic content, into partially enclosed building.
 2. Keep interior spaces reasonably clean and protected from water damage.
 3. Periodically collect and remove waste containing cellulose or other organic matter.
 4. Discard or replace water-damaged material.
 5. Do not install material that is wet.
 6. Discard and replace stored or installed material that begins to grow mold.
 7. Perform work in a sequence that allows wet materials adequate time to dry before enclosing the material in gypsum board or other interior finishes.
- D. Controlled Construction Period: After completing and sealing of the building enclosure but prior to the full operation of permanent HVAC systems, maintain as follows:
 1. Control moisture and humidity inside building by maintaining effective dry-in conditions.
 2. Use temporary or permanent HVAC system to control humidity within ranges specified for installed and stored materials.
 3. Comply with manufacturer's written instructions for temperature, relative humidity, and exposure to water limits.

3.7 OPERATION, TERMINATION, AND REMOVAL

- A. Supervision: Enforce strict discipline in use of temporary facilities. To minimize waste and abuse, limit availability of temporary facilities to essential and intended uses.

- B. Maintenance: Maintain facilities in good operating condition until removal.
 - 1. Maintain operation of temporary enclosures, heating, cooling, humidity control, ventilation, and similar facilities on a 24-hour basis where required to achieve indicated results and to avoid possibility of damage.
- C. Temporary Facility Changeover: Do not change over from using temporary security and protection facilities to permanent facilities until Substantial Completion.
- D. Termination and Removal: Remove each temporary facility when need for its service has ended, when it has been replaced by authorized use of a permanent facility, or no later than Substantial Completion. Complete or, if necessary, restore permanent construction that may have been delayed because of interference with temporary facility. Repair damaged Work, clean exposed surfaces, and replace construction that cannot be satisfactorily repaired.
 - 1. Materials and facilities that constitute temporary facilities are property of Contractor. Owner reserves right to take possession of Project identification signs.
 - 2. At Substantial Completion, repair, renovate, and clean permanent facilities used during construction period.

3.8 SIGN DETAILS



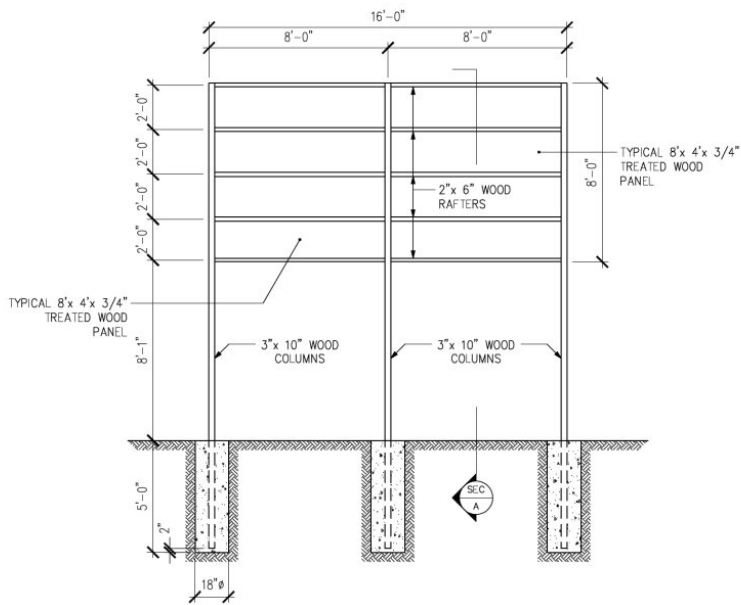

TEMPORARY SIGN ELEVATION (2)
 N.T.S. (C2-04)

- NOTES:
 1). CONCRETE STRENGTH $f_c = 3,000$ PSI
 2). ALL WOOD SECTION SHALL BE TREATED WOOD.
 3). THE SIGN SHALL BE VISIBLE FROM THE STREET.

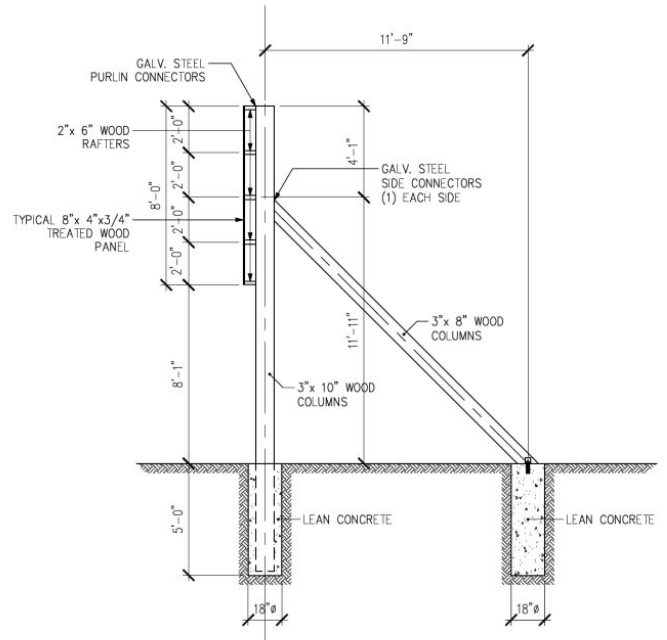

SECTION (SEC)
 N.T.S. (A)

END OF SECTION 015000

SECTION 024119 - SELECTIVE DEMOLITION

PART 1 - GENERAL

1.1 SUMMARY

A. Section Includes:

1. Demolition and removal of selected portions of building or structure.
2. Demolition and removal of selected site elements.
3. Salvage of existing items to be reused or recycled.

1.2 MATERIALS OWNERSHIP

- ##### A. Unless otherwise indicated, demolition waste becomes property of Contractor.
- ##### B. Historic items, relics, antiques, and similar objects including, but not limited to, cornerstones and their contents, commemorative plaques and tablets, and other items of interest or value to Owner that may be uncovered during demolition remain the property of Owner.
1. Carefully salvage in a manner to prevent damage and promptly return to Owner.

1.3 PREINSTALLATION MEETINGS

- ##### A. Predemolition Conference: Conduct conference at Project site.

1.4 INFORMATIONAL SUBMITTALS

- ##### A. Engineering Survey: Submit engineering survey of condition of building.
- ##### B. Proposed Protection Measures: Submit report, including Drawings, that indicates the measures proposed for protecting individuals and property, for environmental protection, for dust control and, for noise control. Indicate proposed locations and construction of barriers.
- ##### C. Schedule of selective demolition activities with starting and ending dates for each activity.
- ##### D. Predemolition photographs or video.
- ##### E. Statement of Refrigerant Recovery: Signed by refrigerant recovery technician.

1.5 CLOSEOUT SUBMITTALS

- ##### A. Inventory of items that have been removed and salvaged.

1.6 QUALITY ASSURANCE

- A. Refrigerant Recovery Technician Qualifications: Certified by an EPA-approved certification program.

1.7 FIELD CONDITIONS

- A. Owner will occupy portions of building immediately adjacent to selective demolition area. Conduct selective demolition so Owner's operations will not be disrupted.
- B. Conditions existing at time of inspection for bidding purpose will be maintained by Owner as far as practical.
- C. Notify Architect of discrepancies between existing conditions and Drawings before proceeding with selective demolition.
- D. Hazardous Materials: It is not expected that hazardous materials will be encountered in the Work.
 - 1. Hazardous materials will be removed by Owner before start of the Work.
 - 2. If suspected hazardous materials are encountered, do not disturb; immediately notify Architect and Owner. Hazardous materials will be removed by Owner under a separate contract.
- E. Storage or sale of removed items or materials on-site is not permitted.
- F. Utility Service: Maintain existing utilities indicated to remain in service and protect them against damage during selective demolition operations.
 - 1. Maintain fire-protection facilities in service during selective demolition operations.
- G. Arrange selective demolition schedule so as not to interfere with Owner's operations.

1.8 WARRANTY

- A. Existing Warranties: Remove, replace, patch, and repair materials and surfaces cut or damaged during selective demolition, by methods and with materials and using approved contractors so as not to void existing warranties.

PART 2 - PRODUCTS

2.1 PERFORMANCE REQUIREMENTS

- A. Regulatory Requirements: Comply with governing EPA notification regulations before beginning selective demolition. Comply with hauling and disposal regulations of authorities having jurisdiction.
- B. Standards: Comply with ANSI/ASSP A10.6 and NFPA 241.

PART 3 - EXECUTION

3.1 EXAMINATION

- A. Verify that utilities have been disconnected and capped before starting selective demolition operations.
- B. Perform an engineering survey of condition of building to determine whether removing any element might result in structural deficiency or unplanned collapse of any portion of structure or adjacent structures during selective building demolition operations.
- C. Inventory and record the condition of items to be removed and salvaged.

3.2 PREPARATION

- A. Refrigerant: Before starting demolition, remove refrigerant from mechanical equipment according to 40 CFR 82 and regulations of authorities having jurisdiction.

3.3 UTILITY SERVICES AND MECHANICAL/ELECTRICAL SYSTEMS

- A. Existing Services/Systems to Remain: Maintain services/systems indicated to remain and protect them against damage.
- B. Existing Services/Systems to Be Removed, Relocated, or Abandoned: Locate, identify, disconnect, and seal or cap off utility services and mechanical/electrical systems serving areas to be selectively demolished.
 - 1. Owner will arrange to shut off indicated services/systems when requested by Contractor.
 - 2. Arrange to shut off utilities with utility companies.
 - 3. If services/systems are required to be removed, relocated, or abandoned, provide temporary services/systems that bypass area of selective demolition and that maintain continuity of services/systems to other parts of building.
 - 4. Disconnect, demolish, and remove fire-suppression systems, plumbing, and HVAC systems, equipment, and components indicated on Drawings to be removed.
 - a. Piping to Be Removed: Remove portion of piping indicated to be removed and cap or plug remaining piping with same or compatible piping material.
 - b. Piping to Be Abandoned in Place: Drain piping and cap or plug piping with same or compatible piping material and leave in place.
 - c. Equipment to Be Removed: Disconnect and cap services and remove equipment.
 - d. Equipment to Be Removed and Reinstalled: Disconnect and cap services and remove, clean, and store equipment; when appropriate, reinstall, reconnect, and make equipment operational.
 - e. Equipment to Be Removed and Salvaged: Disconnect and cap services and remove equipment and deliver to Owner.
 - f. Ducts to Be Removed: Remove portion of ducts indicated to be removed and plug remaining ducts with same or compatible ductwork material.

- g. Ducts to Be Abandoned in Place: Cap or plug ducts with same or compatible ductwork material and leave in place.

3.4 PROTECTION

- A. Temporary Protection: Provide temporary barricades and other protection required to prevent injury to people and damage to adjacent buildings and facilities to remain.
- B. Temporary Shoring: Design, provide, and maintain shoring, bracing, and structural supports as required to preserve stability and prevent movement, settlement, or collapse of construction and finishes to remain, and to prevent unexpected or uncontrolled movement or collapse of construction being demolished.
- C. Remove temporary barricades and protections where hazards no longer exist.

3.5 SELECTIVE DEMOLITION

- A. General: Demolish and remove existing construction only to the extent required by new construction and as indicated. Use methods required to complete the Work within limitations of governing regulations and as follows:
 - 1. Neatly cut openings and holes plumb, square, and true to dimensions required. Use cutting methods least likely to damage construction to remain or adjoining construction. Use hand tools or small power tools designed for sawing or grinding, not hammering and chopping. Temporarily cover openings to remain.
 - 2. Cut or drill from the exposed or finished side into concealed surfaces to avoid marring existing finished surfaces.
 - 3. Do not use cutting torches until work area is cleared of flammable materials. At concealed spaces, such as duct and pipe interiors, verify condition and contents of hidden space before starting flame-cutting operations. Maintain portable fire-suppression devices during flame-cutting operations.
 - 4. Maintain fire watch during and for at least 4 hours after flame-cutting operations.
 - 5. Locate selective demolition equipment and remove debris and materials so as not to impose excessive loads on supporting walls, floors, or framing.
 - 6. Dispose of demolished items and materials promptly. Comply with requirements in Section 017419 "Construction Waste Management and Disposal."
- B. Site Access and Temporary Controls: Conduct selective demolition and debris-removal operations to ensure minimum interference with roads, streets, walks, walkways, and other adjacent occupied and used facilities.
- C. Removed and Salvaged Items:
 - 1. Clean salvaged items.
 - 2. Pack or crate items after cleaning. Identify contents of containers.
 - 3. Store items in a secure area until delivery to Owner.
 - 4. Transport items to Owner's storage area off-site.
 - 5. Protect items from damage during transport and storage.

D. Removed and Reinstalled Items:

1. Clean and repair items to functional condition adequate for intended reuse.
2. Pack or crate items after cleaning and repairing. Identify contents of containers.
3. Protect items from damage during transport and storage.
4. Reinstall items in locations indicated. Comply with installation requirements for new materials and equipment. Provide connections, supports, and miscellaneous materials necessary to make item functional for use indicated.

E. Existing Items to Remain: Protect construction indicated to remain against damage and soiling during selective demolition. When permitted by Architect, items may be removed to a suitable, protected storage location during selective demolition and cleaned and reinstalled in their original locations after selective demolition operations are complete.

3.6 CLEANING

A. Remove demolition waste materials from Project site and dispose of them in an EPA-approved construction and demolition waste landfill acceptable to authorities having jurisdiction. and recycle or dispose of them.

1. Do not allow demolished materials to accumulate on-site.
2. Remove and transport debris in a manner that will prevent spillage on adjacent surfaces and areas.
3. Remove debris from elevated portions of building by chute, hoist, or other device that will convey debris to grade level in a controlled descent.

B. Baurning: Do not burn demolished materials.

C. Clean adjacent structures and improvements of dust, dirt, and debris caused by selective demolition operations. Return adjacent areas to condition existing before selective demolition operations began.

END OF SECTION 024119

SECTION 030130 - MAINTENANCE OF CAST-IN-PLACE CONCRETE

PART 1 - GENERAL

1.1 SUMMARY

A. Section Includes:

1. Removal of deteriorated concrete and subsequent patching.

1.2 UNIT PRICES

- A. General: Unit prices include the cost of preparing existing construction to receive the work indicated.

1.3 PREINSTALLATION MEETINGS

- A. Preinstallation Conference: Conduct conference at.

1.4 ACTION SUBMITTALS

- A. Product Data: For each type of product.
- B. Samples: Cured Samples for each exposed product and for each color and texture specified.

1.5 INFORMATIONAL SUBMITTALS

- A. Material certificates.
- B. Product test reports.
- C. Field quality-control reports.

1.6 QUALITY ASSURANCE

- A. Concrete-Maintenance Specialist Qualifications: Engage an experienced concrete-maintenance firm that employs installers and supervisors who are trained and approved by manufacturer to apply to perform work of this Section. Firm shall have completed work similar in material, design, and extent to that indicated for this Project with a record of successful in-service performance. Experience in only installing or patching new concrete is insufficient experience for concrete-maintenance work.

PART 2 - PRODUCTS

2.1 MANUFACTURERS

- A. Source Limitations: For repair products, obtain each color, grade, finish, type, and variety of product from single source and from single manufacturer with resources to provide products of consistent quality in appearance and physical properties.

2.2 BONDING AGENTS

- A. Epoxy-Modified, Cementitious Bonding and Anticorrosion Agent: Manufactured product that consists of water-insensitive epoxy adhesive, portland cement, and water-based solution of corrosion-inhibiting chemicals that forms a protective film on steel reinforcement.

2.3 PATCHING MORTAR

- A. Patching Mortar Requirements:
 - 1. Only use non-sag concrete repair mortar with integral corrosion inhibitor for vertical that are recommended by manufacturer for each applicable vertical, or overhead use orientation.
 - 2. Compressive Strength: Not less than at when tested according to ASTM C109/C109M.
- B. Polymer-Modified, Silica-Fume-Enhanced, Cementitious Patching Mortar: Packaged, dry mix for repair of concrete and that contains silica fume complying with ASTM C1240 and a latex additive as either a dry powder or a separate liquid that is added during mixing.

2.4 MISCELLANEOUS MATERIALS

- A. Portland Cement: ASTM C150/C150M, Type I, II, or III unless otherwise indicated.
- B. Water: Potable.

2.5 MIXES

- A. General: Mix products, in clean containers, according to manufacturer's written instructions.
- B. Dry-Pack Mortar: Mix required type(s) of patching-mortar dry ingredients with just enough liquid to form damp cohesive mixture that can be squeezed by hand into a ball but is not plastic.

PART 3 - EXECUTION

3.1 CONCRETE MAINTENANCE

- A. Have concrete-maintenance work performed only by qualified concrete-maintenance specialist.

- B. Comply with manufacturers' written instructions for surface preparation and product application.

3.2 EXAMINATION

- A. Notify Architect seven days in advance of dates when areas of deteriorated or delaminated concrete and deteriorated reinforcing bars will be located.
- B. Locate areas of deteriorated or delaminated concrete using hammer or chain-drag sounding and mark boundaries. Mark areas for removal by simplifying and squaring off boundaries. At columns and walls make boundaries level and plumb unless otherwise indicated.
- C. Perform surveys as the Work progresses to detect hazards resulting from concrete-maintenance work.

3.3 PREPARATION

- A. Ensure that supervisory personnel are on-site and on duty when concrete maintenance work begins and during its progress.
- B. Protect persons, motor vehicles, surrounding surfaces of building being repaired, building site, plants, and surrounding buildings from harm resulting from concrete maintenance work.
 - 1. Comply with each product manufacturer's written instructions for protections and precautions.
 - 2. Contain dust and debris generated by concrete maintenance work and prevent it from reaching the public or adjacent surfaces.
 - 3. Protect floors and other surfaces along haul routes from damage, wear, and staining.
- C. Preparation for Concrete Removal: Make explorations, probes, and inquiries as necessary to determine condition of construction to be removed in the course of repair.
 - 1. Verify that affected utilities have been disconnected and capped.
 - 2. Provide and maintain shoring, bracing, and temporary structural supports as required to preserve stability and prevent unexpected or uncontrolled movement, settlement, or collapse of construction being demolished and construction and finishes to remain. Strengthen or add new supports when required during progress of removal work.
- D. Reinforcing-Bar Preparation: Remove loose and flaking rust from exposed reinforcing bars until only tightly adhered light rust remains.
 - 1. Where section loss of reinforcing bar is more than 10 percent, cut bars and remove and replace as indicated on Drawings.
 - 2. Remove additional concrete as necessary to provide at least **3/4-inch (19-mm)** clearance at existing and replacement bars.
 - 3. Splice replacement bars to existing bars according to **ACI 318 (ACI 318M)** by welding, or using mechanical couplings if the size of the concrete element allows it.

3.4 REMOVAL OF CONCRETE

- A. Do not overload structural elements with debris.
- B. Saw-cut perimeter of areas indicated for removal to a depth of at least. Make cuts perpendicular to concrete surfaces and no deeper than cover on reinforcement.
- C. Remove deteriorated and delaminated concrete by breaking up and dislodging from reinforcement.
- D. Remove additional concrete if necessary to provide a depth of removal of at least over entire removal area.
- E. Remove concrete from entire perimeter of bar and to provide at least **3/4-inch (19-mm)** clearance around bar, or as required to allow any required work around the rebar.
- F. Test areas where concrete has been removed by tapping with hammer, and remove additional concrete until unsound and disbonded concrete is completely removed.
- G. Provide surfaces with a fractured profile of at least **1/8 inch (3 mm)** that are approximately perpendicular or parallel to original concrete surfaces. At columns and walls, make top and bottom surfaces level unless otherwise directed.
- H. Thoroughly clean removal areas of loose concrete, dust, and debris.

3.5 APPLICATION OF BONDING AGENT

- A. Epoxy-Modified, Cementitious Bonding and Anticorrosion Agent: Apply to reinforcing bars following manufacturer's recommendations.

3.6 INSTALLATION OF PATCHING MORTAR

- A. Place patching mortar as specified in this article unless otherwise recommended in writing by manufacturer.
 - 1. Provide forms where necessary to confine patch to required shape.
 - 2. Wet substrate and forms thoroughly and then remove standing water.
- B. Pretreatment: Apply specified.
- C. General Placement: Place patching mortar by troweling toward edges of patch to force intimate contact with edge surfaces. For large patches, fill edges first and then work toward center, always troweling toward edges of patch. At fully exposed reinforcing bars, force patching mortar to fill space behind bars by compacting with trowel from sides of bars.
- D. Vertical Patching: Place material in lifts of not more than thickness recommended by manufacturer. Do not feather edge.
- E. Overhead Patching: Place material in lifts of not more than thickness recommended by manufacturer. Do not feather edge.

- F. Consolidation: After each lift is placed, consolidate material and screed surface.
- G. Multiple Lifts: Where multiple lifts are used, score surface of lifts to provide a rough surface for placing subsequent lifts. Allow each lift to reach final set before placing subsequent lifts.
- H. Finishing: Allow surfaces of lifts that are to remain exposed to become firm and then finish to a.
- I. Curing: Wet-cure cementitious patching materials, including polymer-modified cementitious patching materials, for not less than seven days by water-fog spray or water-saturated absorptive cover.

3.7 FIELD QUALITY CONTROL

- A. Testing Agency: a qualified testing agency to perform tests and inspections.
- B. Product will be considered defective if it does not pass tests and inspections.
- C. Prepare test and inspection reports.

END OF SECTION 030130

SECTION 030130 - MAINTENANCE OF CAST-IN-PLACE CONCRETE

PART 1 - GENERAL

1.1 SUMMARY

A. Section Includes:

1. Removal of deteriorated concrete and subsequent patching.

1.2 UNIT PRICES

- A. Work of this Section is affected by unit prices specified in Section 012200 "Unit Prices."
- B. General: Unit prices include the cost of preparing existing construction to receive the work indicated.

1.3 PREINSTALLATION MEETINGS

- A. Preinstallation Conference: Conduct conference at.

1.4 ACTION SUBMITTALS

- A. Product Data: For each type of product.
- B. Samples: Cured Samples for each exposed product and for each color and texture specified.

1.5 INFORMATIONAL SUBMITTALS

- A. Material certificates.
- B. Product test reports.
- C. Field quality-control reports.

1.6 QUALITY ASSURANCE

- A. Concrete-Maintenance Specialist Qualifications: Engage an experienced concrete-maintenance firm that employs installers and supervisors who are trained and approved by manufacturer to apply to perform work of this Section. Firm shall have completed work similar in material, design, and extent to that indicated for this Project with a record of successful in-service performance. Experience in only installing or patching new concrete is insufficient experience for concrete-maintenance work.

PART 2 - PRODUCTS

2.1 MANUFACTURERS

- A. Source Limitations: For repair products, obtain each color, grade, finish, type, and variety of product from single source and from single manufacturer with resources to provide products of consistent quality in appearance and physical properties.

2.2 BONDING AGENTS

- A. Epoxy-Modified, Cementitious Bonding and Anticorrosion Agent: Manufactured product that consists of water-insensitive epoxy adhesive, portland cement, and water-based solution of corrosion-inhibiting chemicals that forms a protective film on steel reinforcement.

2.3 PATCHING MORTAR

- A. Patching Mortar Requirements:
 - 1. Only use non-sag concrete repair mortar with integral corrosion inhibitor for vertical that are recommended by manufacturer for each applicable vertical, or overhead use orientation.
 - 2. Compressive Strength: Not less than at when tested according to ASTM C109/C109M.
- B. Polymer-Modified, Silica-Fume-Enhanced, Cementitious Patching Mortar: Packaged, dry mix for repair of concrete and that contains silica fume complying with ASTM C1240 and a latex additive as either a dry powder or a separate liquid that is added during mixing.

2.4 Repair Mortar System Shrinkage Compensated Repair Mortar

- A. One- or two-component cement-based, flowable, shrinkage compensated repair mortar system.
- B. Compressive Strength, ASTM C109/C109M:
 - 1. 1 Day: 2,500 psi minimum.
 - 2. 7 Days: 6,000 psi minimum.
 - 3. 28 Days: 8,000 psi minimum.
- C. Flexural Strength, ASTM C348 at 28 Days: 770 psi minimum.
- D. Modulus of Elasticity, ASTM C469 at 28 Days: 5.9 by 106 psi minimum.
- E. Slant Shear Bond Strength, ASTM C882/C882M Modified:
 - 1. 7 Days: 2,150 psi minimum.
 - 2. 28 Days: 3,000 psi minimum.
- F. Freeze-thaw Resistance, ASTM C666/C666M, Procedure A, at 300 Cycles: 97.0 percent RDM.
- G. Chloride Ion Permeability Based on Charge Passed, ASTM C1202 at 28 Days: 650 coulombs maximum.

- H. Sulfate Resistance, ASTM C1012/C1012M after 6 Months: 0.01 percent length change maximum.
- I. Application
 - 1. Patches, joints, or overlays 1 inch thick or greater. Return to service in 7 days or more.
- J. Placement
 - 1. Remove standing and free water from prepared area.
 - 2. Apply bond scrub coat of mortar to prepared surface in accordance with manufacturer's instructions. Do not apply more scrub coat of mortar than can be covered with repair mortar before scrub coat begins drying.
 - 3. Immediately place mixed repair mortar into prepared area from one side to the other side.
 - 4. Work material firmly into bottom and sides of patch to ensure a good continuous bond.
 - 5. Level repair mortar and screed to elevation of existing concrete.
 - 6. Finish to same texture as existing concrete around patch.
 - 7. Use self-leveling mixture to obtain a uniform and plane surface.
- K. Curing
 - 1. Apply curing compound in accordance with Section 033000 - Cast-In-Place Concrete.

2.5 MISCELLANEOUS MATERIALS

- A. Portland Cement: ASTM C150/C150M, Type I, II, or III unless otherwise indicated.
- B. Water: Potable.

2.6 MIXES

- A. General: Mix products, in clean containers, according to manufacturer's written instructions.
- B. Dry-Pack Mortar: Mix required type(s) of patching-mortar dry ingredients with just enough liquid to form damp cohesive mixture that can be squeezed by hand into a ball but is not plastic.

PART 3 - EXECUTION

3.1 CONCRETE MAINTENANCE

- A. Have concrete-maintenance work performed only by qualified concrete-maintenance specialist.
- B. Comply with manufacturers' written instructions for surface preparation and product application.

3.2 EXAMINATION

- A. Notify Architect seven days in advance of dates when areas of deteriorated or delaminated concrete and deteriorated reinforcing bars will be located.
- B. Locate areas of deteriorated or delaminated concrete using hammer or chain-drag sounding and mark boundaries. Mark areas for removal by simplifying and squaring off boundaries. At columns and walls make boundaries level and plumb unless otherwise indicated.
- C. Perform surveys as the Work progresses to detect hazards resulting from concrete-maintenance work.

3.3 PREPARATION

- A. Ensure that supervisory personnel are on-site and on duty when concrete maintenance work begins and during its progress.
- B. Protect persons, motor vehicles, surrounding surfaces of building being repaired, building site, plants, and surrounding buildings from harm resulting from concrete maintenance work.
 - 1. Comply with each product manufacturer's written instructions for protections and precautions.
 - 2. Contain dust and debris generated by concrete maintenance work and prevent it from reaching the public or adjacent surfaces.
 - 3. Protect floors and other surfaces along haul routes from damage, wear, and staining.
- C. Preparation for Concrete Removal: Make explorations, probes, and inquiries as necessary to determine condition of construction to be removed in the course of repair.
 - 1. Verify that affected utilities have been disconnected and capped.
 - 2. Provide and maintain shoring, bracing, and temporary structural supports as required to preserve stability and prevent unexpected or uncontrolled movement, settlement, or collapse of construction being demolished and construction and finishes to remain. Strengthen or add new supports when required during progress of removal work.
- D. Reinforcing-Bar Preparation: Remove loose and flaking rust from exposed reinforcing bars until only tightly adhered light rust remains.
 - 1. Where section loss of reinforcing bar is more than 10 percent, cut bars and remove and replace as indicated on Drawings.
 - 2. Remove additional concrete as necessary to provide at least **3/4-inch (19-mm)** clearance at existing and replacement bars.
 - 3. Splice replacement bars to existing bars according to **ACI 318 (ACI 318M)** by welding, or using mechanical couplings if the size of the concrete element allows it.

3.4 REMOVAL OF CONCRETE

- A. Do not overload structural elements with debris.

- B. Saw-cut perimeter of areas indicated for removal to a depth of at least. Make cuts perpendicular to concrete surfaces and no deeper than cover on reinforcement.
- C. Remove deteriorated and delaminated concrete by breaking up and dislodging from reinforcement.
- D. Remove additional concrete if necessary to provide a depth of removal of at least over entire removal area.
- E. Remove concrete from entire perimeter of bar and to provide at least **3/4-inch (19-mm)** clearance around bar, or as required to allow any required work around the rebar.
- F. Test areas where concrete has been removed by tapping with hammer, and remove additional concrete until unsound and disbonded concrete is completely removed.
- G. Provide surfaces with a fractured profile of at least **1/8 inch (3 mm)** that are approximately perpendicular or parallel to original concrete surfaces. At columns and walls, make top and bottom surfaces level unless otherwise directed.
- H. Thoroughly clean removal areas of loose concrete, dust, and debris.

3.5 APPLICATION OF BONDING AGENT

- A. Epoxy-Modified, Cementitious Bonding and Anticorrosion Agent: Apply to reinforcing bars following manufacturer's recommendations.

3.6 INSTALLATION OF PATCHING MORTAR

- A. Place patching mortar as specified in this article unless otherwise recommended in writing by manufacturer.
 - 1. Provide forms where necessary to confine patch to required shape.
 - 2. Wet substrate and forms thoroughly and then remove standing water.
- B. Pretreatment: Apply specified.
- C. General Placement: Place patching mortar by troweling toward edges of patch to force intimate contact with edge surfaces. For large patches, fill edges first and then work toward center, always troweling toward edges of patch. At fully exposed reinforcing bars, force patching mortar to fill space behind bars by compacting with trowel from sides of bars.
- D. Vertical Patching: Place material in lifts of not more than thickness recommended by manufacturer. Do not feather edge.
- E. Overhead Patching: Place material in lifts of not more than thickness recommended by manufacturer. Do not feather edge.
- F. Consolidation: After each lift is placed, consolidate material and screed surface.

- G. Multiple Lifts: Where multiple lifts are used, score surface of lifts to provide a rough surface for placing subsequent lifts. Allow each lift to reach final set before placing subsequent lifts.
- H. Finishing: Allow surfaces of lifts that are to remain exposed to become firm and then finish to a.
- I. Curing: Wet-cure cementitious patching materials, including polymer-modified cementitious patching materials, for not less than seven days by water-fog spray or water-saturated absorptive cover.

3.7 FIELD QUALITY CONTROL

- A. Testing Agency: a qualified testing agency to perform tests and inspections.
- B. Product will be considered defective if it does not pass tests and inspections.
- C. Prepare test and inspection reports.

END OF SECTION 030130

SECTION 033000 - CAST-IN-PLACE CONCRETE

PART 1 - GENERAL

1.1 SUMMARY

A. Section Includes:

1. Cast-in-place concrete, including concrete materials, mixture design, placement procedures, and finishes.

1.2 ACTION SUBMITTALS

A. Product Data: For each type of manufactured material and product indicated.

B. Design Mixtures: For each concrete mixture.

1. Indicate amounts of mixing water to be withheld for later addition at Project site if permitted.
2. Submit alternate design mixtures when characteristics of materials, Project conditions, weather, test results, or other circumstances warrant adjustments.

C. Concrete Schedule: For each location of each Class of concrete indicated in "Concrete Mixtures" Article, including the following:

1. Concrete Class designation.
2. Location within Project.
3. Exposure Class designation.
4. Formed Surface Finish designation and final finish.
5. Final finish for floors.
6. Curing process.
7. Floor treatment if any.

1.3 INFORMATIONAL SUBMITTALS

A. Material Certificates: For each of the following, signed by manufacturers:

1. Cementitious materials.
2. Admixtures.
3. Curing compounds.
4. Vapor retarders.
5. Joint-filler strips.

B. Material Test Reports: For the following, from a qualified testing agency:

1. Cementitious materials and aggregates.
2. Admixtures.
3. Curing materials.

4. Floor and slab treatment.
 5. Vapor retarders.
- C. Field quality-control reports.

1.4 QUALITY ASSURANCE

- A. Ready-Mixed Concrete Manufacturer Qualifications: A firm experienced in manufacturing ready-mixed concrete products and that complies with ASTM C94/C94M requirements for production facilities and equipment. Manufacturer must be certified according to the National Ready Mixed Concrete Association's Certification of Ready Mixed Concrete Production Facilities.
- B. Installer Qualifications: An experienced installer who has completed concrete Work similar in material, design, and extent to that indicated for this Project and whose work has resulted in construction with a record of successful in-service performance.
- C. Testing Agency Qualifications: An independent testing agency, acceptable to authorities having jurisdiction, qualified according to ASTM C 1077 and ASTM E 329 to conduct the testing indicated, as documented according to ASTM E 548.
- D. Source Limitations: Obtain each type or class of cementitious material of the same brand from the same manufacturer's plant, each aggregate from one source, and each admixture from the same manufacturer.
- E. ACI Publications: Comply with the following, unless more stringent provisions are indicated:
1. ACI 301, "Specification for Structural Concrete."
 2. ACI 117, "Specifications for Tolerances for Concrete Construction and Materials."
- F. Coordinate all penetrations with Architect, plumbing, mechanical, electrical contractors and local agencies.

1.5 DELIVERY, STORAGE, AND HANDLING

- A. Deliver, store, and handle steel reinforcement to prevent bending and damage.

PART 2 - PRODUCTS

2.1 CONCRETE MATERIALS

- A. Portland Cement: ASTM C150, [**Type I**] or [**Type II**].
- B. Normal-Weight Aggregates: ASTM C33, uniformly graded. Provide aggregates from a single source.
1. Maximum Coarse-Aggregate Size: [**1 inch (25 mm)**] nominal.
 2. Fine Aggregate: Free of materials with deleterious reactivity to alkali in cement.

- C. Water: Potable and complying with ASTM C 94.

2.2 VAPOR RETARDERS

- A. Sheet Vapor Retarder, Class A: ASTM E1745, Class C; not less than 10 mils (0.25 mm) thick. Include manufacturer's recommended adhesive or pressure-sensitive tape.

2.3 CURING MATERIALS

- A. Absorptive Cover: AASHTO M 182, Class 2, burlap cloth made from jute or kenaf, weighing approximately 9 oz./sq. yd. (305 g/sq. m) when dry.
- B. Moisture-Retaining Cover: ASTM C171, polyethylene film burlap-polyethylene sheet.
- C. Water: Potable.
- D. Clear, Waterborne, Membrane-Forming, Dissipating Curing Compound: ASTM C309, Type 1, Class B.
- E. Clear, Waterborne, Membrane-Forming, Curing and Sealing Compound: ASTM C1315, Type 1, Class A.

2.4 RELATED MATERIALS

- A. Expansion- and Isolation-Joint-Filler Strips: [**ASTM D1751, asphalt-saturated cellulosic fiber**].

2.5 CONCRETE MIXTURES, GENERAL

- A. Prepare design mixtures for each type and strength of concrete, proportioned on the basis of laboratory trial mixture or field test data, or both, in accordance with ACI 301 (ACI 301M).
 - 1. Use a qualified testing agency for preparing and reporting proposed mixture designs, based on laboratory trial mixtures.
- B. Cementitious Materials: Limit percentage, by weight, of cementitious materials other than portland cement in concrete as follows:
 - 1. Fly Ash or Other Pozzolans: 25 percent by mass.
 - 2. Slag Cement: 50 percent by mass.
 - 3. Total of Fly Ash or Other Pozzolans, Slag Cement: 50 percent by mass, with fly ash or pozzolans not exceeding 25 percent by mass.
 - 4. Total of Fly Ash or Other Pozzolans: 35 percent by mass with fly ash or pozzolans not exceeding 25 percent by mass.

2.6 CONCRETE MIXTURES

- A. All concrete, unless noted otherwise: Proportion normal-weight concrete mix as follows:
 - 1. Compressive Strength (28 Days): 3000 psi.
 - 2. Maximum Slump: 4 inches.
 - 3. Maximum Water-Cementitious Materials Ratio: 0.65
- B. Air Content: Add air-entraining admixture at manufacturer's prescribed rate to result in concrete at point of placement having an air content as follows within a tolerance of plus 1 or minus 1.5 percent, unless otherwise indicated:
 - 1. Air Content: 5.5 percent for 1-1/2-inch- nominal maximum aggregate size.
 - 2. Air Content: 6 percent for 1-inch- nominal maximum aggregate size.
 - 3. Air Content: 6 percent for 3/4-inch- nominal maximum aggregate size.
- C. Do not air entrain concrete to trowel-finished interior floors and suspended slabs. Do not allow entrapped air content to exceed 3 percent.
- D. Limit water-soluble, chloride-ion content in hardened concrete to 0.15 percent by weight of cement.
- E. Project-Site Mixing: Measure, batch, and mix concrete materials and concrete in accordance with ASTM C94/C94M. Mix concrete materials in appropriate drum-type batch machine mixer.
 - 1. For mixer capacity of 1 cu. yd. (0.76 cu. m) or smaller, continue mixing at least 1-1/2 minutes, but not more than five minutes after ingredients are in mixer, before any part of batch is released.
 - 2. For mixer capacity larger than 1 cu. yd. (0.76 cu. m), increase mixing time by 15 seconds for each additional 1 cu. yd. (0.76 cu. m).
 - 3. Provide batch ticket for each batch discharged and used in the Work, indicating Project identification name and number, date, mixture type, mixture time, quantity, and amount of water added. Record approximate location of final deposit in structure.

2.7 FABRICATING REINFORCEMENT

- A. Fabricate steel reinforcement according to CRSI's "Manual of Standard Practice."

2.8 CONCRETE MIXING

- A. Ready-Mixed Concrete: Measure, batch, mix, and deliver concrete according to ASTM C 94 and ASTM C 1116, and furnish batch ticket information.
 - 1. When air temperature is between 85 and 90 deg F, reduce mixing and delivery time from 1-1/2 hours to 75 minutes; when air temperature is above 90 deg F, reduce mixing and delivery time to 60 minutes.

PART 3 - EXECUTION

3.1 FORMWORK

- A. Design, erect, shore, brace, and maintain formwork, according to ACI 301, to support vertical, lateral, static, and dynamic loads, and construction loads that might be applied, until concrete structure can support such loads.
- B. Construct formwork so concrete members and structures are of size, shape, alignment, elevation, and position indicated, within tolerance limits of ACI 117.

3.2 EMBEDDED ITEMS

- A. Place and secure anchorage devices and other embedded items required for adjoining Work that is attached to or supported by cast-in-place concrete.
 - 1. Use setting drawings, templates, diagrams, instructions, and directions furnished with items to be embedded.
 - 2. Install anchor rods, accurately located, to elevations required and complying with tolerances in Section 7.5 of ANSI/AISC 303.

3.3 VAPOR RETARDER

- A. Sheet Vapor Retarders: Place, protect, and repair sheet vapor retarder in accordance with ASTM E1643 and manufacturer's written instructions.

3.4 STEEL REINFORCEMENT

- A. General: Comply with CRSI's "Manual of Standard Practice" for placing reinforcement.
 - 1. Do not cut or puncture vapor retarder. Repair damage and reseal vapor retarder before placing concrete.
- B. Clean reinforcement of loose rust and mill scale, earth, and other foreign materials.
- C. Accurately position, support, and secure reinforcement against displacement. Locate and support reinforcement with bar supports to maintain minimum concrete cover. Do not tack weld crossing reinforcing bars.
 - 1. Shop- or field-weld reinforcement according to AWS D1.4, where indicated.
- D. Set wire ties with ends directed into concrete, not toward exposed concrete surfaces.

3.5 JOINTS

- A. General: Construct joints true to line, with faces perpendicular to surface plane of concrete.
- B. Construction Joints: Coordinate with floor slab pattern and concrete placement sequence.

1. Install so strength and appearance of concrete are not impaired, at locations indicated on Drawings or as approved by Architect.
 2. Place joints perpendicular to main reinforcement.
 - a. Continue reinforcement across construction joints unless otherwise indicated.
 - b. Do not continue reinforcement through sides of strip placements of floors and slabs.
- C. Control Joints in Slabs-on-Ground: Form weakened-plane control joints, sectioning concrete into areas as indicated. Construct control joints for a depth equal to at least **[one-fourth]** of concrete thickness as follows:
1. Grooved Joints: Form control joints after initial floating by grooving and finishing each edge of joint to a radius of 1/8 inch (3.2 mm). Repeat grooving of control joints after applying surface finishes. Eliminate groover tool marks on concrete surfaces.
 2. Sawed Joints: Form control joints with power saws equipped with shatterproof abrasive or diamond-rimmed blades. Cut 1/8-inch- (3.2-mm-) wide joints into concrete when cutting action does not tear, abrade, or otherwise damage surface and before concrete develops random cracks.
- D. Isolation Joints in Slabs-on-Ground: After removing formwork, install joint-filler strips at slab junctions with vertical surfaces, such as column pedestals, foundation walls, grade beams, and other locations, as indicated.
1. Extend joint-filler strips full width and depth of joint, terminating flush with finished concrete surface unless otherwise indicated on Drawings.
 2. Terminate full-width joint-filler strips not less than 1/2 inch (13 mm) or more than 1 inch (25 mm) below finished concrete surface, where joint sealants, specified in Section 079200 "Joint Sealants," are indicated.
 3. Install joint-filler strips in lengths as long as practicable. Where more than one length is required, lace or clip sections together.
- E. Doweled Joints:
1. Install dowel bars and support assemblies at joints where indicated on Drawings.
 2. Lubricate or asphalt coat one-half of dowel bar length to prevent concrete bonding to one side of joint.
- F. Dowel Plates: Install dowel plates at joints where indicated on Drawings.
- 3.6 CONCRETE PLACEMENT
- A. Before placing concrete, verify that installation of formwork, reinforcement, embedded items, and vapor retarder is complete and that required inspections are completed.
1. Immediately prior to concrete placement, inspect vapor retarder for damage and deficient installation, and repair defective areas.
 2. Provide continuous inspection of vapor retarder during concrete placement and make necessary repairs to damaged areas as Work progresses.

- B. Notify Architect and testing and inspection agencies 24 hours prior to commencement of concrete placement.
- C. Do not add water to concrete during delivery, at Project site, or during placement unless approved by Architect in writing, but not to exceed the amount indicated on the concrete delivery ticket.
 - 1. Do not add water to concrete after adding high-range water-reducing admixtures to mixture.
- D. Before test sampling and placing concrete, water may be added at Project site, subject to limitations of ACI 301 (ACI 301M), but not to exceed the amount indicated on the concrete delivery ticket.
 - 1. Do not add water to concrete after adding high-range water-reducing admixtures to mixture.
- E. Deposit concrete continuously in one layer or in horizontal layers of such thickness that no new concrete is placed on concrete that has hardened enough to cause seams or planes of weakness.
 - 1. If a section cannot be placed continuously, provide construction joints as indicated.
 - 2. Deposit concrete to avoid segregation.
 - 3. Deposit concrete in horizontal layers of depth not to exceed formwork design pressures and in a manner to avoid inclined construction joints.
 - 4. Consolidate placed concrete with mechanical vibrating equipment in accordance with ACI 301 (ACI 301M).
 - a. Do not use vibrators to transport concrete inside forms.
 - b. Insert and withdraw vibrators vertically at uniformly spaced locations to rapidly penetrate placed layer and at least 6 inches (150 mm) into preceding layer.
 - c. Do not insert vibrators into lower layers of concrete that have begun to lose plasticity.
 - d. At each insertion, limit duration of vibration to time necessary to consolidate concrete, and complete embedment of reinforcement and other embedded items without causing mixture constituents to segregate.
- F. Deposit and consolidate concrete for floors and slabs in a continuous operation, within limits of construction joints, until placement of a panel or section is complete.
 - 1. Do not place concrete floors and slabs in a checkerboard sequence.
 - 2. Consolidate concrete during placement operations, so concrete is thoroughly worked around reinforcement and other embedded items and into corners.
 - 3. Maintain reinforcement in position on chairs during concrete placement.
 - 4. Screed slab surfaces with a straightedge and strike off to correct elevations.
 - 5. Level concrete, cut high areas, and fill low areas.
 - 6. Slope surfaces uniformly to drains where required.
 - 7. Begin initial floating using bull floats or darbies to form a uniform and open-textured surface plane, before excess bleedwater appears on the surface.
 - 8. Do not further disturb slab surfaces before starting finishing operations.

3.7 FINISHING FLOORS AND SLABS

- A. Comply with ACI 302.1R recommendations for screeding, restraighening, and finishing operations for concrete surfaces. Do not wet concrete surfaces.
- B. Scratch Finish:
1. While still plastic, texture concrete surface that has been screeded and bull-floated or darbied.
 2. Use stiff brushes, brooms, or rakes to produce a profile depth of 1/4 inch (6 mm) in one direction.
 3. Apply scratch finish to surfaces **[to receive concrete floor toppings] [to receive mortar setting beds for bonded cementitious floor finishes] <Insert locations>**.
- C. Float Finish:
1. When bleedwater sheen has disappeared and concrete surface has stiffened sufficiently to permit operation of specific float apparatus, consolidate concrete surface with power-driven floats or by hand floating if area is small or inaccessible to power-driven floats.
 2. Repeat float passes and restraighening until surface is left with a uniform, smooth, granular texture and complies with ACI 117 (ACI A117M) tolerances for conventional concrete.
 3. Apply float finish to surfaces **[to receive trowel finish] [and] [to be covered with fluid-applied or sheet waterproofing, built-up or membrane roofing, or sand-bed terrazzo] <Insert locations>**.
- D. Trowel Finish:
1. After applying float finish, apply first troweling and consolidate concrete by hand or power-driven trowel.
 2. Continue troweling passes and restraighen until surface is free of trowel marks and uniform in texture and appearance.
 3. Grind smooth any surface defects that would telegraph through applied coatings or floor coverings.
 4. Do not add water to concrete surface.
 5. Do not apply hard-troweled finish to concrete, which has a total air content greater than 3 percent.
 6. Apply a trowel finish to surfaces indicated and to floor and slab surfaces exposed to view or to be covered with resilient flooring, carpet, or another thin film-finish coating system.
 7. Finish and measure surface, so gap at any point between concrete surface and an unlevelled, freestanding, 10-ft.- (3.05-m-) long straightedge resting on two high spots and placed anywhere on the surface does not exceed **[1/8 inch (3 mm)and also no more than 1/16 inch (1.6 mm) in 2 feet (610 mm)]**.
- E. Slip-Resistive Finish: Before final floating, apply slip-resistive **[aggregate]** finish to concrete stair treads, platforms, ramps as indicated on Drawings
1. Apply in accordance with manufacturer's written instructions and as follows:
 - a. Uniformly spread **[25 lb/100 sq. ft. (12 kg/10 sq. m)]** of dampened slip-resistive **[aggregate]** over surface in one or two applications.

- b. Tamp aggregate flush with surface, but do not force below surface.
- c. After broadcasting and tamping, apply float finish.
- d. After curing, lightly work surface with a steel wire brush or an abrasive stone and water to expose slip-resistive [**aggregate**].

3.8 INSTALLATION OF MISCELLANEOUS CONCRETE ITEMS

- A. Filling In: Fill in holes and openings left in concrete structures, unless otherwise indicated, after work of other trades is in place. Mix, place, and cure concrete, as specified, to blend with in-place construction. Provide other miscellaneous concrete filling indicated or required to complete Work.
- B. Curbs: Provide monolithic finish to interior curbs by stripping forms while concrete is still green and by steel-troweling surfaces to a hard, dense finish with corners, intersections, and terminations slightly rounded.
- C. Equipment Bases and Foundations: Provide machine and equipment bases and foundations as shown on Drawings. Set anchor bolts for machines and equipment at correct elevations, complying with diagrams or templates of manufacturer furnishing machines and equipment.

3.9 CONCRETE CURING

- A. Protect freshly placed concrete from premature drying and excessive cold or hot temperatures.
 1. Comply with ACI 301 (ACI 301M) and ACI 305.1 (ACI 305.1M) for hot-weather protection during curing.
 2. Cure formed concrete surfaces, including underside of beams, supported slabs, and other similar surfaces.
 3. Cure concrete containing color pigments in accordance with color pigment manufacturer's instructions.
 4. If forms remain during curing period, moist cure after loosening forms.
 5. If removing forms before end of curing period, continue curing for remainder of curing period, as follows:
 - a. Continuous Fogging: Maintain standing water on concrete surface until final setting of concrete.
 - b. Continuous Sprinkling: Maintain concrete surface continuously wet.
 - c. Absorptive Cover: Pre-dampen absorptive material before application; apply additional water to absorptive material to maintain concrete surface continuously wet.
 - d. Water-Retention Sheeting Materials: Cover exposed concrete surfaces with sheeting material, taping, or lapping seams.
 - e. Membrane-Forming Curing Compound: Apply uniformly in continuous operation by power spray or roller in accordance with manufacturer's written instructions.
 - 1) Recoat areas subject to heavy rainfall within three hours after initial application.
 - 2) Maintain continuity of coating and repair damage during curing period.

B. Curing Unformed Surfaces: Comply with ACI 308.1 (ACI 308.1M) as follows:

1. Begin curing immediately after finishing concrete.
2. Interior Concrete Floors:
 - a. Floors to Receive Floor Coverings Specified in Other Sections: Contractor has option of the following:
 - 1) Absorptive Cover: As soon as concrete has sufficient set to permit application without marring concrete surface, install prewetted absorptive cover over entire area of floor.
 - a) Lap edges and ends of absorptive cover not less than 12 inches (300 mm).
 - b) Maintain absorptive cover water saturated, and in place, for duration of curing period, but not less than seven days.
 - 2) Moisture-Retaining-Cover Curing: Cover concrete surfaces with moisture-retaining cover for curing concrete, placed in widest practicable width, with sides and ends lapped at least 12 inches (300 mm), and sealed by waterproof tape or adhesive.
 - a) Immediately repair any holes or tears during curing period, using cover material and waterproof tape.
 - b) Cure for not less than seven days.
 - 3) Ponding or Continuous Sprinkling of Water: Maintain concrete surfaces continuously wet for not less than seven days, utilizing one, or a combination of, the following:
 - a) Water.
 - b) Continuous water-fog spray.
 - b. Floors to Receive Curing Compound:
 - 1) Apply uniformly in continuous operation by power spray or roller in accordance with manufacturer's written instructions.
 - 2) Recoat areas subjected to heavy rainfall within three hours after initial application.
 - 3) Maintain continuity of coating, and repair damage during curing period.
 - 4) Removal: After curing period has elapsed, remove curing compound without damaging concrete surfaces by method recommended by curing compound manufacturer[**unless manufacturer certifies curing compound does not interfere with bonding of floor covering used on Project**].
 - c. Floors to Receive Curing and Sealing Compound:
 - 1) Apply uniformly to floors and slabs indicated in a continuous operation by power spray or roller in accordance with manufacturer's written instructions.
 - 2) Recoat areas subjected to heavy rainfall within three hours after initial application.

- 3) Repeat process 24 hours later, and apply a second coat. Maintain continuity of coating, and repair damage during curing period.

3.10 TOLERANCES

- A. Conform to ACI 117 (ACI 117M).

3.11 FIELD QUALITY CONTROL

- A. Testing Agency: [**Engage**] a qualified testing and inspecting agency to perform tests and inspections and to submit reports.

1. Testing agency to be responsible for providing curing container for composite samples on Site and verifying that field-cured composite samples are cured in accordance with ASTM C31/C31M.
2. Testing agency to immediately report to Architect, Contractor, and concrete manufacturer any failure of Work to comply with Contract Documents.
3. Testing agency shall report results of tests and inspections, in writing, to Owner, Architect, Contractor, and concrete manufacturer within 48 hours of inspections and tests.

- a. Test reports to include reporting requirements of ASTM C31/C31M, ASTM C39/C39M, and ACI 301, including the following as applicable to each test and inspection:

- 1) Project name.
- 2) Name of testing agency.
- 3) Names and certification numbers of field and laboratory technicians performing inspections and testing.
- 4) Name of concrete manufacturer.
- 5) Date and time of inspection, sampling, and field testing.
- 6) Date and time of concrete placement.
- 7) Location in Work of concrete represented by samples.
- 8) Date and time sample was obtained.
- 9) Truck and batch ticket numbers.
- 10) Design compressive strength at 28 days.
- 11) Concrete mixture designation, proportions, and materials.
- 12) Field test results.
- 13) Information on storage and curing of samples before testing, including curing method and maximum and minimum temperatures during initial curing period.
- 14) Type of fracture and compressive break strengths at seven days and 28 days.

- B. Batch Tickets: For each load delivered, submit three copies of batch delivery ticket to testing agency, indicating quantity, mix identification, admixtures, design strength, aggregate size, design air content, design slump at time of batching, and amount of water that can be added at Project site.

- C. Inspections:

1. Headed bolts and studs.
 2. Verification of use of required design mixture.
 3. Concrete placement, including conveying and depositing.
 4. Curing procedures and maintenance of curing temperature.
 5. Verification of concrete strength before removal of shores and forms from beams and slabs.
 6. Batch Plant Inspections: On a random basis, as determined by Architect.
- D. Concrete Tests: Testing of composite samples of fresh concrete obtained in accordance with ASTM C 172/C 172M shall be performed in accordance with the following requirements:
1. Testing Frequency: Obtain one composite sample for each day's pour of each concrete mixture exceeding 5 cu. yd. (4 cu. m), but less than 25 cu. yd. (19 cu. m), plus one set for each additional 50 cu. yd. (38 cu. m) or fraction thereof.
 - a. When frequency of testing provides fewer than five compressive-strength tests for each concrete mixture, testing to be conducted from at least five randomly selected batches or from each batch if fewer than five are used.
 2. Slump: ASTM C143/C143M:
 - a. One test at point of placement for each composite sample, but not less than one test for each day's pour of each concrete mixture.
 - b. Perform additional tests when concrete consistency appears to change.
 3. Slump Flow: ASTM C1611/C1611M:
 - a. One test at point of placement for each composite sample, but not less than one test for each day's pour of each concrete mixture.
 - b. Perform additional tests when concrete consistency appears to change.
 4. Air Content: ASTM C231/C231M pressure method, for normal-weight concrete; **[ASTM C173/C173M volumetric method, for structural lightweight concrete]**.
 - a. One test for each composite sample, but not less than one test for each day's pour of each concrete mixture.
 5. Concrete Temperature: ASTM C1064/C1064M:
 - a. One test hourly when air temperature is 40 deg F (4.4 deg C) and below or 80 deg F (27 deg C) and above, and one test for each composite sample.
 6. Compression Test Specimens: ASTM C31/C31M:
 - a. Cast and laboratory cure two sets of **[four]** 6-inch (150 mm) by 12-inch (300 mm) or 4-inch (100 mm) by 8-inch (200 mm) cylinder specimens for each composite sample.
 - b. Cast, initial cure, and field cure **<one>** set of **[four]** standard cylinder specimens for each composite sample.
 7. Compressive-Strength Tests: ASTM C39/C39M.

- a. Test one set of [**two**] laboratory-cured specimens at seven days and one set of two specimens at 28 days.
 - b. Test one set of [**two**] field-cured specimens at seven days and one set of two specimens at 28 days.
 - c. A compressive-strength test to be the average compressive strength from a set of two specimens obtained from same composite sample and tested at age indicated.
8. When strength of field-cured cylinders is less than 85 percent of companion laboratory-cured cylinders, Contractor to evaluate operations and provide corrective procedures for protecting and curing in-place concrete.
 9. Strength of each concrete mixture will be satisfactory if every average of any three consecutive compressive-strength tests equals or exceeds specified compressive strength, and no compressive-strength test value falls below specified compressive strength by more than 500 psi (3.4 MPa) if specified compressive strength is 5000 psi (34.5 MPa), or no compressive strength test value is less than 10 percent of specified compressive strength if specified compressive strength is greater than 5000 psi (34.5 MPa).
 10. Nondestructive Testing: Impact hammer, sonoscope, or other nondestructive device may be permitted by Architect but will not be used as sole basis for approval or rejection of concrete.
 11. Additional Tests:
 - a. Testing and inspecting agency to make additional tests of concrete when test results indicate that slump, air entrainment, compressive strengths, or other requirements have not been met, as directed by Architect.
 - b. Testing and inspecting agency may conduct tests to determine adequacy of concrete by cored cylinders complying with ASTM C42/C42M or by other methods as directed by Architect.
 - 1) Acceptance criteria for concrete strength to be in accordance with ACI 301 (ACI 301M), Section 1.6.6.3.
 12. Additional testing and inspecting, at Contractor's expense, will be performed to determine compliance of replaced or additional work with specified requirements.
 13. Correct deficiencies in the Work that test reports and inspections indicate do not comply with the Contract Documents.

END OF SECTION 033000

SECTION 051200 - STRUCTURAL STEEL FRAMING

PART 1 - GENERAL

1.1 SECTION REQUIREMENTS

- A. Submittals: [Shop Drawings].
- B. Comply with AISC's "Specification for Structural Steel Buildings," RCSC's "Specification for Structural Joints Using ASTM A 325 or A 490 Bolts," and AWS D1.1/D1.1M, "Structural Welding Code - Steel."

PART 2 - PRODUCTS

2.1 STRUCTURAL STEEL

- A. W-Shapes: [ASTM A 992/A 992M].
- B. Channels, Angles[, M] [, S]-Shapes: [ASTM A 36/A 36M].
- C. Plate and Bar: [ASTM A 36/A 36M].
- D. Cold-Formed Hollow Structural Sections: ASTM A 500, [Grade B], structural tubing.
- E. Steel Pipe: ASTM A 53, Type E or S, Grade B, standard weight (Schedule 40) unless otherwise indicated.

2.2 ACCESSORIES

- A. High-Strength Bolts, Nuts, and Washers: ASTM A 325 (ASTM A 325M), Type 1, heavy hex steel structural bolts; ASTM A 563 (ASTM A 563M) heavy hex carbon-steel nuts; and ASTM F 436 (ASTM F 436M) hardened carbon-steel washers.
- B. Anchor Rods: ASTM F 1554, Grade 36.
 - 1. Nuts: ASTM A 563 (ASTM A 563M) hex carbon steel.
 - 2. Plate Washers: ASTM A 36/A 36M carbon steel.
 - 3. Washers: ASTM F 436 (ASTM F 436M) hardened carbon steel.
- C. Primer: Fabricator's standard lead- and chromate-free, nonasphaltic, rust-inhibiting primer.
- D. Grout: ASTM C 1107, nonmetallic, shrinkage resistant, factory packaged.

2.3 FABRICATION

- A. Fabricate and assemble structural steel in shop to greatest extent possible. Fabricate according to AISC's "Code of Standard Practice for Steel Buildings and Bridges" and its "Specification for Structural Steel Buildings - Allowable Stress Design and Plastic Design."
- B. Shop Priming: Prepare surfaces according to SSPC-SP 2, "Hand Tool Cleaning" or SSPC-SP 3, "Power Tool Cleaning." Shop prime steel to a dry film thickness of at least 1.5 mils (0.038 mm). Do not prime surfaces to be embedded in concrete or mortar or to be field welded.

PART 3 - EXECUTION

3.1 ERECTION

- A. Set structural steel accurately in locations and to elevations indicated and according to AISC's "Code of Standard Practice for Steel Buildings and Bridges" and its "Specification for Structural Steel Buildings - Allowable Stress Design and Plastic Design."
- B. Base and Bearing Plates: Clean bearing surfaces of bond-reducing materials, and roughen surfaces prior to setting plates. Clean bottom surface of plates.
 - 1. Set base and bearing plates for structural members on wedges, shims, or setting nuts.
 - 2. Weld plate washers to top of base plate.
 - 3. Snug-tighten anchor rods after supported members have been positioned and plumbed. Cut off protruding wedges or shims flush with edge of plate before packing with grout.
 - 4. Promptly pack grout solidly between bearing surfaces so no voids remain. Neatly finish exposed surfaces; protect grout and allow it to cure.
- C. Align and adjust various members forming part of complete frame or structure before permanently fastening. Before assembly, clean bearing surfaces and other surfaces that will be in permanent contact with members. Perform necessary adjustments to compensate for discrepancies in elevations and alignment.
- D. Do not use thermal cutting during erection.
- E. High-Strength Bolts: Install high-strength bolts according to RCSC's "Specification for Structural Joints Using ASTM A 325 or A 490 Bolts" for type of bolt and type of joint specified.
 - 1. Joint Type: [Snug tightened].
- F. Weld Connections: Comply with AWS D1.1/D1.1M for welding procedure specifications, tolerances, appearance, and quality of welds and for methods used in correcting welding work.

END OF SECTION 051200

SECTION 052100 - STEEL JOIST FRAMING

PART 1 - GENERAL

1.1 SECTION REQUIREMENTS

- A. Submittals: Shop Drawings and manufacturer certificates certifying that joists comply with requirements.
- B. Manufacturer Qualifications: A manufacturer certified by SJI to manufacture joists complying with applicable standard specifications and load tables of SJI "Specifications."
- C. Comply with standard specifications in SJI's "Specifications" that are applicable to types of joists indicated.
- D. Welding: Qualify procedures and personnel according to AWS D1.1/D1.1M, "Structural Welding Code - Steel."

PART 2 - PRODUCTS

2.1 JOISTS AND ACCESSORIES

- A. Steel: Comply with SJI's "Specifications" for web and steel-angle chord members.
- B. Steel Bearing Plates: ASTM A 36/A 36M.
- C. Bolts, Nuts, and Washers: ASTM A 325 (ASTM A 325M), Type 1, high-strength heavy hex steel structural bolts, heavy hex carbon-steel nuts, and hardened carbon-steel washers.
- D. Primer: Comply with performance requirements in SSPC-Paint 15.
- E. Manufacture steel joists of type indicated according to "Standard Specifications for Open Web Steel Joists, K-Series" in SJI's "Specifications," with steel-angle top- and bottom-chord members.
- F. Manufacture joist girders according to "Standard Specifications for Joist Girders" in SJI's "Specifications," with steel-angle top- and bottom-chord members.
- G. Bridging: Provide bridging anchors and horizontal or diagonal bridging of material, size, and type required by SJI's "Specifications" for type of joist, chord size, spacing, and span. Furnish additional erection bridging if required for stability.
- H. Fabricate steel bearing plates with integral anchorages of sizes and thicknesses indicated.
- I. Shop Priming: Prepare surfaces according to SSPC-SP 2 or SSPC-SP 3. Apply 1 coat of shop primer to joists and joist accessories to provide a dry film thickness at least 1 mil (0.025 mm).

PART 3 - EXECUTION

3.1 INSTALLATION

- A. Install joists and accessories plumb, square, and true to line; securely fasten to supporting construction according to SJI's "Specifications" and joist manufacturer's written recommendations.
 - 1. Delay rigidly connecting bottom-chord extensions to columns or supports until dead loads have been applied.
- B. Field weld joists to supporting steel bearing plates and framework.
- C. Bolt joists to supporting steel framework using high-strength structural bolts.
 - 1. Comply with RCSC's "Specification for Structural Joints Using ASTM A 325 or ASTM A 490 Bolts" for high-strength structural bolt installation and tightening requirements.
- D. Install and connect bridging concurrently with joist erection, before construction loads are applied. Anchor ends of bridging lines at top and bottom chords if terminating at walls or beams.

END OF SECTION 052100

SECTION 053100 - STEEL DECKING

PART 1 - GENERAL

1.1 SECTION REQUIREMENTS

- A. Submittals: [Product Data].
- B. Comply with SDI Publication No. 30.
- C. Comply with AWS D1.3, "Structural Welding Code - Sheet Steel."

PART 2 - PRODUCTS

2.1 MATERIALS

- A. Galvanized Steel Sheet: ASTM A 653/A 653M, Structural Steel (SS), Grade 33 (Grade 230), [G60 (Z180)] zinc coating.

2.2 DECKING

- A. Roof Deck: Fabricate panels from [galvanized-] steel sheet, without top-flange stiffening grooves, to comply with the following:
 - 1. Deck Profile: [Type B], gauge 18.
 - 2. Profile Depth: [1-1/2 inches (38 mm)].

2.3 MISCELLANEOUS

- A. Accessories: Manufacturer's recommended roof deck accessory materials [and floor deck pour stops and closures]. Sheet metal accessories of same material and finish as deck.

PART 3 - EXECUTION

3.1 DECK INSTALLATION

- A. Place, adjust, align, and bear deck panels on structure. Do not stretch or contract side-lap interlocks.
- B. Place deck panels flat and square and [weld] to structure without warp or deflection.
- C. Cut, reinforce, and fit deck panels and accessories around openings and projections.

- D. Roof Deck Accessories: Install sump pans, sump plates, ridge and valley plates, finish strips, cover plates, end closures, and reinforcing channels. Weld to substrate.
- E. Floor Pour Stops and Girder Fillers: Weld pour stops and girder fillers to structure.
- F. Floor Deck Closures: Weld steel sheet closures to deck to provide tight-fitting closures at open ends of ribs and sides of decking. Weld cover plates at changes in direction of floor deck panels.
- G. Prepare and repair damaged galvanized coatings on both surfaces with galvanized repair paint according to ASTM A 780.
- H. Wire brush, clean, and paint scarred areas, welds, and rust spots on both surfaces of painted deck panels.

END OF SECTION 053100

SECTION 055111 - ALUMINUM LADDERS

PART 1 - GENERAL

1.1 SUMMARY

A. Section Includes:

1. Fixed vertical ladders.

1.2 REFERENCES

A. Occupational Safety and Health Administration of the United States (OSHA):

1. 1. OSHA 1910.23: Fixed Ladders.

1.3 ACTION SUBMITTALS

A. Product Data:

1. Manufacturer's data sheets indicating:
 - a. Preparation instructions and recommendations.
 - b. Storage and handling requirements and recommendations.
 - c. Installation methods..

B. Shop Drawings:

1. Include plans, elevations, sections, and mounting attachment details.
2. Include diagrams for of ladders to other construction and methods of anchorage.

1.4 QUALITY ASSURANCE

A. Qualifications:

1. Manufacturer: All primary products specified in this section will be supplied by a single manufacturer with a minimum of ten years' experience.

1.5 WARRANTY

1. Warranty Period:At project closeout, submit an executed copy of the manufacturer's five year standard limited warranty against manufacturing defect, outlining its terms, conditions, and exclusions from coverage.

PART 2 - PRODUCTS

2.1 STANDARD ACCESS LADDERS

- A. Modular Vertical Aluminum Fixed Ladder for safe access to elevated areas. Ladder fall arrest system required on all heights 24ft (7320 mm) or greater.
 - 1. Provide assembled ladders that comply with OSHA and local building codes, with all edges rounded, clean, smooth, and burr free.
 - 2. At Top of Ladders Leading to Roofs or Landings: Extending minimum of 42 inches (1067 mm) vertically above top of parapet or landing and extending minimum of 10 inches (254 mm) past edge of roof or landing; with free walk-through onto roof/landing
- B. Material: High tensile 6106-T6 aluminum, mill finish.
- C. Ladder Height: Fall protection required over 24 ft (7320 mm).
- D. Ladder Width: 23-1/2 inches (597 mm). Walk-Through Width: 24 inches (610 mm)
- E. Capacity: Unit shall support a 1000 lbs (453.6 kg) loading without failure, and individual treads shall withstand a 1000 lbs (453.6 kg) loading without failure.
- F. Performance Standard: Units designed and manufactured to meet or exceed OSHA 1910.23.

PART 3 - EXECUTION

3.1 INSTALLATION

- A. Install in accordance with manufacturer's instructions.
- B. Anchor securely using fasteners specified by manufacturer or others of equivalent or greater strength and corrosion resistance.

END OF SECTION 055111

SECTION 055116 - METAL FLOOR PLATE STAIRS

PART 1 - GENERAL

1.1 SUMMARY

A. Section Includes:

1. Industrial Class stairs with steel floor plate treads.
2. Steel railings and guards attached to metal stairs.
3. Steel handrails attached to walls adjacent to metal stairs.

1.2 COORDINATION

- A. Coordinate selection of shop primers with topcoats to be applied over them. Comply with paint and coating manufacturers' written instructions to ensure that shop primers and topcoats are compatible with one another.

1.3 ACTION SUBMITTALS

A. Product Data: For metal floor plate stairs and the following:

1. Metal floor plate treads.
2. Woven-wire mesh.
3. Welded-wire mesh.
4. Shop primer products.
5. Grout.

B. Shop Drawings:

1. Include plans, elevations, sections, details, and attachments to other work.
2. Indicate sizes of metal sections, thickness of metals, profiles, holes, and field joints.
3. Include plan at each level.
4. Indicate locations of anchors, weld plates, and blocking for attachment of wall-mounted handrails.

- C. Delegated Design Submittal: For stairs, railings, and guards, including analysis data signed and sealed by the qualified professional engineer responsible for their preparation.

1.4 INFORMATIONAL SUBMITTALS

- A. Qualification Data: For professional engineer's experience with providing delegated design engineering services of the kind indicated, including documentation that engineer is licensed in the jurisdiction of Puerto Rico in which Project is located.

- B. Welding certificates.

1.5 QUALITY ASSURANCE

- A. Welding Qualifications: Qualify procedures and personnel according to AWS D1.1/D1.1M, "Structural Welding Code - Steel."

PART 2 - PRODUCTS

2.1 PERFORMANCE REQUIREMENTS

- A. Delegated Design: Engage a qualified professional engineer, as defined in Section 014000 "Quality Requirements," to design stairs, railings, and guards, including attachment to building construction.
- B. Structural Performance of Stairs: Metal stairs withstand the effects of gravity loads and the following loads and stresses within limits and under conditions indicated:
 1. Uniform Load: 100 lbf/sq. ft. (4.79 kN/sq. m).
 2. Concentrated Load: 300 lbf (1.33 kN) applied on an area of 2 inches by 2 inches. (2580 sq. mm).
 3. Uniform and concentrated loads need not be assumed to act concurrently.
 4. Stair Framing: Capable of withstanding stresses resulting from railing and guard loads in addition to loads specified above.
 5. Limit deflection of treads, platforms, and framing members to L/360.
- C. Structural Performance of Railings and Guards: Railings and guards, including attachment to building construction, withstand the effects of gravity loads and the following loads and stresses within limits and under conditions indicated:
 1. Handrails and Top Rails of Guards:
 - a. Uniform load of 50 lbf/ft. (0.73 kN/m) applied in any direction.
 - b. Concentrated load of 200 lbf (0.89 kN) applied in any direction.
 - c. Uniform and concentrated loads need not be assumed to act concurrently.
 2. Infill of Guards:
 - a. Concentrated load of 50 lbf (0.22 kN) applied horizontally on an area of 1 sq. ft. (0.093 sq. m).
 - b. Infill load and other loads need not be assumed to act concurrently.
 3. Thermal Movements: Allow for thermal movements from ambient and surface temperature changes.
 - a. Temperature Change: $\Delta T = 20$ deg F (6.67 deg C).
- D. Seismic Performance of Stairs: Metal stairs withstand the effects of earthquake motions determined according to ASCE/SEI 7, Chapter 13.
 1. Component Importance Factor: 1.5.

2. Seismic coefficients shall be obtained from Table 13.5-1: Coefficients for Architectural Components.

2.2 METALS

- A. Steel Plates, Shapes, and Bars: ASTM A36/A36M.
- B. Rolled-Steel Floor Plate: ASTM A786/A786M, rolled from plate complying with ASTM A36/A36M or ASTM A283/A283M, Grade C or D.
- C. Steel Pipe for Railings and Guards: ASTM A53/A53M, Type F or Type S, Grade A, Standard Weight (Schedule 40), unless another grade and weight are required by structural loads.
 1. Provide galvanized finish for exterior installations and where indicated.
- D. Welded-Wire Mesh: Diamond pattern, 2-inch (50-mm) welded-wire mesh, made from 0.236-inch (6.0-mm) nominal-diameter steel wire complying with ASTM A510/A510M.
- E. Cast Iron: Either gray iron, ASTM A48/A48M, or malleable iron, ASTM A47/A47M, unless otherwise indicated.

2.3 FASTENERS

- A. General: Provide zinc-plated fasteners with coating complying with ASTM B633 or ASTM F1941/F1941M, Class Fe/Zn 12 for exterior use, and Class Fe/Zn 5 where built into exterior walls.
 1. Select fasteners for type, grade, and class required.
- B. Fasteners for Anchoring Railings and Guards to Other Construction: Select fasteners of type, grade, and class required to produce connections suitable for anchoring railings and guards to other types of construction indicated and capable of withstanding design loads.
- C. Post-Installed Anchors: Torque-controlled expansion anchors capable of sustaining, without failure, a load equal to six times the load imposed when installed in unit masonry and four times the load imposed when installed in concrete, as determined by testing according to ASTM E488/E488M, conducted by a qualified independent testing agency.
 1. Material for Exterior Locations and Where Stainless Steel Is Indicated: Alloy Group 1 (A1) stainless steel bolts, ASTM F593, and nuts, ASTM F594 (ASTM F836M).

2.4 MISCELLANEOUS MATERIALS

- A. Shop Primers: Provide primers that comply with Section 099113 "Exterior Painting" and Section 099123 "Interior Painting."
- B. Universal Shop Primer: Fast-curing, lead- and chromate-free, universal modified-alkyd primer complying with MPI#79 and compatible with topcoat.
 1. Use primer containing pigments that make it easily distinguishable from zinc-rich primer.

- C. Zinc-Rich Primer: Comply with SSPC-Paint 20, Type II, Level 2, and compatible with topcoat.
- D. Shop Primer for Galvanized Steel: Primer formulated for exterior use over zinc-coated metal and compatible with finish paint systems indicated.
- E. Galvanizing Repair Paint: High-zinc-dust-content paint complying with ASTM A780/A780M and compatible with paints specified to be used over it.
- F. Nonmetallic, Shrinkage-Resistant Grout: ASTM C1107/C1107M, factory-packaged, nonmetallic aggregate grout; recommended by manufacturer for exterior use; noncorrosive and nonstaining; mixed with water to consistency suitable for application and a 30-minute working time.

2.5 FABRICATION, GENERAL

- A. Provide complete stair assemblies, including metal framing, hangers, railings, guards, clips, brackets, bearing plates, and other components necessary to support and anchor stairs and platforms on supporting structure.
 - 1. Join components by welding unless otherwise indicated.
 - 2. Use connections that maintain structural value of joined pieces.
- B. Assemble stairs, railings, and guards in shop to greatest extent possible.
 - 1. Disassemble units only as necessary for shipping and handling limitations.
 - 2. Clearly mark units for reassembly and coordinated installation.
- C. Cut, drill, and punch metals cleanly and accurately.
 - 1. Remove burrs and ease edges to a radius of approximately **1/32 inch (1 mm)** unless otherwise indicated.
 - 2. Remove sharp or rough areas on exposed surfaces.
- D. Form bent-metal corners to smallest radius possible without causing grain separation or otherwise impairing work.
- E. Form exposed work with accurate angles and surfaces and straight edges.
- F. Weld connections to comply with the following:
 - 1. Use materials and methods that minimize distortion and develop strength and corrosion resistance of base metals.
 - 2. Obtain fusion without undercut or overlap.
 - 3. Remove welding flux immediately.
 - 4. Weld exposed corners and seams continuously unless otherwise indicated.
 - 5. At exposed connections, finish exposed welds to comply with NOMMA's "Voluntary Joint Finish Standards" for Finish #4 - Good quality, uniform undressed weld with minimal splatter.
- G. Form exposed connections with hairline joints, flush and smooth, using concealed fasteners where possible.

1. Where exposed fasteners are required, use Phillips flat-head (countersunk) screws or bolts unless otherwise indicated.
2. Locate joints where least conspicuous.
3. Fabricate joints that will be exposed to weather in a manner to exclude water.
4. Provide weep holes where water may accumulate internally.

2.6 FABRICATION OF STEEL-FRAMED STAIRS

- A. NAAMM Stair Standard: Comply with NAAMM AMP 510, "Metal Stairs Manual," for Industrial Class, unless more stringent requirements are indicated.
- B. Stair Framing:
 1. Fabricate stringers of steel plates or channels.
 - a. Stringer Size: As indicated on Drawings (Delegated Design).
 - b. Provide closures for exposed ends of channel stringers.
 - c. Finish: Shop primed.
 2. Construct platforms and tread supports of steel plate or channel headers and miscellaneous framing members as indicated on Drawings (Delegated Design).
 - a. Provide closures for exposed ends of channel framing.
 - b. Finish: Shop primed.
 3. Weld stringers to headers; weld framing members to stringers and headers.
 4. Where masonry walls support metal stairs, provide temporary supporting struts designed for erecting steel stair components before installing masonry.
- C. Metal Floor Plate Stairs: Form treads and platforms to configurations shown from rolled-steel floor plate of thickness indicated on Drawings.
 1. Form treads with integral nosing and back edge stiffener. Form risers of same material as treads.
 2. Weld steel supporting brackets to stringers and weld treads to brackets.
 3. Fabricate platforms with integral nosings matching treads and weld to platform framing.
 4. Fabricate treads and platforms of exterior stairs so finished walking surfaces slope to drain.
- D. Risers: Open.
- E. Toe Plates: Provide toe plates around openings and at edge of open-sided floors and platforms, and at open ends and open back edges of treads.
 1. Material and Finish: Match treads and platforms.
 2. Fabricate to dimensions and details indicated.

2.7 FABRICATION OF STAIR RAILINGS AND GUARDS

- A. Fabricate railings and guards to comply with requirements indicated for design, dimensions, details, finish, and member sizes, including wall thickness of member, post spacings, wall bracket spacing, and anchorage, but not less than that needed to withstand indicated loads.
1. Rails and Posts: **1-5/8-inch- (41-mm-)** diameter top and bottom rails and **1-1/2-inch- (38-mm-)** square posts.
 2. Intermediate Rails Infill: **1-5/8-inch- (41-mm-)** diameter intermediate rails spaced less than **12 inches (305 mm)** clear.
- B. Welded Connections: Fabricate railings and guards with welded connections.
1. Fabricate connections that are exposed to weather in a manner that excludes water.
 - a. Provide weep holes where water may accumulate internally.
 2. Cope components at connections to provide close fit, or use fittings designed for this purpose.
 3. Weld all around at connections, including at fittings.
 4. Use materials and methods that minimize distortion and develop strength and corrosion resistance of base metals.
 5. Obtain fusion without undercut or overlap.
 6. Remove flux immediately.
 7. Finish welds to comply with NOMMA's "Voluntary Joint Finish Standards" for Finish #4 - Good quality, uniform undressed weld with minimal splatter as shown in NAAMM AMP 521.
- C. Form changes in direction of railings and guards as follows:
1. By bending.
- D. For changes in direction made by bending, use jigs to produce uniform curvature for each repetitive configuration required.
1. Maintain cross section of member throughout entire bend without buckling, twisting, cracking, or otherwise deforming exposed surfaces of components.
- E. Close exposed ends of railing and guard members with prefabricated end fittings.
- F. Provide wall returns at ends of wall-mounted handrails unless otherwise indicated.
1. Close ends of returns unless clearance between end of rail and wall is **1/4 inch (6 mm)** or less.
- G. Connect posts to stair framing by direct welding unless otherwise indicated.
- H. Brackets, Flanges, Fittings, and Anchors: Provide wall brackets, end closures, flanges, miscellaneous fittings, and anchors for interconnecting components and for attaching to other work.
1. Furnish inserts and other anchorage devices for connecting to concrete or masonry work.

2. For galvanized railings and guards, provide galvanized fittings, brackets, fasteners, sleeves, and other ferrous-metal components.
3. For nongalvanized railings and guards, provide nongalvanized ferrous-metal fittings, brackets, fasteners, and sleeves, except galvanize anchors embedded in exterior masonry and concrete construction.
4. Provide type of bracket with predrilled hole for exposed bolt anchorage and that provides **1-1/2-inch (38-mm)** clearance from inside face of handrail to finished wall surface.

2.8 FINISHES

- A. Finish metal stairs after assembly.
- B. Galvanizing: Hot-dip galvanize items as indicated to comply with ASTM A153/A153M for steel and iron hardware and with ASTM A123/A123M for other steel and iron products.
 1. Do not quench or apply post-galvanizing treatments that might interfere with paint adhesion.
 2. Fill vent and drain holes that will be exposed in finished Work, unless indicated to remain as weep holes, by plugging with zinc solder and filing off smooth.
- C. Preparation for Shop Priming: Prepare uncoated ferrous-metal surfaces to comply with SSPC-SP 6/NACE No. 3, "Commercial Blast Cleaning."
 1. Exterior Stairs: SSPC-SP 6/NACE No. 3, "Commercial Blast Cleaning."
 2. Interior Stairs: SSPC-SP 3, "Power Tool Cleaning."
- D. Apply shop primer to uncoated surfaces of metal stair components, except those with galvanized finishes and those to be embedded in concrete or masonry unless otherwise indicated. Comply with SSPC-PA 1, "Paint Application Specification No. 1: Shop, Field, and Maintenance Painting of Steel," for shop painting.
 1. Stripe paint corners, crevices, bolts, welds, and sharp edges.

PART 3 - EXECUTION

3.1 INSTALLATION OF METAL STAIRS

- A. Fastening to In-Place Construction: Provide anchorage devices and fasteners where necessary for securing metal stairs to in-place construction.
 1. Include threaded fasteners for concrete and masonry inserts, through-bolts, lag bolts, and other connectors.
- B. Cutting, Fitting, and Placement: Perform cutting, drilling, and fitting required for installing metal stairs. Set units accurately in location, alignment, and elevation, measured from established lines and levels and free of rack.
- C. Install metal stairs by welding stair framing to steel structure or to weld plates cast into concrete unless otherwise indicated.

1. Grouted Baseplates: Clean concrete and masonry bearing surfaces of bond-reducing materials, and roughen to improve bond to surfaces.
 - a. Clean bottom surface of baseplates.
 - b. Set steel stair baseplates on wedges, shims, or leveling nuts.
 - c. After stairs have been positioned and aligned, tighten anchor bolts.
 - d. Do not remove wedges or shims but, if protruding, cut off flush with edge of bearing plate before packing with grout.
 - e. Promptly pack grout solidly between bearing surfaces and plates to ensure that no voids remain.
 - 1) Neatly finish exposed surfaces; protect grout and allow to cure.
 - 2) Comply with manufacturer's written installation instructions for shrinkage-resistant grouts.
- D. Provide temporary bracing or anchors in formwork for items that are to be built into concrete, masonry, or similar construction.
- E. Fit exposed connections accurately together to form hairline joints.
 1. Weld connections that are not to be left as exposed joints but cannot be shop welded because of shipping size limitations.
 2. Do not weld, cut, or abrade surfaces of exterior units that have been hot-dip galvanized after fabrication and are for bolted or screwed field connections.
 3. Comply with requirements for welding in "Fabrication, General" Article.

3.2 INSTALLATION OF RAILINGS AND GUARDS

- A. Adjust railing and guard systems before anchoring to ensure matching alignment at abutting joints with tight, hairline joints.
 1. Space posts at spacing indicated or, if not indicated, as required by design loads.
 2. Plumb posts in each direction, within a tolerance of **1/16 inch in 3 feet (2 mm in 1 m)**.
 3. Align rails and guards so variations from level for horizontal members and variations from parallel with rake of stairs for sloping members do not exceed **1/4 inch in 12 feet (6 mm in 3.5 m)**.
 4. Secure posts, rail ends, and guard ends to building construction as follows:
 - a. Anchor posts to steel by welding to steel supporting members.
 - b. Anchor handrail and guard ends to concrete and masonry with steel round flanges welded to rail and guard ends and anchored with post-installed anchors and bolts.
- B. Attach handrails to wall with wall brackets.
 1. Locate brackets as indicated or, if not indicated, at spacing required to support structural loads.
 2. Secure wall brackets to building construction as required to comply with performance requirements.

3.3 REPAIR

- A. Touchup Painting: Immediately after erection, clean field welds, bolted connections, and abraded areas of shop paint, and paint exposed areas with same material as used for shop painting to comply with SSPC-PA 1 for touching up shop-painted surfaces.
 - 1. Apply by brush or spray to provide a minimum **2.0-mil (0.05-mm)** dry film thickness.
- B. Galvanized Surfaces: Clean field welds, bolted connections, and abraded areas and repair galvanizing to comply with ASTM A780/A780M.

END OF SECTION 055116

SECTION 055213 - PIPE AND TUBE RAILINGS

PART 1 - GENERAL

1.1 SUMMARY

A. Section Includes:

1. Steel railings.

1.2 ACTION SUBMITTALS

A. Product Data:

1. Manufacturer's product lines of mechanically connected railings.
2. Handrail brackets.
3. Shop primer.
4. Intermediate coats and topcoats.
5. Bituminous paint.
6. Nonshrink, nonmetallic grout.
7. Anchoring cement.
8. Metal finishes.
9. Paint products.

B. Shop Drawings: Include plans, elevations, sections, details, and attachments to other work.

C. Samples: For each type of exposed finish.

D. Delegated Design Submittal: For railings, including analysis data signed and sealed by the qualified professional engineer responsible for their preparation.

1.3 INFORMATIONAL SUBMITTALS

A. Qualification Data: For delegated design professional engineer or testing agency.

B. Welding certificates.

C. Product Test Reports: For tests on railings performed by a qualified testing agency, in accordance with ASTM E894 and ASTM E935.

1.4 QUALITY ASSURANCE

A. Welding Qualifications: Qualify procedures and personnel in accordance with the following:

1. AWS D1.1/D1.1M, "Structural Welding Code - Steel."

PART 2 - PRODUCTS

2.1 PERFORMANCE REQUIREMENTS

- A. Delegated Design: Engage a qualified professional engineer, as defined in Section 014000 "Quality Requirements," to design railings, including attachment to building construction.
- B. Structural Performance: Railings, including attachment to building construction, withstand the effects of gravity loads and the following loads and stresses within limits and under conditions indicated:
 - 1. Handrails and Top Rails of Guards:
 - a. Uniform load of 50 lbf/ ft. (0.73 kN/m) applied in any direction.
 - b. Concentrated load of 200 lbf (0.89 kN) applied in any direction.
 - c. Uniform and concentrated loads need not be assumed to act concurrently.

2.2 METALS, GENERAL

- A. Metal Surfaces, General: Provide materials with smooth surfaces, without seam marks, roller marks, rolled trade names, stains, discolorations, or blemishes.
- B. Brackets, Flanges, and Anchors: Cast or formed metal of same type of material and finish as supported rails unless otherwise indicated.
 - 1. Provide type of bracket with flange tapped for concealed anchorage to threaded hanger bolt and that provides 1-1/2-inch (38-mm) clearance from inside face of handrail to finished wall surface.

2.3 STEEL RAILINGS

- A. Tubing: .
- B. Pipe: ASTM A53/A53M, Type F or Type S, Grade A, Standard Weight (Schedule 40), unless another grade and weight are required by structural loads.
 - 1. Provide galvanized finish for exterior installations and where indicated.
- C. Plates, Shapes, and Bars: ASTM A36/A36M.
- D. Cast Iron Fittings: Either gray iron, ASTM A48/A48M, or malleable iron, ASTM A47/A47M, unless otherwise indicated.

2.4 FASTENERS

- A. Fastener Materials:

1. Hot-Dip Galvanized Railing Components: Type 304 stainless steel or hot-dip zinc-coated steel fasteners complying with ASTM A153/A153M or ASTM F2329/F2329M for zinc coating.

2.5 MISCELLANEOUS MATERIALS

- A. Welding Rods and Bare Electrodes: Select in accordance with AWS specifications for metal alloy welded.
- B. Etching Cleaner for Galvanized Metal: Complying with MPI#25.
- C. Galvanizing Repair Paint: High-zinc-dust-content paint, complying with SSPC-Paint 20 and compatible with paints specified to be used over it.
- D. Shop Primers: Provide primers that comply with Section 099113 "Exterior Painting".
- E. Universal Shop Primer: Fast-curing, lead- and chromate-free, universal modified-alkyd primer complying with MPI#79 and compatible with topcoat.
 1. Use primer containing pigments that make it easily distinguishable from zinc-rich primer.
- F. Shop Primer for Galvanized Steel: Primer formulated for exterior use over zinc-coated metal and compatible with finish paint systems indicated.
- G. Intermediate Coats and Topcoats: Provide products that comply with Section 099113 "Exterior Painting."
- H. Nonshrink, Nonmetallic Grout: Factory-packaged, nonstaining, noncorrosive, nongaseous grout, complying with ASTM C1107/C1107M. Provide grout specifically recommended by manufacturer for interior and exterior applications.
- I. Anchoring Cement: Factory-packaged, nonshrink, nonstaining, hydraulic-controlled expansion cement formulation for mixing with water at Project site to create pourable anchoring, patching, and grouting compound.
 1. Water-Resistant Product: At exterior locations and where indicated on Drawings, provide formulation that is resistant to erosion from water exposure without needing protection by a sealer or waterproof coating and that is recommended by manufacturer for exterior use.

2.6 FABRICATION

- A. Cut, drill, and punch metals cleanly and accurately.
 1. Remove burrs and ease edges to a radius of approximately $1/32$ inch (1 mm) unless otherwise indicated.
 2. Remove sharp or rough areas on exposed surfaces.
- B. Form work true to line and level with accurate angles and surfaces.

- C. Welded Connections: Cope components at connections to provide close fit, or use fittings designed for this purpose. Weld all around at connections, including at fittings.
 - 1. Use materials and methods that minimize distortion and develop strength and corrosion resistance of base metals.
 - 2. Obtain fusion without undercut or overlap.
 - 3. Remove flux immediately.
- D. Nonwelded Connections: Connect members with concealed mechanical fasteners and fittings. Fabricate members and fittings to produce flush, smooth, rigid, hairline joints.
- E. Form changes in direction as follows:
 - 1. As detailed.
- F. Close exposed ends of hollow railing members with prefabricated cap and end fittings of same metal and finish as railings.
- G. Brackets, Flanges, Fittings, and Anchors: Provide wall brackets, flanges, miscellaneous fittings, and anchors to interconnect railing members to other work unless otherwise indicated.
- H. Provide inserts and other anchorage devices for connecting railings to concrete or masonry work.
 - 1. Fabricate anchorage devices capable of withstanding loads imposed by railings.
 - 2. Coordinate anchorage devices with supporting structure.
- I. For railing posts set in concrete, provide stainless steel sleeves not less than **6 inches (150 mm)** long with inside dimensions not less than **1/2 inch (13 mm)** greater than outside dimensions of post, with metal plate forming bottom closure.
- J. For removable railing posts, fabricate slip-fit sockets from stainless steel tube or pipe whose ID is sized for a close fit with posts; limit movement of post without lateral load, measured at top, to not more than one-fortieth of post height.
 - 1. Provide socket covers designed and fabricated to resist being dislodged.
 - 2. Provide chain with eye, snap hook, and staple across gaps formed by removable railing sections at locations indicated. Fabricate from same metal as railings.

2.7 STEEL AND IRON FINISHES

- A. Galvanized Railings:
 - 1. Hot-dip galvanize exterior steel railings, including hardware, after fabrication.
 - 2. Comply with ASTM A123/A123M for hot-dip galvanized railings.
 - 3. Comply with ASTM A153/A153M for hot-dip galvanized hardware.
- B. For galvanized railings, provide hot-dip galvanized fittings, brackets, fasteners, sleeves, and other ferrous components.

- C. Preparing Galvanized Railings for Shop Priming: After galvanizing, thoroughly clean railings of grease, dirt, oil, flux, and other foreign matter, and treat with etching cleaner.
 - 1. Comply with SSPC-SP 16.
- D. Primer Application: Apply shop primer to prepared surfaces of railings unless otherwise indicated. Comply with requirements in SSPC-PA 1 for shop painting. Primer need not be applied to surfaces to be embedded in concrete or masonry.
 - 1. Shop prime uncoated railings with primers specified in Section 099113 "Exterior Painting" and Section 099123 "Interior Painting" unless indicated.
- E. Shop-Painted Finish: Comply with Section 099113 "Exterior Painting."
 - 1. Color: As selected by Architect from manufacturer's full range.

PART 3 - EXECUTION

3.1 INSTALLATION, GENERAL

- A. Perform cutting, drilling, and fitting required for installing railings.
 - 1. Fit exposed connections together to form tight, hairline joints.
 - 2. Install railings level, plumb, square, true to line; without distortion, warp, or rack.
 - 3. Set railings accurately in location, alignment, and elevation; measured from established lines and levels.
 - 4. Do not weld, cut, or abrade surfaces of railing components that are coated or finished after fabrication and that are intended for field connection by mechanical or other means without further cutting or fitting.
 - 5. Set posts plumb within a tolerance of **1/16 inch in 3 feet (2 mm in 1 m)**.
 - 6. Align rails so variations from level for horizontal members and variations from parallel with rake of steps and ramps for sloping members do not exceed **1/4 inch in 12 feet (6 mm in 3.5 m)**.
- B. Control of Corrosion: Prevent galvanic action and other forms of corrosion by insulating metals and other materials from direct contact with incompatible materials.
 - 1. Coat concealed surfaces of aluminum that will be in contact with grout, concrete, masonry, wood, or dissimilar metals, with a heavy coat of bituminous paint.

3.2 ANCHORING POSTS

- A. Form or core-drill holes not less than **5 inches (125 mm)** deep and **3/4 inch (20 mm)** larger than OD of post for installing posts in concrete. Clean holes of loose material, insert posts, and fill annular space between post and concrete with nonshrink, nonmetallic grout or anchoring cement, mixed and placed to comply with anchoring material manufacturer's written instructions.

3.3 ATTACHING RAILINGS

- A. Attach handrails to walls with wall brackets, except where end flanges are used. Provide brackets with 1-1/2-inch (38-mm) clearance from inside face of handrail and finished wall surface.
- B. Secure wall brackets and railing end flanges to building construction as follows:
 - 1. For concrete and solid masonry anchorage, use drilled-in expansion shields and hanger or lag bolts.
 - 2. For hollow masonry anchorage, use toggle bolts.
- C. Install railing gates level, plumb, and secure for full opening without interference.
- D. Touchup Painting:
 - 1. Immediately after erection, clean field welds, bolted connections, and abraded areas of shop paint, and paint exposed areas with the same material used for shop painting to comply with SSPC-PA 1 for touching up shop-painted surfaces.

3.4 CLEANING

- A. Clean by washing thoroughly with clean water and soap and rinsing with clean water.
- B. Galvanized Surfaces: Clean field welds, bolted connections, and abraded areas, and repair galvanizing to comply with ASTM A780/A780M.

END OF SECTION 055213

SECTION 070150.19 - PREPARATION FOR REROOFING

PART 1 - GENERAL

1.1 SUMMARY

A. Section Includes:

1. Full tear-off of roof system at areas indicated on Drawings.
2. Partial tear-off of roof areas indicated on Drawings.
3. Re-cover preparation of roof areas indicated on Drawings.
4. Removal of flashings and counterflashings.

1.2 PREINSTALLATION MEETINGS

- A. Preliminary Roofing Conference: Before starting removal Work, conduct conference at Project site.

1.3 INFORMATIONAL SUBMITTALS

- A. Photographs or Videotape: Show existing conditions of adjoining construction and site improvements, including exterior and interior finish surfaces, that might be misconstrued as having been damaged by reroofing operations.
1. Submit before Work begins.

1.4 QUALITY ASSURANCE

- A. Installer Qualifications: Approved by warrantor of existing roofing system to work on existing roofing.

1.5 FIELD CONDITIONS

- A. Existing Roofing System: SBS-modified bituminous roofing.
- B. Owner will occupy portions of building immediately below reroofing area.
1. Conduct reroofing so Owner's operations are not disrupted.
 2. Provide Owner with not less than 72 hours' written notice of activities that may affect Owner's operations.
 3. Coordinate work activities daily with Owner so Owner has adequate advance notice to place protective dust and water-leakage covers over sensitive equipment and furnishings, shut down HVAC and fire-alarm or -detection equipment if needed, and evacuate occupants from below work area.

4. Before working over structurally impaired areas of deck, notify Owner to evacuate occupants from below affected area.
 - a. Verify that occupants below work area have been evacuated before proceeding with work over impaired deck area.
- C. Protect building to be reroofed, adjacent buildings, walkways, site improvements, exterior plantings, and landscaping from damage or soiling from reroofing operations.
- D. Maintain access to existing walkways, corridors, and other adjacent occupied or used facilities.
- E. Conditions existing at time of inspection for bidding will be maintained by Owner as far as practical.
 1. Construction Drawings and Project Manual for existing roofing system are provided for Contractor's convenience and information, but they are not a warranty of existing conditions. They are intended to supplement rather than serve in lieu of Contractor's own investigations. Contractor is responsible for conclusions derived from existing documents.
- F. Weather Limitations: Proceed with reroofing preparation only when existing and forecasted weather conditions permit Work to proceed without water entering existing roofing system or building.
 1. Remove only as much roofing in one day as can be made watertight in the same day.

1.6 WARRANTY

- A. Existing Warranties: Remove, replace, patch, and repair materials and surfaces cut or damaged during reroofing, by methods and with materials so as not to void existing roofing system warranty issued.

PART 2 - PRODUCTS

2.1 AUXILIARY REROOFING MATERIALS

- A. General: Use auxiliary reroofing preparation materials recommended by roofing system manufacturer for intended use and compatible with components of existing and new roofing system.

PART 3 - EXECUTION

3.1 PREPARATION

- A. Seal or isolate windows that may be exposed to airborne substances created in removal of existing materials.
- B. Shut off rooftop utilities and service piping before beginning the Work.

- C. Test existing roof drains to verify that they are not blocked or restricted.
 - 1. Immediately notify Architect of any blockages or restrictions.
- D. Coordinate with Owner to shut down air-intake equipment in the vicinity of the Work.
 - 1. Cover air-intake louvers before proceeding with reroofing work that could affect indoor air quality or activate smoke detectors in the ductwork.
- E. During removal operations, have sufficient and suitable materials on-site to facilitate rapid installation of temporary protection in the event of unexpected rain.
- F. Maintain roof drains in functioning condition to ensure roof drainage at end of each workday.
 - 1. Prevent debris from entering or blocking roof drains and conductors.
 - a. Use roof-drain plugs specifically designed for this purpose.
 - b. Remove roof-drain plugs at end of each workday, when no work is taking place, or when rain is forecast.
 - 2. If roof drains are temporarily blocked or unserviceable due to roofing system removal or partial installation of new roofing system, provide alternative drainage method to remove water and eliminate ponding.
 - a. Do not permit water to enter into or under existing roofing system components that are to remain.

3.2 ROOF TEAR-OFF

- A. Lower removed roofing materials to ground and onto lower roof levels, using dust-tight chutes or other acceptable means of removing materials from roof areas.
- B. Remove pavers and accessories from roofing.
 - 1. Store and protect accessories for reuse in manner not to exceed structural loading limitations of roof deck.
- C. Full Roof Tear-off: Where indicated on Drawings, remove existing roofing and other roofing system components down to the existing concrete fill.
 - 1. Remove substrate board vapor retarder roof insulation and cover board.
 - 2. Remove base flashings and counter flashings.
 - 3. Remove perimeter edge flashing and gravel stops.
 - 4. Remove copings.
 - 5. Remove expansion-joint covers.
 - 6. Remove flashings at pipes, curbs, mechanical equipment, and other penetrations.
 - 7. Remove roof drains indicated on Drawings to be removed.
 - 8. Remove wood blocking, curbs, and nailers.
 - 9. Bitumen and felts that are firmly bonded to concrete decks are permitted to remain if felts are dry.

- a. Remove unadhered bitumen, unadhered felts, and wet felts.
10. Remove fasteners from deck or cut fasteners off slightly above deck surface.
- D. Partial Roof Tear-off: Where indicated on Drawings, remove existing roofing down to existing insulation and immediately check for presence of moisture.
 1. Remove wet or damp materials below existing roofing and above deck as directed by Architect.
 2. Inspect wood blocking, curbs, and nailers for deterioration and damage.
 - a. If wood blocking, curbs, or nailers have deteriorated, immediately notify Architect.
 3. Bitumen and felts that are firmly bonded to concrete decks are permitted to remain if felts are dry.
 - a. Remove unadhered bitumen, unadhered felts, and wet felts.
 4. Remove fasteners from deck or cut fasteners off slightly above deck surface.

3.3 DECK PREPARATION

- A. Inspect deck after tear-off of roofing system.
- B. If broken or loose fasteners that secure deck panels to one another or to structure are observed, or if deck appears or feels inadequately attached, immediately notify Architect.
 1. Do not proceed with installation until directed by Architect.
- C. If deck surface is unsuitable for receiving new roofing or if structural integrity of deck is suspect, immediately notify Architect.
 1. Do not proceed with installation until directed by Architect.
- D. Replace steel deck as indicated on Drawings.

3.4 ROOF RE-COVER PREPARATION

- A. Remove blisters, ridges, buckles, mechanically attached roofing fastener buttons projecting above roofing, and other substrate irregularities from existing roofing that inhibit new recover boards from conforming to substrate.
 1. Broom clean existing substrate.
 2. Remove materials that are wet or damp.

3.5 BASE FLASHING REMOVAL

- A. Remove existing base flashings.

1. Clean substrates of contaminants, such as asphalt, sheet materials, dirt, and debris.
- B. Do not damage metal counterflashings that are to remain.
 1. Replace metal counterflashings damaged during removal with counterflashings of same metal, weight or thickness, and finish as existing.
- C. Inspect parapet sheathing, wood blocking, curbs, and nailers for deterioration and damage.
 1. If parapet sheathing, wood blocking, curbs, or nailers have deteriorated, immediately notify Architect.
- D. Remove existing parapet sheathing and replace with new parapet sheathing to comply with Section 061600 "Sheathing."
 1. If parapet framing, wood blocking, curbs, or nailers have deteriorated, immediately notify Architect.
- E. When directed by Architect, replace parapet framing, wood blocking, curbs, and nailers.

END OF SECTION 070150.19

SECTION 074646 - FIBER-CEMENT SIDING

PART 1 - GENERAL

1.1 SUMMARY

- A. Section includes fiber-cement soffit.

1.2 ACTION SUBMITTALS

- A. Product Data: For each type of product.
- B. Samples: For fiber-cement soffit including related accessories.

1.3 INFORMATIONAL SUBMITTALS

- A. Product certificates.
- B. Product test reports.
- C. Sample warranty.

1.4 CLOSEOUT SUBMITTALS

- A. Maintenance data.

1.5 WARRANTY

- A. Special Warranty: Manufacturer agrees to repair or replace products that fail in materials or workmanship within specified warranty period.

PART 2 - PRODUCTS

2.1 FIBER-CEMENT SOFFIT

- A. General: ASTM C1186, Type A, Grade II, fiber-cement board, noncombustible when tested in accordance with ASTM E136; with a flame-spread index of 25 or less when tested in accordance with ASTM E84.
- B. Nominal Thickness: Not less than **5/16 inch (8 mm)**.

PART 3 - EXECUTION

3.1 INSTALLATION

- A. General: Comply with manufacturer's written installation instructions applicable to products and applications indicated unless more stringent requirements apply.
 - 1. Install fasteners no more than 24 inches (600 mm) o.c.
- B. Install joint sealants to produce a weathertight installation.

3.2 ADJUSTING AND CLEANING

- A. Remove damaged, improperly installed, or otherwise defective materials and replace with new materials complying with specified requirements.
- B. Clean finished surfaces according to manufacturer's written instructions and maintain in a clean condition during construction.

END OF SECTION 074646

SECTION 075552.16 - STYRENE-BUTADIENE-STYRENE (SBS) MODIFIED BITUMINOUS
PROTECTED MEMBRANE ROOFING

PART 1 - GENERAL

1.1 SUMMARY

A. Section Includes:

1. Styrene-butadiene-styrene (SBS)-modified bituminous protected membrane roof system.
2. Base sheet materials.
3. Interply sheets.
4. Styrene-butadiene-styrene (SBS)-modified bituminous cap sheet.
5. Base flashing sheet materials.
6. Asphalt materials.
7. Accessory roofing materials.
8. Roof insulation.
9. Insulation accessories.
10. Coating materials.

1.2 PREINSTALLATION MEETINGS

- A. Preinstallation Roofing Conference: Conduct conference at Project site.

1.3 ACTION SUBMITTALS

- A. Product Data: For each type of product, within 10 calendar days after the Contractor has received the Owner's Notice to Proceed the Roofing:

1. For insulation, include copy of FM Approvals' RoofNav listing.
2. When materials are specified or a particular make or trade name is specified, it shall be indicative of a standard required. Bidder proposing substitutes shall submit the following:
 - a. Written application with explanation of why it should be considered.
 - b. Accredited testing laboratory certificate comparing substitute's physical/performance attributes to those specified.
 - c. Smallest standard packaged of adhesive, coating, mastic, sealant, ply sheet, fastener(s) and flashing materials.
 - d. Three job references available for inspection where substitutes were used under similar conditions.
3. Only substitutions equal or better approved in writing by Owner prior to scheduled installation will be considered.
4. Manufacturer's recommended installation procedures which, when approved by the Engineer, will become the basis for accepting or rejecting actual installation procedures used on the work.

- B. Shop Drawings: Include plans, sections, details, and attachments to other work, including the following:
 - 1. Layout and thickness of insulation.
 - 2. Base flashings and membrane terminations.
 - 3. Flashing details at penetrations.
 - 4. Tie-in with adjoining air barrier.
- C. Wind Uplift Resistance Submittal: For roofing system, indicating compliance with wind uplift performance requirements.

1.4 INFORMATIONAL SUBMITTALS

- A. Manufacturer Certificates:
 - 1. Performance Requirement Certificate: Signed by roof membrane manufacturer, certifying that roofing system complies with requirements specified in "Performance Requirements" Article.
 - a. Submit evidence of compliance with performance requirements.
 - 2. Special Warranty Certificate: Signed by roof membrane manufacturer, certifying that all materials supplied under this Section are acceptable for special warranty.
- B. Product Test Reports: For roof membrane and insulation, for tests performed by a qualified testing agency, indicating compliance with specified requirements.
- C. Evaluation reports.
- D. Field Test Reports:
 - 1. Concrete internal relative humidity test reports.
- E. Field quality-control reports.
- F. Sample warranties.

1.5 CLOSEOUT SUBMITTALS

- A. Maintenance data.
- B. Certified statement from existing roof membrane manufacturer, stating that existing roof warranty has not been affected by Work performed under this Section.

1.6 QUALITY ASSURANCE

- A. Qualifications:

1. Manufacturers: A qualified manufacturer that is UL listed listed in FM Approvals' RoofNav for roofing system identical to that used for this Project.
 - a. Shall provide local Technical Sales Representative to make start-up inspection and in-progress site inspections at regular intervals.
 - b. Shall provide final inspection of completed roofing system and issuance of the warranty.
2. Contractor:
 - a. Installer Qualifications: A qualified firm that is approved, authorized, or licensed by roofing system manufacturer to install manufacturer's product.
 - b. Contractor shall retain a workmanship warranty for the specified system within the manufacturer's warranty.
 - c. Strict adherence to the manufacturer's most current published specifications are to be followed. Deviations must be approved in writing by the architect and manufacturer prior to installation.
3. Designation of Responsible Personnel.
4. Use of a subcontractor. Name and Qualifications must be approved in advance.
5. Comply with applicable codes, including but not limited to IBC-2018, PRBC-2018, Ordinances, rules and regulations of all government authorities having jurisdiction on the work, and with the required standards as applicable to the work must be complied with.
6. All materials used must show in their original individual packaging markings of an approved agency having a service for the inspection of (COLD)materials and finished products during manufacture.
7. Walkover Inspection.
 - a. Attendance: Representative of Owner/Architect, General Contractor, Roofing Contractor and Manufacturer's Technical Representative.
8. Final Inspection.
 - a. Will be scheduled by roofing contractor upon job completion.
 - b. Attendance: Representative of Owner/Architect, General Contractor, Roofing Contractor and Membrane Manufacturer's Technical Representative.
 - c. Minimum agenda:
 - 1) Walkover inspection.
 - 2) Identification of problems which may impede issuance of warranty.
 - 3) Creation of punch list.

1.7 WARRANTY

- A. Special Warranty: Manufacturer agrees to repair or replace components of roofing system that fail in materials or workmanship within specified warranty period.
 1. Warranty Period: 12 years from date of Substantial Completion.

PART 2 - PRODUCTS

2.1 PERFORMANCE REQUIREMENTS

- A. Accelerated Weathering: Roof membrane to withstand 2000 hours of exposure when tested according to ASTM G152, ASTM G154, or ASTM G155.

- B. Impact Resistance: Roof membrane to resist impact damage when tested according to ASTM D3746/D3746M, ASTM D4272/D4272M, or the "Resistance to Foot Traffic Test" in FM Approvals 4470.
- C. Wind Uplift Resistance: Design roofing system to resist the following wind uplift pressures when tested according to FM Approvals 4474, UL 580, or UL 1897:
- D. FM Approvals' RoofNav Listing: Roof membrane, base flashings, and component materials comply with requirements in FM Approvals 4450 or FM Approvals 4470 as part of a roofing system, and are listed in FM Approvals' RoofNav for Class 1 or noncombustible construction, as applicable. Identify materials with FM Approvals Certification markings.
 - 1. Fire/Windstorm Classification: Class 1A-120.
- E. Exterior Fire-Test Exposure: ASTM E108 or UL 790, Class A; for application and roof slopes indicated; testing by a qualified testing agency.
 - 1. Identify products with appropriate markings of applicable testing agency.
- F. Fire-Resistance Ratings: Comply with fire-resistance-rated assembly designs indicated.
 - 1. Identify products with appropriate markings of applicable testing agency.

2.2 MANUFACTURERS

- A. Styrene-Butadiene-Styrene (SBS)-Modified Bituminous Protected Membrane Roof System: See the following articles for individual roof materials required.

2.3 BASE SHEET MATERIALS

- A. SBS-Modified Bitumen Type I, Glass-Fiber-Mat Base Sheet: ASTM D6163/D6163M, Type I, Grade S, SBS-modified asphalt sheet, reinforced with glass fibers; smooth surfaced; suitable for cold adhesive or hot asphalt application method.
- B. Asphalt-Coated, Glass-Fiber-Mat, Venting Base Sheet: ASTM D4897/D4897M, Type II, venting, nonperforated, asphalt-impregnated and -coated, glass-fiber base sheet with mineral granule surfacing on bottom surface.

2.4 STYRENE-BUTADIENE-STYRENE (SBS)-MODIFIED BITUMINOUS CAP SHEET

- A. SBS-Modified Bitumen Type II, Polyester-Mat, Granule-Surfaced Cap Sheet: ASTM D6164/D6164M, Type II, Grade G, SBS-modified asphalt sheet, reinforced with polyester fabric; suitable for cold adhesive or hot asphalt application method.
 - 1. Granule Color: Sand or to match existing.

2.5 BASE FLASHING SHEET MATERIALS

- A. SBS-Modified Bitumen, Metal-Surfaced Flashing Sheet: ASTM D6298, metal-foil-surfaced SBS-modified asphalt sheet, reinforced with glass fibers, suitable for application method specified, and as follows:
 - 1. Metal Surfacing: Aluminum.

2.6 ASPHALT MATERIALS

- A. Asphalt Primer: ASTM D41/D41M.
- B. Elastomeric Adhesive: ASTM D3019.
- C. Elastomeric Mastic: ASTM D4586.
- D. Aluminum Coating: ASTM D2824.

2.7 ACCESSORY ROOFING MATERIALS

- A. General: Accessory materials recommended by roofing manufacturer for intended use and compatible with other roofing components.
 - 1. Adhesive and Sealants: Comply with VOC limits of authorities having jurisdiction.
- B. Prefabricated Pipe Flashings: As recommended by roof membrane manufacturer.
- C. Metal Termination Bars: Manufacturer's standard, predrilled stainless steel or aluminum bars, approximately 1 by 1/8 inch (25 by 3 mm) thick; with anchors.
- D. Cold-Applied Trichloroethylene Asphalt Adhesive: ASTM D3019, Type III, and ASTM D3409, roof membrane manufacturer's standard asphalt-based, one- or two-part, asbestos-free, cold-applied adhesive, specially formulated for compatibility and use with roofing membrane and base flashings.
- E. Cold-Applied Polymer-Modified Asphalt Adhesive: Roof membrane manufacturer's standard solvent-and asbestos-free, cold-applied adhesive, specially formulated for compatibility and use with roofing components.
- F. Asphalt Roofing Cement: ASTM D4586/D4586M, asbestos free, of consistency required by roofing system manufacturer for application.
- G. Mastic Sealant: Polyisobutylene, plain or modified bitumen; nonhardening, nonmigrating, nonskinning, and nondrying.
- H. Insulation Cant Strips: ASTM C728, perlite insulation board.
- I. Metal Flashing Sheet: Aluminum Flashing GA. 0.032.
- J. Miscellaneous Accessories: Provide accessories recommended by roofing system manufacturer.

2.8 ROOF INSULATION

A. Base/Single Layer:

1. Insulation Fastening: Single component polyurethane adhesive dispensed from a portable pre-pressurized container, when cold-adhered.
2. Thickness of Insulation: As indicated in drawings.
3. Thermal Resistance: R-value complying with ICC 2018 Energy Conservation Code.
4. Slope: 2% - Minimum Slope $\frac{1}{4}$ " per 1'-0", when cold-adhered.

2.9 INSULATION ACCESSORIES

- A. All accessories acceptable to the roofing system manufacturer.

2.10 COATING MATERIALS

A. Roof Coating:

1. ASTM D1227, Type IV, fibered, asbestos-free.
2. ASTM D2824/D2824M, Type III, fibered, asbestos-free, aluminum-pigmented asphaltic coating.
3. Flood coat and gravel: ASTM D1863 pea gravel, nominal $\frac{3}{8}$ " diameter.

2.11 RELATED MATERIALS

- A. Sealant: One part urethane.
- B. Cants: Perlite, ASTM C728, 4" face.
- C. Corrosion Resistant Fasteners: CR-10 Standard.
- D. Traffic Surfacing: Acceptable to the roofing system manufacturer.
- E. Lead Boots and Flashing: ASTM B-29, 4lb. per square foot.
- F. Roof Penetrations Protection: Acceptable to the roofing system manufacturer.
- G. Roof Insulation Foam Adhesive: Single component polyurethane adhesive dispensed from a portable pre-pressurized container.

PART 3 - EXECUTION

3.1 EXAMINATION AND PROTECTION

A. Inspection.

1. Verify installation conditions as satisfactory to receive work.

2. Do not install new roofing until all unsatisfactory conditions are corrected. Beginning work constitutes acceptance of conditions.
3. Check projections, curbs and deck for inadequate anchorage, foreign material, moisture, or unevenness that would prevent quality of execution of the new roofing system.

B. General Workmanship.

1. Substrate: Free of foreign particles prior to laying roof membrane.
2. Phased application: Not permitted, all plies shall be completed each day.
3. Confine equipment, storage of materials, debris and the operations and movement of workers within the limits agreed upon for the project.
4. Where wheeled or other traffic over partially completed roofing is unavoidable, provide adequate exterior protection to the roof.
5. Wrapper and package materials: Not to be included in roof system.
6. All metal and masonry shall be asphalt primed before fully adhering flashing sheets.
7. Mechanical fasteners: Seated firmly with fastener heads flush or below surface.
8. Base flashing height is not less than eight (8) inches above finished surface.
9. Do not install insulation that warped or damaged.

C. Protection.

1. Contractor shall be responsible for protection of property during course of work. Lawn, shrubbery, paved areas, and building shall be protected from damage at no extra cost.
2. Roofing and flashing shall be installed and sealed in a watertight manner on same day of installation or upon the arrival of inclement weather.
3. At the end of each workday, partial installation shall be sealed with water stops along edges to prevent water entry.
4. At the start of each workday, drains within daily work area shall be plugged. Plugs are to be removed at end of each workday or before arrival of inclement weather.
5. Preparation work shall be limited to those areas that can be covered with installed roofing material on same day or before arrival of inclement weather.
6. Arrange work sequence to avoid use of newly constructed roofing for storage, walking surface and equipment movement. Move equipment and ground storage areas as work progresses.

D. Surface Preparation (As applicable)

1. Remove all existing roof membrane, insulation, and flashings down to the deck and curbs.

2. Verify structural integrity of the deck. Notify the Architect of any deck or curb deficiency.
3. Remove deteriorated or damaged wood blocking and install new treated wood blocking to match existing.

3.2 PREPARATION

- A. Prime surface of concrete deck with asphalt primer at a rate of 1 gallon per 100 to 200 square feet and allow primer to dry.

3.3 INSTALLATION OF ROOFING, GENERAL

- A. Install roofing system according to roofing system manufacturer's written instructions, applicable recommendations in ARMA/NRCA's "Quality Control Guidelines for the Application of Polymer Modified Bitumen Roofing," FM Approvals' RoofNav listed roof assembly requirements, and FM Global Property Loss Prevention Data Sheet 1-29.
- B. Complete terminations and base flashings, and provide temporary seals to prevent water from entering completed sections of roofing system at the end of the workday or when rain is forecast.
 1. Remove and discard temporary seals before beginning work on adjoining roofing.
- C. Install roof membrane and accessory materials to tie in to existing roofing to maintain weathertightness of transition and to not void warranty for existing roofing system.
- D. Coordinate installation and transition of roofing system component serving as an air barrier, with air barrier acceptable to the roofing system manufacturer.
- E. Start installation of roofing in presence of manufacturer's technical personnel and Owner's testing and inspection agency.
- F. Where roof slope exceeds 3 inches per foot, install roofing sheets parallel with slope when mechanically fastened. When cold adhered, contact roofing system manufacturer.
- G. When cold adhered, roof system plies shall be laid perpendicular to the slope for slope ranges from 0-1 ½" per foot, and parallel to the slope for slopes greater than 1 ½ inches and back nailed across the width of the end lap 4 inches on center.
- H. Coordinate installation of roofing system, so components of the roofing system not permanently exposed are not subjected to precipitation or left uncovered at the end of the workday or when rain is forecast.
 1. Provide tie-offs at end of each day's work to cover exposed roofing sheets with a course of coated felt set in roofing cement, with joints and edges sealed.
 2. Complete terminations and base flashings, and provide temporary seals to prevent water from entering completed sections of roofing system.
 3. Remove and discard temporary seals before beginning work on adjoining roofing.

- I. Substrate-Joint Penetrations: Prevent roofing asphalt and adhesives from penetrating substrate joints, entering building, or damaging roofing system components or adjacent building construction.

3.4 INSTALLATION OF BASE-SHEET

- A. Before installing, unroll base sheet, cut into workable lengths, and allow to lie flat for a time period recommended by manufacturer for the ambient temperature.
- B. Installation of SBS-Modified Bitumen Polyester-Mat (top membrane), and SBS-Modified Fiberglass-Mat (base membrane) Base Sheet, Mechanically Attached (Metal Deck Roof):
 1. Substrate must be suitable to receive and hold roof system materials.
 2. Install base sheet according to roofing manufacturer's written instructions, starting at low point of roofing system.
 3. Chalk line where necessary to assure proper alignment and head lap widths of membrane plies.
 4. Install the fiberglass base sheet by mechanical attachment using appropriate fastener for the deck assembly. Fasteners shall be installed in accordance to the membrane manufacturer's base sheet fastener pattern.
 5. Use half sheet widths as starter strip.
 6. Extend roofing sheets over and terminate above cants.
 7. Install base sheet in a shingle fashion.
 8. Base sheet shall be laid smooth. Install base sheet without wrinkles, tears, fish-mouths or air pockets.
 9. Laps: Accurately align roofing sheets, without stretching, and maintain uniform side and end laps.
 - a. Lap side laps as recommended by roof membrane manufacturer but not less than **2 inches**.
 - b. Lap end laps as recommended by roof membrane manufacturer but not less than **4 inches**.
 - c. Stagger end laps not less than **24 inches**.
 - d. Completely bond and seal laps, leaving no voids.
 - e. Roll laps with roller as recommended by roof membrane manufacturer.
 10. Repair tears and voids in laps and lapped seams not completely sealed.
 11. Apply pressure to the body of the base sheet according to manufacturer's instructions, to remove air pockets and to result in complete adhesion of base sheet to substrate.
- C. Installation of SBS-Modified Fiberglass-Mat (base membrane) Base Sheet, Cold Adhered (Concrete Roof):
 1. Substrate must be suitable to receive and hold roof system materials.
 2. Install base sheet according to roofing manufacturer's written instructions, starting at low point of roofing system.
 3. Extend roofing sheets over and terminate above cants.
 4. Install base sheet in a shingle fashion.
 5. Adhere to substrate in a uniform coating of cold-applied adhesive.
 6. Base sheet shall be laid smooth. Install base sheet without wrinkles, tears, fish-mouths or air pockets.

7. Laps: Accurately align roofing sheets, without stretching, and maintain uniform side and end laps.
 - a. Lap side laps as recommended by roof membrane manufacturer but not less than **4 inches**.
 - b. Lap end laps as recommended by roof membrane manufacturer but not less than **4 inches**.
 - c. Stagger end laps not less than recommended by roof membrane manufacturer.
 - d. Completely bond and seal laps, leaving no voids.
 - e. Roll laps with a roller, as recommended by roof membrane manufacturer.
 8. Repair tears and voids in laps and lapped seams not completely sealed.
 9. Apply pressure to the body of the base sheet according to manufacturer's instructions, to remove air pockets and to result in complete adhesion of base sheet to substrate.
- D. Installation of SBS-Modified Bitumen Polyester-Mat (top membrane) Base Sheet, Cold Adhered (Concrete Roof):
1. Substrate must be suitable to receive and hold roof system materials.
 2. Install base sheet according to roofing manufacturer's written instructions, starting at low point of roofing system.
 3. Extend roofing sheets over and terminate above cants.
 4. Install base sheet in a shingle fashion.
 5. Adhere to substrate in a uniform coating of cold-applied adhesive.
 6. Base sheet shall be laid smooth. Install base sheet without wrinkles, tears, fish-mouths or air pockets.
 7. Laps: Accurately align roofing sheets, without stretching, and maintain uniform side and end laps.
 - a. Lap side laps as recommended by roof membrane manufacturer but not less than **4 inches**.
 - b. Lap end laps as recommended by roof membrane manufacturer but not less than **6 inches**.
 - c. Stagger end laps not less than recommended by roof membrane manufacturer.
 - d. Completely bond and seal laps, leaving no voids.
 - e. Roll laps with a **50-pound** roller.
 8. Repair tears and voids in laps and lapped seams not completely sealed.
 9. Apply pressure to the body of the base sheet according to manufacturer's instructions, to remove air pockets and to result in complete adhesion of base sheet to substrate.
- E. When cold adhered:
1. SBS-Modified Fiberglass-Mat (base membrane) Base Sheet and SBS-Modified Bitumen Polyester-Mat (top membrane) Base Sheet must be uniformly embedded, into the adhesive.
 2. The SBS-Modified Fiberglass-Mat (base membrane) Base Sheet is then scrolled or flapped (half roll method) into the adhesive.
 3. After adhering roll, it is recommended to apply uniform pressure to the entire roll area using a weighed roller or lawn roller water filled with an approximate weight of 80 lbs.
 4. After SBS-Modified Fiberglass-Mat (base membrane) Base Sheet is already installed and set avoiding adhesive solvent fumes, proceed with the installation of the top membrane SBS-Modified Bitumen Polyester-Mat (top membrane) Base Sheet applying a uniform coat of modified cold adhesive.

5. Precaution must be taken in order that the seam of the base ply, already adhered will lay in the middle of the width of the top layer to be applied. End laps and selvage edges of sheets being lapped must be coated with adhesive so that visible bead of adhesive (1/4" – 1/2") appears at laps as over-lapping sheets are installed.
6. Retouch seams in the top membrane applied with mineral granules or aluminum coating (asphalt based) to protect exposed asphalt during the seaming process.

F. Installation of Vented Base Sheet:

1. Spot or strip mop to substrate with hot roofing asphalt vented base sheet with vented side down.
 - a. Fasten vented base sheet according to requirements in FM Approvals' RoofNav for specified Windstorm Resistance Classification.
 - b. Fasten vented base sheet to resist uplift pressure at corners, perimeter, and field of roof.

3.5 INSTALLATION OF SBS-MODIFIED BITUMINOUS CAP SHEET (As applicable; when indicated in drawings)

- A. Before installing, unroll cap sheet, cut into workable lengths, and allow to lie flat for a time period recommended by manufacturer for the ambient temperature at which cap sheet will be installed.
- B. Install modified bituminous roofing cap sheet according to roofing manufacturer's written instructions, starting at low point of roofing system.
 1. Extend cap sheet over and terminate above cants.
 2. Install cap sheet in a shingle fashion.
 3. Install cap sheet as follows:
 - a. Adhere to substrate in a uniform coating of cold-applied adhesive.
 4. Install cap sheet without wrinkles, tears, or air pockets.
 5. Install cap sheet, so side and end laps shed water.
- C. Laps: Accurately align roofing sheets, without stretching, and maintain uniform side and end laps.
 1. Lap side laps as recommended by roof membrane manufacturer and/or as indicated in drawings.
 2. Lap end laps as recommended by roof membrane manufacturer and/or as indicated in drawings.
 3. Stagger end laps as recommended by roof membrane manufacturer and/or as indicated in drawings.
 4. Completely bond and seal laps, leaving no voids.
 5. Roll laps with a roller as recommended by roof membrane manufacturer.
 6. Repair tears and voids in laps and lapped seams not completely sealed.
- D. Apply pressure to the body of the cap sheet according to manufacturer's instructions, to remove air pockets and to result in complete adhesion of base sheet to substrate.

3.6 INSTALLATION OF FLASHING AND STRIPPING

- A. Install base flashing over cant strips and other sloping and vertical surfaces, at roof edges, and at penetrations through roof; secure to substrates according to roofing system manufacturer's written instructions and as follows:
 - 1. Prime substrates with asphalt primer if required by roofing system manufacturer.
 - 2. Flashing Sheet Application, Cold: Adhere flashing sheet to substrate in cold-applied adhesive or asphalt roofing cement at rate required by roofing system manufacturer.
 - 3. Set perlite cant in elastomeric mastic or mechanically attach.
 - 4. Install new roofing two inches minimum beyond top edge of cant.
- B. Extend base flashing up walls or parapets a minimum of **8 inches** above roofing membrane and **6 inches** onto field of roofing membrane.
- C. Mechanically fasten top of base flashing securely at terminations and perimeter of roofing.
- D. Adhere flashing membrane completely to roofing membrane. Lap sheeting ends six (6) inches. Ensure complete bond without wrinkles or voids.
- E. See detail drawings for individual flashing requirements.

3.7 INSTALLATION OF COATINGS (As applicable)

- A. Apply coating to base flashings according to manufacturer's written instructions, by spray, roller, or other suitable application method.
- B. Flood coat and gravel.
 - 1. Apply cold adhesive at a rate of 2.5 gallon per 100 square feet and embed 400-600 lbs of ASTM D1863 pea gravel, nominal 3/8" diameter.
- C. Emulsion and aluminum coating.
 - 1. Apply emulsion coating, ASTM D1227, Type IV fibrated without asbestos with a roofer's brush or airless sprayer at a rate of 3-4 gallons per square.
 - 2. After emulsion has dried, apply aluminum coating at 1-2 gallons per square.
- D. Emulsion and granules.
 - 1. Apply emulsion coating, ASTM D1227, Type IV fibrated without asbestos with a roofer's brush or airless sprayer at a rate of 3-4 gallons per square.
 - 2. While emulsion is still wet broadcast ceramic granules at rate of 60lbs. per square.
- E. Aluminum coating.
 - 1. Apply aluminum, ASTM D2824, coating with brush, roller or airless sprayer at a rate of 1-2 gallons per square.

3.8 Daily Waterstop Tie-In

- A. End of day.
 - 1. Remove debris from top ply of felt along termination, width eighteen (18) inches.

2. Adhere twelve (12) and eighteen (18) inch wide ply sheets from exposed deck to applied roofing with a continuous 1/16" inch thick application of water cut-off mastic. Extend eighteen (18) inch wide felt three (3) inches on both sides of the twelve (12) inch felt.
- B. Beginning of next day's work.
1. Remove temporary connection by cutting felts evenly along edge of existing roof system.

3.9 INSTALLATION OF INSULATION (Mechanically Fastened)

- A. Do not use damaged or warped boards.
- B. The base layer or single layer of insulation shall be mechanically fastened to the deck using corrosion resistant fasteners and plates. The length of which shall penetrate the deck 3/4".
- C. The base layer or single layer of insulation shall be applied using roof insulation foam adhesive, a single component polyurethane adhesive dispensed from a portable pre-pressurized container. When applying insulation directly to the deck, prepare the deck surface as specified here in.
- D. Loosely lay insulation over roof membrane, with long joints of insulation in continuous straight lines and with end joints staggered by one half width of the adjacent insulation boards.
1. Make joints between adjacent insulation boards not more than 1/4 inch (6 mm) in width.
 2. Fill gaps exceeding 1/4 inch (6 mm) with insulation.
 3. Cut and fit insulation within 1/4 inch (6 mm) of nailers, projections, and penetrations.
 4. Maximum elevation variation between boards at joint: 1/8 inch (12 mm).
- E. Firmly butt each insulation board to surrounding boards. Do not jam or deform boards.
- F. Install tapered insulation and its related fill using 25-30 lbs. of hot asphalt. Place tapered insulation in accordance to approved installation drawing.
- G. Install no more insulation than can be properly covered with completed roof membrane.

3.10 INSTALLATION OF INSULATION (Cold Adhered)

- A. Do not use damaged or warped boards.
- B. The base layer or single layer of rigid insulation poly-iso boards according to manufacturer's recommendations and specifications. Over concrete deck using roof insulation foam adhesive apply rows spaced 12" o.c. that spread to several inches wide before rising 3/4" to 1". The insulation board is then walked in to assure complete adhesion. The application rate must be increased for tougher surfaces and coverage rate will vary depending on roughness. (See specific instructions from manufacturer).
- C. Lay insulation in a parallel course, staggering joints by one half width of the adjacent insulation boards.
- D. Firmly butt each insulation board to surrounding boards. Do not jam or deform boards.
- E. Maximum insulation gap: 1/4" / Fill insulation board joint gaps larger than 1/4" with roof insulation.

- F. Maximum elevation variation between boards at joint: 1/8".
- G. Install tapered insulation and its related fill using 25-30 lbs. of hot asphalt. Place tapered insulation in accordance to approved installation drawing.
- H. Install no more insulation than can be properly covered with completed roof membrane.

3.11 FIELD QUALITY CONTROL

- A. Test Cuts: Test specimens will be removed to evaluate problems observed during quality-assurance inspections of roofing membrane as follows:
 - 1. Determine approximate quantities of components within roofing membrane according to ASTM D3617/D3617M.
 - 2. Examine test specimens for interply voids according to ASTM D3617/D3617M and to comply with criteria established in Appendix 3 in ARMA/NRCA's "Quality Control Guidelines for the Application of Polymer Modified Bitumen Roofing."
 - 3. Repair areas where test cuts were made according to roofing system manufacturer's written instructions.
- B. Final Roof Inspection: Arrange for roofing system manufacturer's technical personnel to inspect roofing installation on completion, in presence of Architect, and to prepare inspection report.
- C. Repair or remove and replace components of roofing system where inspections indicate that they do not comply with specified requirements.
- D. Roofing system will be considered defective if it does not pass tests and inspections.
- E. Additional testing and inspecting, at Contractor's expense, will be performed to determine if replaced or additional work complies with specified requirements.

3.12 PROTECTING AND CLEANING

- A. Protect roofing system from damage and wear during remainder of construction period.
 - 1. When remaining construction does not affect or endanger roofing, inspect roofing system for deterioration and damage, describing its nature and extent in a written report, with copies to Architect and Owner.
- B. Correct deficiencies in or remove roofing system that does not comply with requirements, repair substrates, and repair or reinstall roofing system to a condition free of damage and deterioration at time of Substantial Completion and according to warranty requirements.

END OF SECTION 075552.16

SECTION 081113 - HOLLOW METAL DOORS AND FRAMES

PART 1 - GENERAL

1.1 SUMMARY

- A. Section Includes:
 - 1. Interior custom hollow-metal doors and frames.
 - 2. Exterior custom hollow-metal doors and frames.

1.2 ACTION SUBMITTALS

- A. Product Data: For each type of product.
- B. Shop Drawings: Include the following:
 - 1. Elevations of each door type.
 - 2. Details of doors, including vertical- and horizontal-edge details and metal thicknesses.
 - 3. Frame details for each frame type, including dimensioned profiles and metal thicknesses.
- C. Product Schedule: For hollow-metal doors and frames, prepared by or under the supervision of supplier, using same reference numbers for details and openings as those on Drawings. Coordinate with final door hardware schedule.

1.3 INFORMATIONAL SUBMITTALS

- A. Product test reports.
- B. Field quality-control reports.

1.4 CLOSEOUT SUBMITTALS

- A. Record Documents: For fire-rated doors, list of door numbers and applicable room name and number to which door accesses.

PART 2 - PRODUCTS

2.1 PERFORMANCE REQUIREMENTS

- A. Fire-Rated Door Assemblies: Assemblies complying with NFPA 80 that are listed and labeled by a qualified testing agency acceptable to authorities having jurisdiction for fire-protection ratings indicated on Drawings, based on testing at positive pressure in accordance with NFPA 252 or UL 10C.

2.2 EXTERIOR CUSTOM HOLLOW-METAL DOORS AND FRAMES

A. Commercial Laminated Doors and Frames: NAAMM-HMMA 867; ANSI/SDI A250.4, Physical Performance Level A. At locations indicated in the Door and Frame Schedule on Drawings.

1. Doors:

- a. Type: As indicated in the Door and Frame Schedule on Drawings.
- b. Thickness: 1-3/4 inches (44.5 mm).
- c. Face: Metallic-coated steel sheet, minimum thickness of 0.064 inch (1.6 mm), with minimum G60 or A60 (ZF180) coating.
- d. Edge Construction: Interlocking with no visible seam.
- e. Top Edge Closures: Close top edges of doors with flush closures of same material as face sheets. Seal joints against water penetration.
- f. Bottom Edges: Close bottom edges of doors where required for attachment of weather stripping with end closures or channels of same material as face sheets. Provide weep-hole openings in bottoms of exterior doors to permit moisture to escape.
- g. Core: Polystyrene.

2. Frames:

- a. Materials: Pressed-metal, minimum thickness of 0.064 inch (1.6 mm).

2.3 FRAME ANCHORS

A. Jamb Anchors:

1. Type: Anchors of minimum size and type required by applicable door and frame standard, and suitable for performance level indicated.
2. Quantity: Minimum of three anchors per jamb, with one additional anchor for frames with no floor anchor. Provide one additional anchor for each 24 inches (610 mm) of frame height above 8 feet (2.4 m).

B. Floor Anchors: Provide floor anchors for each jamb and mullion that extends to floor.

C. Floor Anchors for Concrete Slabs with Underlayment: Adjustable-type anchors with extension clips, allowing not less than 2-inch (51-mm) height adjustment. Terminate bottom of frames at top of underlayment.

D. Material: ASTM A879/A879M, Commercial Steel (CS), 04Z (12G) coating designation; mill phosphatized.

1. For anchors built into exterior walls, steel sheet complying with ASTM A1008/A1008M or ASTM A1011/A1011M; hot-dip galvanized in accordance with ASTM A153/A153M, Class B.

2.4 MATERIALS

- A. Cold-Rolled Steel Sheet: ASTM A1008/A1008M, Commercial Steel (CS), Type B; suitable for exposed applications.
- B. Hot-Rolled Steel Sheet: ASTM A1011/A1011M, Commercial Steel (CS), Type B; free of scale, pitting, or surface defects; pickled and oiled.
- C. Metallic-Coated Steel Sheet: ASTM A653/A653M, Commercial Steel (CS), Type B.
- D. Inserts, Bolts, and Fasteners: Hot-dip galvanized in accordance with ASTM A153/A153M.
- E. Power-Actuated Fasteners in Concrete: Fastener system of type suitable for application indicated, fabricated from corrosion-resistant materials, with clips or other accessory devices for attaching hollow-metal frames of type indicated.
- F. Mineral-Fiber Insulation: ASTM C665, Type I (blankets without membrane facing); consisting of fibers manufactured from slag or rock wool; with maximum flame-spread and smoke-developed indexes of 25 and 50, respectively; passing ASTM E136 for combustion characteristics.
- G. Glazing: Comply with requirements in Section 088000 "Glazing."

2.5 FABRICATION

- A. Door Astragals: Provide overlapping astragal on one leaf of pairs of doors where required by NFPA 80 for fire-performance rating or where indicated. Extend minimum **3/4 inch (19 mm)** beyond edge of door on which astragal is mounted or as required to comply with published listing of qualified testing agency.
- B. Hollow-Metal Frames: Fabricate in one piece except where handling and shipping limitations require multiple sections. Where frames are fabricated in sections, provide alignment plates or angles at each joint, fabricated of metal of same or greater thickness as frames.
 - 1. Provide countersunk, flat- or oval-head exposed screws and bolts for exposed fasteners unless otherwise indicated.
- C. Hardware Preparation: Factory prepare hollow-metal doors and frames to receive templated mortised hardware, and electrical wiring; include cutouts, reinforcement, mortising, drilling, and tapping in accordance with ANSI/SDI A250.6, the Door Hardware Schedule on Drawings, and templates.
 - 1. Reinforce doors and frames to receive nontemplated, mortised, and surface-mounted door hardware.
 - 2. Comply with BHMA A156.115 for preparing hollow-metal doors and frames for hardware.

2.6 STEEL FINISHES

- A. Prime Finish: Clean, pretreat, and apply manufacturer's standard primer.

1. Shop Primer: Manufacturer's standard, fast-curing, lead- and chromate-free primer complying with ANSI/SDI A250.10; recommended by primer manufacturer for substrate; compatible with substrate and field-applied coatings despite prolonged exposure.

PART 3 - EXECUTION

3.1 PREPARATION

- A. Drill and tap doors and frames to receive nontemplated, mortised, and surface-mounted door hardware.

3.2 INSTALLATION

A. Hollow-Metal Frames:

1. Set frames accurately in position; plumbed, aligned, and braced securely until permanent anchors are set. After wall construction is complete, remove temporary braces without damage to completed Work.
 - a. Install frames with removable stops located on secure side of opening.
2. Fire-Rated Openings: Install frames in accordance with NFPA 80.
3. Floor Anchors: Secure with postinstalled expansion anchors.
4. Masonry Walls: Coordinate installation of frames to allow for solidly filling space between frames and masonry with grout or mortar.
5. In-Place Concrete or Masonry Construction: Secure frames in place with postinstalled expansion anchors. Countersink anchors, and fill and make smooth, flush, and invisible on exposed faces.
6. Installation Tolerances: Adjust hollow-metal frames to the following tolerances:
 - a. Squareness: Plus or minus **1/16 inch (1.6 mm)**, measured at door rabbet on a line 90 degrees from jamb perpendicular to frame head.
 - b. Alignment: Plus or minus **1/16 inch (1.6 mm)**, measured at jambs on a horizontal line parallel to plane of wall.
 - c. Twist: Plus or minus **1/16 inch (1.6 mm)**, measured at opposite face corners of jambs on parallel lines, and perpendicular to plane of wall.
 - d. Plumbness: Plus or minus **1/16 inch (1.6 mm)**, measured at jambs at floor.

- B. Hollow-Metal Doors: Fit and adjust hollow-metal doors accurately in frames, within clearances specified below.

1. Fire-Rated Doors: Install doors with clearances in accordance with NFPA 80.

3.3 FIELD QUALITY CONTROL

- A. Inspection Agency: Owner will engage a qualified inspector to perform inspections and to furnish reports to Architect.

- B. Inspections:

1. Fire-Rated Door Inspections: Inspect each fire-rated door in accordance with NFPA 80, Section 5.2.
 - C. Repair or remove and replace installations where inspections indicate that they do not comply with specified requirements.
 - D. Reinspect repaired or replaced installations to determine if replaced or repaired door assembly installations comply with specified requirements.

3.4 REPAIR

- A. Metallic-Coated Surface Touchup: Clean abraded areas and repair with galvanizing repair paint in accordance with manufacturer's written instructions.

END OF SECTION 081113

SECTION 081416 - FLUSH WOOD DOORS

PART 1 - GENERAL

1.1 SUMMARY

A. Section Includes:

1. Solid-core doors with medium-density overlay faces.

B. Related Sections:

1. Division 09 Sections "Exterior Painting" and "Interior Painting" for field finishing doors.

1.2 SUBMITTALS

- A. Product Data: For each type of door indicated. Include details of core and edge construction and trim for openings. Include factory-finishing specifications.

- B. Shop Drawings: Indicate location, size, and hand of each door; elevation of each kind of door; construction details not covered in Product Data; location and extent of hardware blocking; and other pertinent data.

1. Indicate fire-protection ratings for fire-rated doors.

- C. Warranty: Sample of special warranty.

1.3 QUALITY ASSURANCE

- A. Manufacturer Qualifications: A qualified manufacturer that is certified for chain of custody by an FSC-accredited certification body.

- B. Source Limitations: Obtain flush wood doors from single manufacturer.

- C. Quality Standard: In addition to requirements specified, comply with AWI's "Architectural Woodwork Quality Standards Illustrated".

1. Provide AWI Quality Certification Labels or an AWI letter of licensing for Project indicating that doors comply with requirements of grades specified.

- D. Fire-Rated Wood Doors: Doors complying with NFPA 80 that are listed and labeled by a qualified testing agency, for fire-protection ratings indicated, based on testing at positive pressure according to NFPA 252, UBC Standard 7-2 or UL 10C.

- E. Preinstallation Conference: Conduct conference at Project site.

1.4 DELIVERY, STORAGE, AND HANDLING

- A. Comply with requirements of referenced standard and manufacturer's written instructions.
- B. Package doors individually in plastic bags or cardboard cartons.
- C. Mark each door on bottom rail with opening number used on Shop Drawings.

1.5 PROJECT CONDITIONS

- A. Environmental Limitations: Do not deliver or install doors until spaces are enclosed and weathertight, wet work in spaces is complete and dry, and HVAC system is operating and maintaining ambient temperature and humidity conditions at occupancy levels during the remainder of the construction period.

1.6 WARRANTY

- A. Special Warranty: Manufacturer's standard form in which manufacturer agrees to repair or replace doors that fail in materials or workmanship within specified warranty period.
 - 1. Warranty shall also include installation and finishing that may be required due to repair or replacement of defective doors.

PART 2 - PRODUCTS

2.1 MANUFACTURERS

- A. Manufacturers: Subject to compliance with requirements, available manufacturers offering products that may be incorporated into the Work include, but are not limited to, the following:
 - 1. Home Depot.
 - 2. National Lumber & Hardware, Inc.
 - 3. Submit local manufacturer for approval.

2.2 DOOR CONSTRUCTION, GENERAL

- A. Fire-Protection-Rated Doors: Provide core specified or mineral core as needed to provide fire-protection rating indicated.
 - 1. Edge Construction: Comply with specified requirements for exposed edges.
 - 2. Species: Solid Mahogany 1 ¾"

2.3 DOORS FOR OPAQUE FINISH

- A. Interior Solid-Core Doors:

1. Grade: Custom.
2. Faces: Medium-density overlay.
 - a. Apply medium-density overlay to standard-thickness, closed-grain, hardwood face veneers.

2.4 FABRICATION

- A. Factory fit doors to suit frame-opening sizes indicated. Comply with clearance requirements of referenced quality standard for fitting unless otherwise indicated.
 1. Comply with requirements in NFPA 80 for fire-rated doors.

2.5 FACTORY FINISHING

- A. General: Comply with referenced quality standard for factory finishing. Complete fabrication, including fitting doors for openings and machining for hardware that is not surface applied, before finishing.
 1. Finish faces, all four edges, edges of cutouts, and mortises.
- B. Field finish doors indicated to receive transparent or opaque finish.
- C. Transparent Finish:
 1. Grade: Custom.
 2. Finish: AWI conversion varnish system.
 3. Staining: As selected by Architect from manufacturer's full range.
 4. Effect: Open-grain finish.
 5. Sheen: Semigloss.
- D. Opaque Finish:
 1. Grade: Custom.
 2. Finish: AWI conversion varnish system.
 3. Color: As selected by Architect from manufacturer's full range.
 4. Sheen: Gloss.

PART 3 - EXECUTION

3.1 EXAMINATION

- A. Examine doors and installed door frames before hanging doors.
 1. Verify that frames comply with indicated requirements for type, size, location, and swing characteristics and have been installed with level heads and plumb jambs.
 2. Reject doors with defects.

- B. Proceed with installation only after unsatisfactory conditions have been corrected.

3.2 INSTALLATION

- A. Hardware: For installation, see Division 08 Section "Door Hardware."
- B. Installation Instructions: Install doors to comply with manufacturer's written instructions and the referenced quality standard, and as indicated.
 - 1. Install fire-rated doors in corresponding fire-rated frames according to NFPA 80.
- C. Job-Fitted Doors: Align and fit doors in frames with uniform clearances and bevels as indicated below; do not trim stiles and rails in excess of limits set by manufacturer or permitted for fire-rated doors. Machine doors for hardware. Seal edges of doors, edges of cutouts, and mortises after fitting and machining.
 - 1. Clearances: Provide 1/8 inch (3.2 mm) at heads, jambs, and between pairs of doors. Provide 1/8 inch (3.2 mm) from bottom of door to top of decorative floor finish or covering unless otherwise indicated. Where threshold is shown or scheduled, provide 1/4 inch (6.4 mm) from bottom of door to top of threshold unless otherwise indicated.
 - a. Comply with NFPA 80 for fire-rated doors.
 - 2. Bevel non-fire-rated doors 1/8 inch in 2 inches (3-1/2 degrees) at lock and hinge edges.
 - 3. Bevel fire-rated doors 1/8 inch in 2 inches (3-1/2 degrees) at lock edge; trim stiles and rails only to extent permitted by labeling agency.
- D. Factory-Fitted Doors: Align in frames for uniform clearance at each edge.

3.3 ADJUSTING

- A. Operation: Rehang or replace doors that do not swing or operate freely.
- B. Finished Doors: Replace doors that are damaged or that do not comply with requirements. Doors may be repaired or refinished if work complies with requirements and shows no evidence of repair or refinishing.

END OF SECTION 081416

SECTION 083323 - OVERHEAD COILING DOORS

PART 1 - GENERAL

1.1 SUMMARY

- A. Section Includes:
 - 1. Service doors.
- B. Related Requirements:

1.2 ACTION SUBMITTALS

- A. Product Data: For each type and size of overhead coiling door and accessory.
- B. Shop Drawings: For each installation and for special components not dimensioned or detailed in manufacturer's product data.
 - 1. Include points of attachment and their corresponding static and dynamic loads imposed on structure.
- C. Samples: For each exposed product and for each color and texture specified.

1.3 INFORMATIONAL SUBMITTALS

- A. Sample warranty.

1.4 CLOSEOUT SUBMITTALS

- A. Special warranty.
- B. Maintenance data.
- C. Record Documents: For fire-rated doors, list of door numbers and applicable room name and number to which door accesses.

1.5 QUALITY ASSURANCE

- A. Installer Qualifications: An entity that employs installers and supervisors who are trained and approved by manufacturer for both installation and maintenance of units required for this Project.

1.6 WARRANTY

- A. Special Warranty: Manufacturer agrees to repair or replace components of doors that fail in materials or workmanship within specified warranty period.
 - 1. Warranty Period: Insert number years from date of Substantial Completion.

PART 2 - PRODUCTS

2.1 PERFORMANCE REQUIREMENTS

- A. Accessibility Standard: Comply with applicable provisions in the USDOJ's "2010 ADA Standards for Accessible Design" and ICC A117.1.
- B. Windborne-Debris Impact Resistance: Provide impact-protective overhead coiling doors that pass ASTM E1886 missile-impact and cyclic-pressure tests according to ASTM E1996 for Wind Zone 1 ASTM E1996 for Wind Zone 2 ASTM E1996 for Wind Zone 3 ASTM E1996 for Wind Zone 4 for basic enhanced protection.
- C. Seismic Performance: Overhead coiling doors withstand the effects of earthquake motions determined according to ASCE/SEI 7, if applicable to Project location.

2.2 DOOR ASSEMBLY

- A. Service Door: Overhead coiling door formed with curtain of interlocking metal slats.
- B. Door Curtain Material: Galvanized steel.
- C. Door Curtain Slats: Curved profile slats.
- D. Bottom Bar: Two angles, each not less than 1-1/2 by 1-1/2 by 1/8 inch (38 by 38 by 3 mm) thick; fabricated from hot-dip galvanized steel stainless steel or aluminum extrusions and finished to match door.
- E. Curtain Jamb Guides: Galvanized steel with exposed finish matching curtain slats.
- F. Hood: Match curtain material and finish.
 - 1. Mounting: Face of wall.
- G. Locking Devices: Equip door with chain lock keeper.
- H. Manual Door Operator: Chain-hoist operator.
- I. Curtain Accessories: Equip door with smoke seals weatherseals astragal push/pull handles pull-down strap.
- J. Door Finish:

1. Aluminum Finish: Clear anodized.
2. Stainless Steel Finish: ASTM A480/A480M No. 4 (polished directional satin).

2.3 MATERIALS, GENERAL

- A. Electrical Components, Devices, and Accessories: Listed and labeled as defined in NFPA 70, by a qualified testing agency, and marked for intended location and application.

2.4 DOOR CURTAIN MATERIALS AND CONSTRUCTION

- A. Door Curtains: Fabricate overhead coiling-door curtain of interlocking metal slats, designed to withstand wind loading indicated, in a continuous length for width of door without splices. Unless otherwise indicated, provide slats of thickness and mechanical properties recommended by door manufacturer for performance, size, and type of door indicated, and as follows:
 1. Metal Interior Curtain-Slat Facing: Match metal of exterior curtain-slat face, with minimum steel thickness of **0.010 inch (0.25 mm)** and minimum aluminum thickness of **0.032 inch (0.80 mm)**.
- B. Curtain Jamb Guides: Manufacturer's standard angles or channels and angles of same material and finish as curtain slats unless otherwise indicated, with sufficient depth and strength to retain curtain, to allow curtain to operate smoothly, and to withstand loading. Slot bolt holes for guide adjustment. Provide removable stops on guides to prevent overtravel of curtain.

2.5 HOODS

- A. General: Form sheet metal hood to entirely enclose coiled curtain and operating mechanism at opening head. Contour to fit end brackets to which hood is attached. Roll and reinforce top and bottom edges for stiffness. Form closed ends for surface-mounted hoods and fascia for any portion of between-jamb mounting that projects beyond wall face. Equip hood with intermediate support brackets as required to prevent sagging.
 1. Include automatic drop baffle on fire-rated doors to guard against passage of smoke or flame.
 2. Exterior-Mounted Doors: Fabricate hood to act as weather protection and with a perimeter sealant-joint-bead profile for applying joint sealant.

2.6 LOCKING DEVICES

- A. Slide Bolt: Fabricate with side-locking bolts to engage through slots in tracks for locking by padlock, located on both left and right jamb sides, operable from coil side.
- B. Chain Lock Keeper: Suitable for padlock.
- C. Safety Interlock Switch: Equip power-operated doors with safety interlock switch to disengage power supply when door is locked.

2.7 CURTAIN ACCESSORIES

- A. Smoke Seals: Equip each fire-rated door with replaceable smoke-seal perimeter gaskets or brushes for smoke and draft control as required for door listing and labeling by a qualified testing agency.
- B. Weatherseals for Exterior Doors: Equip each exterior door with weather-stripping gaskets fitted to entire exterior perimeter of door for a weather-resistant installation unless otherwise indicated.
- C. Astragal for Interior Doors: Equip each door bottom bar with a replaceable, adjustable, continuous, compressible gasket of flexible vinyl, rubber, or neoprene as a cushion bumper.
- D. Push/Pull Handles: Equip each push-up-operated or emergency-operated door with lifting handles on each side of door, finished to match door.
- E. Pull-Down Strap: Provide pull-down straps for doors more than **84 inches (2130 mm)** high.

2.8 COUNTERBALANCE MECHANISM

- A. General: Counterbalance doors by means of manufacturer's standard mechanism with an adjustable-tension, steel helical torsion spring mounted around a steel shaft and contained in a spring barrel connected to top of curtain with barrel rings. Use grease-sealed bearings or self-lubricating graphite bearings for rotating members.
- B. Brackets: Manufacturer's standard mounting brackets of either cast iron or cold-rolled steel plate.

2.9 MANUAL DOOR OPERATORS

- A. General: Equip door with manual door operator by door manufacturer.
- B. Push-up Door Operation: Lift handles and pull rope for raising and lowering doors, with counterbalance mechanism designed so that required lift or pull for door operation does not exceed **25 lbf (111 N)**.
- C. Chain-Hoist Operator: Consisting of endless steel hand chain, chain-pocket wheel and guard, and gear-reduction unit with a maximum **25-lbf (111-N) 30-lbf (133-N)** force for door operation. Provide alloy-steel hand chain with chain holder secured to operator guide.
- D. Crank Operator: Consisting of crank and crank gearbox, steel crank drive shaft, and gear-reduction unit, of type indicated. Size gears to require not more than **25-lbf (111-N) 30-lbf (133-N)** force to turn crank. Fabricate gearbox to be oiltight and to completely enclose operating mechanism. Provide manufacturer's standard crank-locking device.

PART 3 - EXECUTION

3.1 INSTALLATION, GENERAL

- A. Install overhead coiling doors and operating equipment complete with necessary hardware, anchors, inserts, hangers, and equipment supports; according to manufacturer's written instructions and as specified.
- B. Fire-Rated Doors: Install according to NFPA 80.
- C. Smoke-Control Doors: Install according to NFPA 80 and NFPA 105.

3.2 FIELD QUALITY CONTROL

- A. Perform tests and inspections with the assistance of a factory-authorized service representative.
- B. Repair or remove and replace installations where inspections indicate that they do not comply with specified requirements.
- C. Reinspect repaired or replaced installations to determine if replaced or repaired door assembly installations comply with specified requirements.

3.3 DEMONSTRATION

- A. Engage a factory-authorized service representative to train Owner's maintenance personnel to adjust, operate, and maintain overhead coiling doors.

END OF SECTION 083323

SECTION 085113 - ALUMINUM WINDOWS

PART 1 - GENERAL

1.1 SUMMARY

- A. Section includes aluminum windows for exterior locations.

1.2 PREINSTALLATION MEETINGS

- A. Preinstallation Conference: Conduct conference at Project site.

1.3 ACTION SUBMITTALS

- A. Product Data: For each type of product.
- B. Shop Drawings: Include plans, elevations, sections, hardware, accessories, insect screens, operational clearances, and details of installation, including anchor, flashing, and sealant installation.
- C. Samples: For each exposed product and for each color specified.

1.4 INFORMATIONAL SUBMITTALS

- A. Product test reports.
- B. Sample warranties.

1.5 WARRANTY

- A. Manufacturer's Warranty: Manufacturer agrees to repair or replace aluminum windows that fail in materials or workmanship within specified warranty period.

PART 2 - PRODUCTS

2.1 WINDOW PERFORMANCE REQUIREMENTS

- A. Product Standard: Comply with AAMA/WDMA/CSA 101/I.S.2/A440 for definitions and minimum standards of performance, materials, components, accessories, and fabrication unless more stringent requirements are indicated.
- B. Performance Class and Grade: AAMA/WDMA/CSA 101/I.S.2/A440 as follows:

1. Minimum Performance Class: <Insert class>.
 2. Minimum Performance Grade: <Insert grade>.
- C. Windborne-Debris Impact Resistance: Passes ASTM E1886 missile-impact and cyclic-pressure tests in accordance with ASTM E1996 for Wind Zone for protection.
1. Large-Missile Test: For glazing located within <Insert dimension> of grade.
 2. Small-Missile Test: For glazing located between 30 feet (9.1 m) and <Insert dimension> above grade.

2.2 ALUMINUM WINDOWS

- A. Types: Aluminum Jalousie Windows.
- B. Frames and Sashes: Aluminum extrusions complying with AAMA/WDMA/CSA 101/I.S.2/A440.
1. Thermally Improved Construction: Fabricate frames, sashes, and muntins with an integral, concealed, low-conductance thermal barrier located between exterior materials and window members exposed on interior side in a manner that eliminates direct metal-to-metal contact.
- C. Hardware, General: Provide manufacturer's standard corrosion-resistant hardware sized to accommodate sash weight and dimensions.
1. Exposed Hardware Color and Finish: As selected by Architect from manufacturer's full range.
- D. Weather Stripping: Provide full-perimeter weather stripping for each operable sash unless otherwise indicated.
- E. Fasteners: Noncorrosive and compatible with window members, trim, hardware, anchors, and other components.
1. Exposed Fasteners: Do not use exposed fasteners to greatest extent possible. For application of hardware, use fasteners that match finish hardware being fastened.

2.3 FABRICATION

- A. Fabricate aluminum windows in sizes indicated. Include a complete system for assembling components and anchoring windows.
- B. Weather strip each operable sash to provide weathertight installation.
- C. Weep Holes: Provide weep holes and internal passages to conduct infiltrating water to exterior.
- D. Mullions: Provide mullions and cover plates, matching window units, complete with anchors for support to structure and installation of window units. Allow for erection tolerances and provide for movement of window units due to thermal expansion and building deflections. Provide mullions and cover plates capable of withstanding design wind loads of window units.

- E. Complete fabrication, assembly, finishing, hardware application, and other work in the factory to greatest extent possible. Disassemble components only as necessary for shipment and installation.

2.4 ALUMINUM FINISHES

- A. Finish designations prefixed by AA comply with the system established by the Aluminum Association for designating aluminum finishes.
- B. Baked-Enamel Finish: AA-C12C42R1x (Chemical Finish: cleaned with inhibited chemicals; Chemical Finish: acid-chromate-fluoride-phosphate conversion coating; Organic Coating: as specified below). Apply baked enamel complying with paint manufacturer's written instructions for cleaning, conversion coating, and painting.
 - 1. Organic Coating: Thermosetting, modified-acrylic or polyester enamel primer/topcoat system complying with AAMA 2603, except with a minimum dry film thickness of **1.5 mils (0.04 mm)**, medium gloss.
 - 2. Color: As selected by Architect from full range of industry colors and color densities.

PART 3 - EXECUTION

3.1 INSTALLATION

- A. Comply with manufacturer's written instructions for installing windows, hardware, accessories, and other components. For installation procedures and requirements not addressed in manufacturer's written instructions, comply with installation requirements in ASTM E2112.
- B. Install windows level, plumb, square, true to line, without distortion or impeding thermal movement, anchored securely in place to structural support, and in proper relation to wall flashing and other adjacent construction to produce weathertight construction.
- C. Install windows and components to drain condensation, water penetrating joints, and moisture migrating within windows to the exterior.
- D. Separate aluminum and other corrodible surfaces from sources of corrosion or electrolytic action at points of contact with other materials.
- E. Adjust operating sashes and hardware for a tight fit at contact points and weather stripping for smooth operation and weathertight closure.
- F. Clean exposed surfaces immediately after installing windows. Avoid damaging protective coatings and finishes. Remove excess sealants, glazing materials, dirt, and other substances.

END OF SECTION 085113

SECTION 087111 - DOOR HARDWARE (DESCRIPTIVE SPECIFICATION)

PART 1 - GENERAL

1.1 SUMMARY

A. Section Includes:

1. Hinges.
2. Bored locks.
3. Mortise locks.
4. Bored auxiliary locks.
5. Mortise auxiliary locks.
6. Exit devices and auxiliary items.
7. Lock cylinders.
8. Surface closers.
9. Closer holder release devices.
10. Wall- and floor-mounted stops.
11. Door gasketing.
12. Thresholds.

1.2 PREINSTALLATION MEETINGS

- A. Preinstallation Conference: Conduct conference at Project site.
- B. Keying Conference: Conduct conference at Project site.

1.3 ACTION SUBMITTALS

- A. Product data.
- B. Shop Drawings.
- C. Samples: For each exposed product in each finish specified.
- D. Door hardware schedule.
- E. Keying schedule.

1.4 INFORMATIONAL SUBMITTALS

- A. Sample warranty.

1.5 CLOSEOUT SUBMITTALS

- A. Maintenance data.

1.6 QUALITY ASSURANCE

- A. Installer Qualifications: Supplier of products and an employer of workers trained and approved by product manufacturers and of an Architectural Hardware Consultant who is available during the course of the Work to consult Contractor, Architect, and Owner about door hardware and keying.
 - 1. Scheduling Responsibility: Preparation of door hardware and keying schedule.

1.7 WARRANTY

- A. Special Warranty: Manufacturer agrees to repair or replace components of door hardware that fail in materials or workmanship within specified warranty period.

PART 2 - PRODUCTS

2.1 PERFORMANCE REQUIREMENTS

- A. Fire-Rated Door Assemblies: Where fire-rated doors are indicated, provide door hardware complying with NFPA 80 that is listed and labeled by a qualified testing agency, for fire-protection ratings indicated, based on testing at positive pressure in accordance with NFPA 252 or UL 10C.
- B. Means of Egress Doors: Latches do not require more than 15 lbf (67 N) to release the latch. Locks do not require use of a key, tool, or special knowledge for operation.
- C. Accessibility Requirements: For door hardware on doors in an accessible route, comply with the USDOJ's "2010 ADA Standards for Accessible Design".

2.2 HINGES

- A. Hinges: ANSI/BHMA A156.1. Provide template-produced hinges for hinges installed on hollow-metal doors and hollow-metal frames.
- B. Antifriction-Bearing Hinges:
 - 1. Mounting: Full mortise (butts).
 - 2. Bearing Material: Manufacturer's standard antifriction bearing.
 - 3. Grade 1 (heavy weight).
 - 4. Base and Pin Metal:
 - a. Exterior Hinges: Stainless steel with stainless steel pin.
 - b. Interior Hinges: Stainless steel with stainless steel pin.

- c. Hinges for Fire-Rated Assemblies: Stainless steel with stainless steel pin.
- 5. Pins: Nonremovable.
- 6. Tips: Flat button.
- 7. Corners: Square.
- 8. Features: Safety stud.

2.3 EXIT DEVICES AND AUXILIARY ITEMS

- A. Exit Devices and Auxiliary Items: ANSI/BHMA A156.3.
- B. Panic Exit Devices: Listed and labeled by a testing and inspecting agency acceptable to authorities having jurisdiction, for panic protection, based on testing in accordance with UL 305.
- C. Fire Exit Devices: Devices complying with NFPA 80 that are listed and labeled by a testing and inspecting agency acceptable to authorities having jurisdiction, for fire and panic protection, based on testing in accordance with UL 305 and NFPA 252.
- D. Surface Vertical-Rod Exit Devices: Grade 1.
 - 1. Type 2 Type 5, narrow stile.
 - 2. Actuating Bar: Push pad Narrow-stile push pad.
 - 3. Material: Bronze.
 - 4. Configuration: Top and bottom rods.
- E. Combination Exit Devices: Grade 1.
 - 1. Type 11, mortise and surface vertical rod.
 - 2. Actuating Bar: Push pad Narrow-stile push pad.
 - 3. Material: Bronze.

2.4 LOCK CYLINDERS

- A. Lock Cylinders: Tumbler type, constructed from brass or bronze, stainless steel, or nickel silver. Provide cylinder from same manufacturer of locking devices.
- B. Standard Lock Cylinders: ANSI/BHMA A156.5, Grade 1 permanent cores; face finished to match lockset.
 - 1. Core Type: Interchangeable.
 - 2. Number of Pins: Seven.
 - 3. Lock Type: Mortise type.

2.5 KEYING

- A. Keying System: Factory registered, complying with guidelines in ANSI/BHMA A156.28, appendix. Provide one extra key blank for each lock. Incorporate decisions made in keying conference.
 - 1. No Master Key System: Only change keys operate cylinders.
 - a. Provide three cylinder change keys.
 - 2. Existing System:
 - a. Master key or grand master key locks to Owner's existing system.
 - b. Re-key Owner's existing master key system into new keying system.
- B. Keys: Nickel silver Brass.

2.6 OPERATING TRIM

- A. Operating Trim: ANSI/BHMA A156.6; bronze unless otherwise indicated.

2.7 ACCESSORIES FOR PAIRS OF DOORS

- A. Flat Overlapping Astragals: ANSI/BHMA A156.22; flat primed steel metal bar, surface mounted on face of door with screws; minimum **1/8 inch (3.2 mm)** thick by **2 inches (51 mm)** wide by full height of door.

2.8 SURFACE CLOSERS

- A. Surface Closers: ANSI/BHMA A156.4; rack-and-pinion hydraulic type with adjustable sweep and latch speeds controlled by key-operated valves and forged-steel main arm. Comply with manufacturer's written instructions for size of door closers depending on size of door, exposure to weather, and anticipated frequency of use. Provide factory-sized closers, adjustable to meet field conditions and requirements for opening force.
- B. Cast-Aluminum Surface Closers: Grade 1; traditional type with mechanism enclosed in cast-aluminum alloy shell.
 - 1. Mounting: Hinge side.
 - 2. Type: Regular arm Delayed-action closing.

2.9 MECHANICAL STOPS AND HOLDERS

- A. Wall- and Floor-Mounted Stops: ANSI/BHMA A156.16; polished cast-brass, -bronze, or -aluminum base metal.
- B. Rigid-Type Floor Stop: Grade 1; with rubber bumper.

1. Installation: Surface-screw installation.

2.10 DOOR GASKETING

- A. Door Gasketing: ANSI/BHMA A156.22; with resilient or flexible seal strips that are easily replaceable and readily available from stocks maintained by manufacturer.
- B. Maximum Air Leakage: When tested in accordance with ASTM E283/E283M with tested pressure differential of **0.3 inch wg (75 Pa)**, as follows:
 1. Gasketing on Single Doors: **0.3 cfm/sq. ft. (3 cu. m per minute/sq. m)** of door opening.
 2. Gasketing on Double Doors: **0.50 cfm per ft. (0.000774 cu. m/s per m)** of door opening.
- C. Adhesive-Backed Perimeter Gasketing: Vinyl bulb gasket material applied to frame rabbet with self-adhesive.
- D. Meeting Astragals for Meeting Stiles: Vinyl bulb gasket material held in place by housing; mounted with screws.
 1. Housing Material: Bronze.
 2. Mounting: Surface mounted on face of one door.
- E. Door Sweeps: Vinyl gasket material held in place by flat housing or flange; surface mounted to face of door with screws.
 1. Housing or Flange Material: Bronze.

2.11 FINISHES

- A. Provide finishes complying with ANSI/BHMA A156.18 as indicated in door hardware schedule.

PART 3 - EXECUTION

3.1 INSTALLATION

- A. Mounting Heights: Mount door hardware units at heights to comply with the following unless otherwise indicated or required to comply with governing regulations.
 1. Standard Steel Doors and Frames: ANSI/SDI A250.8.
 2. Wood Doors: DHI's "Recommended Locations for Architectural Hardware for Wood Flush Doors."
- B. Install each door hardware item to comply with manufacturer's written instructions. Where cutting and fitting are required to install door hardware onto or into surfaces that are later to be painted or finished in another way, coordinate removal, storage, and reinstallation of surface protective trim units with finishing work. Do not install surface-mounted items until finishes have been completed on substrates involved.

1. Set units level, plumb, and true to line and location. Adjust and reinforce attachment substrates as necessary for proper installation and operation.
 2. Drill and countersink units that are not factory prepared for anchorage fasteners. Space fasteners and anchors in accordance with industry standards.
- C. Hinges: Install types and in quantities indicated in door hardware schedule, but not fewer than the number recommended by manufacturer for application indicated or one hinge for every **30 inches (760 mm)** of door height, whichever is more stringent, unless other equivalent means of support for door, such as spring hinges or pivots, are provided.
- D. Intermediate Offset Pivots: Where offset pivots are indicated, provide intermediate offset pivots in quantities indicated in door hardware schedule, but not fewer than one intermediate offset pivot per door and one additional intermediate offset pivot for every **30 inches (760 mm)** of door height greater than **90 inches (2286 mm)**.
- E. Lock Cylinders: Install construction cores to secure building and areas during construction period.
1. Replace construction cores with permanent cores as directed by Owner.
- F. Stops: Provide floor stops for doors unless wall or other type stops are indicated in door hardware schedule. Do not mount floor stops where they will impede traffic.
- G. Perimeter Gasketing: Apply to head and jamb, forming seal between door and frame.
1. Do not notch perimeter gasketing to install other surface-applied hardware.
- H. Meeting Stile Gasketing: Fasten to meeting stiles, forming seal when doors are closed.

3.2 ADJUSTING

- A. Initial Adjustment: Adjust and check each operating item of door hardware and each door to ensure proper operation or function of every unit. Replace units that cannot be adjusted to operate as intended. Adjust door control devices to compensate for final operation of heating and ventilating equipment and to comply with referenced accessibility requirements.

3.3 DOOR HARDWARE SCHEDULE

Hardware Set #1 Entrance Doors						
Qt.	Name	Description	Dims	Material/ Finish	Grade and Compliance	Comments
6	Hinges	Ball bearing hinge with five knuckles	4-1/2" x 4 1/2"	26D	ANSI/8111 ANSI/BHMA standards for ANSI A156.1 NFPA80 requirements for use on fire rated door assemblies	With bottom tip and plug with a non-rising removable steel pin with button tip and plug.

2	Vertical Rod exit device	Two Surface Mounted Vertical Rod Type - Swinging in same direction	96" Height	26D	ANSI/BHMA A156.3, Grade 1 NFPA 101 Compliant UL 305 - Standard for Panic Hardware UL-listed for FEMA P-361 (2015) Americans with Disabilities Act (ADA) Compliant ANSI/BHMA A156.41 UL-cUL Fire-Rated Up to 3 Hours NFPA 80 Compliant ICC A117.1 Compliant	5-year limited warranty Shall be certified to meet or exceed the requirements of ANSI/BHMA A156.3 Grade 1 UL-listed for FEMA P-361 (2015)
2	Door closer	Fully adjustable / One-piece high strength aluminum alloy body 1-1/4" diameter piston	1-1/4" diameter piston	26D	ANSI/BHMA A156.4, Grade 1 Americans with Disabilities Act (ADA) Compliant ICC A117.1 Compliant UL-cUL Fire-Rated Up to 3 Hours	
1	Lockset	Mortise			ANSI/BHMA Code: A156.13 ANSI/BHMA Series: Series 1000 ADA compliant	Grade 1 5 Year Limited Warranty Grade 1 5 Year Limited Warranty
4	Threshold		6" x 60" 6 X 36" 6" x 42"		Fire Rated, ADA Compliant, BHMA Certified	Heavy Duty 5 Year Limited Warranty
2	Door stop	8" Heavy Duty Plunger Door Holder	8"			Heavy Duty Mounts to the bottom of the door

Hardware Set #2 Entrance Door (Single)						
Qt.	Name	Description	Dims	Material/Finish	Grade and Compliance	Comments
3	Hinges	Ball bearing hinge with five knuckles with bottom tip and plug with a non-rising removable steel pin with button tip and plug.	4-1/2" x 41/2"	26D	ANSI/8111 ANSI/BHMA standards for ANSI A156.1 NFPA80 requirements for use on fire rated door assemblies	

1	Panic device w/Vertical Rod exit device	Two Surface Mounted Vertical Rod Type - Swinging in same direction	96" Height	26D	ANSI/BHMA A156.3, Grade 1 NFPA 101 Compliant UL 305 - Standard for Panic Hardware Americans with Disabilities Act (ADA) Compliant ANSI/BHMA A156.41 UL-cUL Fire-Rated Up to 3 Hours NFPA 80 Compliant ICC A117.1 Compliant	5-year limited warranty Shall be certified to meet or exceed the requirements of ANSI/BHMA A156.3 Grade 1
1	Door closer	Fully adjustable door closer One-piece high strength aluminum alloy body 1-1/4" diameter piston for enhanced control	1-1/4" diameter piston	26D	ANSI/BHMA A156.4, Grade 1 Americans with Disabilities Act (ADA) Compliant ICC A117.1 Compliant UL-cUL Fire-Rated Up to 3 Hours	
1	Lockset	Mortise lock		26D	ANSI/BHMA Code: A156.13 ANSI/BHMA Series: Series 1000 ADA compliant	Grade 1 5 Year Limited Warranty
4	Threshold		6"x 60" 6 X 36" 6"x 42"		Fire Rated, ADA Compliant, BHMA Certified	Heavy Duty 5 Year Limited Warranty
1	Door stop	8" Heavy Duty Plunger Door Holder				Heavy Duty Mounts to the bottom of the door

Hardware Set #3 Interior Doors						
Qt.	Name	Description	Dims	Material/Finish	Grade and Compliance	Comments
3	Hinges	Ball bearing hinge with five knuckles and one leaf tapped with a non-rising removable steel pin with button tip and plug.	4-1/2" x 4 1/2"	26D	Grade 1 ANSI/BHMA A156.1	
1	Mortise	Privacy, Bedroom Or Bath Lockset		26D	ANSI/BHMA: Certified ANSI/BHMA A156.13, Series	Latchbolt retracted by knob/lever either side.

	lock				1000, Operational Grade 1 UL-cUL: UL/cUL fire rated up to 3 hours Backset: 2-3/4" Latchbolt: 3/4" stainless steel throw	Deadbolt operated by thumbturn inside. When the deadbolt is projected, outside knob/lever is automatically locked. In emergency, deadbolt may be unlocked from outside by E203 emergency key, supplied.
1	Door closer	Fully adjustable door closer	1-1/4" diameter piston	Adjustable closing force range from size 1 - 6 High impact full plastic cover secured by machine screws All weather hydraulic fluid	ANSI/BHMA A156.4, Grade 1 Americans with Disabilities Act (ADA) Compliant ICC A117.1 Compliant UL-cUL Fire-Rated Up to 3 Hours	10-year limited warranty T- stride Curved LIP

END OF SECTION 087111

SECTION 092216 - NON-STRUCTURAL METAL FRAMING

PART 1 - GENERAL

1.1 SUMMARY

- A. Section Includes:
 - 1. Framing systems.
 - 2. Suspension systems.

1.2 ACTION SUBMITTALS

- A. Product Data: For each product.

1.3 INFORMATIONAL SUBMITTALS

- A. Product Certificates: For each type of code-compliance certification for studs and tracks.
- B. Evaluation reports for high-strength steel studs and tracks firestop tracks post-installed anchors and power-actuated fasteners, when applicable.

1.4 QUALITY ASSURANCE

- A. Code-Compliance Certification of Studs and Tracks: Provide documentation that framing members are certified according to the product-certification program of the Steel Framing Industry Association.

PART 2 - PRODUCTS

2.1 PERFORMANCE REQUIREMENTS

- A. Fire-Test-Response Characteristics: For fire-resistance-rated assemblies that incorporate non-load-bearing steel framing, provide materials and construction identical to those tested in assembly indicated, in accordance with ASTM E119 by an independent testing agency.
- B. STC-Rated Assemblies: For STC-rated assemblies, provide materials and construction identical to those tested in assembly indicated on Drawings, in accordance with ASTM E90 and classified in accordance with ASTM E413 by an independent testing agency.

2.2 FRAMING SYSTEMS

- A. Framing Members, General: Comply with ASTM C645 for conditions indicated.

1. Steel Sheet Components: Comply with AISI S220 requirements for metal unless otherwise indicated
2. Protective Coating: Comply with AISI S220; ASTM A653/A653M, G40 (Z120); or coating with equivalent corrosion resistance. Galvannealed products are unacceptable.
 - a. Coating demonstrates equivalent corrosion resistance with an evaluation report acceptable to authorities having jurisdiction.

B. Studs and Track: AISI S220.

1. Minimum Base-Steel Thickness: 0.0296 inch (0.752 mm).
2. Depth: 1-5/8 inches (41 mm).

2.3 SUSPENSION SYSTEMS

A. Tie Wire: ASTM A641/A641M, Class 1 zinc coating, soft temper, 0.062-inch- (1.59-mm-) diameter wire, or double strand of 0.048-inch- (1.21-mm-) diameter wire.

B. Hanger Attachments to Concrete:

1. Post-Installed Anchors: Fastener systems with an evaluation report acceptable to authorities having jurisdiction, based on ICC-ES AC193 as appropriate for the substrate.
 - a. Uses: Securing hangers to structure.
 - b. Material for Interior Locations: Carbon-steel components zinc-plated to comply with ASTM B633 or ASTM F1941 (ASTM F1941M), Class Fe/Zn 5, unless otherwise indicated.
 - c. Material for Exterior or Interior Locations and Where Stainless Steel Is Indicated: Alloy Group 1 (A1) stainless steel bolts, ASTM F593 (ASTM F738M), and nuts, ASTM F594 (ASTM F836M).

C. Wire Hangers: ASTM A641/A641M, Class 1 zinc coating, soft temper, 0.16 inch (4.12 mm) in diameter.

D. Carrying Channels (Main Runners): Cold-rolled, commercial-steel sheet with a base-steel thickness of 0.0538 inch (1.367 mm) and minimum 1/2-inch- (13-mm-) wide flanges.

1. Depth: As indicated on Drawings.

E. Furring Channels (Furring Members):

1. Cold-Rolled Channels: 0.0538-inch (1.367-mm) uncoated-steel thickness, with minimum 1/2-inch- (13-mm-) wide flanges, 3/4 inch (19 mm) deep.
2. Steel Studs and Tracks:
 - a. Minimum Base-Steel Thickness: 0.0269 inch (0.683 mm).
 - b. Depth: As indicated on Drawings.

2.4 AUXILIARY MATERIALS

A. General: Provide auxiliary materials that comply with referenced installation standards.

1. Fasteners for Steel Framing: Of type, material, size, corrosion resistance, holding power, and other properties required to fasten steel members to substrates.

PART 3 - EXECUTION

3.1 INSTALLATION, GENERAL

- A. Installation Standard: ASTM C754.
 1. Gypsum Board Assemblies: Also comply with requirements in ASTM C840 that apply to framing installation.
- B. Install framing and accessories plumb, square, and true to line, with connections securely fastened.
- C. Install supplementary framing, and blocking to support fixtures, equipment services, heavy trim, grab bars, toilet accessories, furnishings, or similar construction.
- D. Install bracing at terminations in assemblies.
- E. Do not bridge building control and expansion joints with non-load-bearing steel framing members. Frame both sides of joints independently.

3.2 INSTALLATION OF FRAMING SYSTEMS

- A. Install framing system components according to spacings indicated, but not greater than spacings required by referenced installation standards for assembly types.
- B. Where studs are installed directly against exterior masonry walls or dissimilar metals at exterior walls, install isolation strip between studs and exterior wall.
- C. Install studs so flanges within framing system point in same direction.
- D. Install tracks at floors and overhead supports. Extend framing full height to structural supports or substrates above suspended ceilings except where partitions are indicated to terminate at suspended ceilings. Continue framing around ducts that penetrate partitions above ceiling.
 1. Fire-Resistance-Rated Partitions: Install framing to comply with fire-resistance-rated assembly indicated and support closures and to make partitions continuous from floor to underside of solid structure.
- E. Direct Furring:
 1. Screw to wood framing.
 2. Attach to concrete or masonry with stub nails, screws designed for masonry attachment, or powder-driven fasteners spaced **24 inches (610 mm)** o.c.
- F. Installation Tolerance: Install each framing member so fastening surfaces vary not more than **1/8 inch (3 mm)** from the plane formed by faces of adjacent framing.

3.3 INSTALLATION OF SUSPENSION SYSTEMS

- A. Install suspension system components according to spacings indicated, but not greater than spacings required by referenced installation standards for assembly types.
- B. Isolate suspension systems from building structure where they abut or are penetrated by building structure to prevent transfer of loading imposed by structural movement.
- C. Suspend hangers from building structure as follows:
 - 1. Install hangers plumb and free from contact with insulation or other objects within ceiling plenum that are not part of supporting structural or suspension system.
 - a. Splay hangers only where required to miss obstructions and offset resulting horizontal forces by bracing, countersplaying, or other equally effective means.
 - 2. Wire Hangers: Secure by looping and wire tying, either directly to structures or to inserts, eye screws, or other devices and fasteners that are secure and appropriate for substrate, and in a manner that will not cause hangers to deteriorate or otherwise fail.
 - 3. Flat Hangers: Secure to structure, including intermediate framing members, by attaching to inserts, eye screws, or other devices and fasteners that are secure and appropriate for structure and hanger, and in a manner that will not cause hangers to deteriorate or otherwise fail.
 - 4. Do not attach hangers to steel roof deck.
 - 5. Do not attach hangers to permanent metal forms. Furnish cast-in-place hanger inserts that extend through forms.
 - 6. Do not attach hangers to rolled-in hanger tabs of composite steel floor deck.
 - 7. Do not connect or suspend steel framing from ducts, pipes, or conduit.

3.4 FIELD QUALITY CONTROL

- A. Installation Tolerances: Install suspension systems that are level to within **1/8 inch in 12 feet (3 mm in 3.6 m)** measured lengthwise on each member that will receive finishes and transversely between parallel members that will receive finishes.

END OF SECTION 092216

SECTION 092400 - CEMENT PLASTERING

PART 1 - GENERAL

1.1 SUMMARY

- A. Section Includes:
 - 1. Base-coat cement plaster.
 - 2. Cement plaster finish coats.
 - 3. Accessories.

1.2 ACTION SUBMITTALS

- A. Product data.
- B. Samples: For each type of factory-prepared finish coat and for each color and texture specified.

PART 2 - PRODUCTS

2.1 BASE-COAT CEMENT PLASTER

- A. General: Comply with ASTM C926 for applications indicated.
- B. Base-Coat Mixes for Use over Unit Masonry and Concrete: Single base (scratch) coat for two-coat plasterwork on low-absorption plaster bases as follows:
 - 1. Portland Cement Mix: For cementitious material, mix 1 part portland cement and 0 to 3/4 part lime. Use 2-1/2 to 4 parts aggregate per part of cementitious material.
 - 2. Portland and Masonry Cement Mix: For cementitious material, mix 1 part portland cement and 1 part masonry cement. Use 2-1/2 to 4 parts aggregate per part of cementitious material.
 - 3. Plastic Cement Mix: Use 1 part plastic cement and 2-1/2 to 4 parts aggregate.
- C. Base-Coat Mixes for Use over Unit Masonry and Concrete: Single base (scratch) coat for two-coat plasterwork on high-absorption plaster bases as follows:
 - 1. Portland Cement Mix: For cementitious material, mix 1 part portland cement and 3/4 to 1-1/2 parts lime. Use 2-1/2 to 4 parts aggregate per part of cementitious material.
 - 2. Masonry Cement Mix: Use 1 part masonry cement and 2-1/2 to 4 parts aggregate.
 - 3. Portland and Masonry Cement Mix: For cementitious material, mix 1 part portland cement and 1 part masonry cement. Use 2-1/2 to 4 parts aggregate per part of cementitious material.
 - 4. Plastic Cement Mix: Use 1 part plastic cement and 2-1/2 to 4 parts aggregate.

2.2 CEMENT PLASTER FINISH COATS

A. Job-Mixed Finish-Coat Mixes:

1. Portland Cement Mix: For cementitious materials, mix 1 part portland cement and parts lime. Use 1-1/2 to 3 parts aggregate per part of cementitious material.
2. Masonry Cement Mix: Use 1 part masonry cement and 1-1/2 to 3 parts aggregate.
3. Portland and Masonry Cement Mix: For cementitious materials, mix 1 part portland cement and 1 part masonry cement. Use 1-1/2 to 3 parts aggregate per part of cementitious material.
4. Plastic Cement Mix: Use 1 part plastic cement and 1-1/2 to 3 parts aggregate.

B. Ready-Mixed Finish-Coat Plaster: Mill-mixed portland cement, aggregates, coloring agents, and proprietary ingredients.

1. Color: As selected by Architect from manufacturer's full range.

2.3 ACCESSORIES

A. General: Comply with ASTM C1063, and coordinate depth of trim and accessories with thicknesses and number of plaster coats required.

B. Metal Accessories:

1. Foundation Weep Scream: Fabricated from hot-dip galvanized-steel sheet, ASTM A653/A653M, G60 (Z180) zinc coating.

2.4 PLASTER MATERIALS

A. Portland Cement: ASTM C150/C150M, Type I.

1. Color for Finish Coats: White.

B. Lime: ASTM C206, Type S; or ASTM C207, Type S.

C. Sand Aggregate: ASTM C897.

1. Color for Job-Mixed Finish Coats: White.

2.5 MISCELLANEOUS MATERIALS

A. Water for Mixing and Finishing Plaster: Potable and free of substances capable of affecting plaster set or of damaging plaster, lath, or accessories.

B. Bonding Compound: ASTM C932.

PART 3 - EXECUTION

3.1 INSTALLATION, GENERAL

- A. Prepare smooth, solid substrates for plaster in accordance with ASTM C926.

3.2 APPLICATION OF BASE-COAT CEMENT PLASTER

- A. General: Comply with ASTM C926.
- B. Bonding Compound: Apply on unit masonry and concrete substrates for direct application of plaster.
- C. Walls; Base-Coat Mixes for Use over Metal Lath: For scratch and brown coats, for three-coat plasterwork with **3/4-inch (19-mm)** total thickness, as follows:
 - 1. Portland cement mixes.
- D. Walls; Base-Coat Mix: For base (scratch) coat, for two-coat plasterwork and having **3/8-inch (10-mm)** thickness on masonry **1/4-inch (6-mm)** thickness on concrete, as follows:
 - 1. Portland cement mix.
- E. Ceilings; Base-Coat Mix: For base (scratch) coat, for two-coat plasterwork and having **1/4-inch (6-mm)** thickness on concrete, as follows:
 - 1. Portland cement mix.

3.3 APPLICATION OF CEMENT PLASTER FINISH COATS

- A. Plaster Finish Coats: Apply to provide float finish to match Architect's sample.
- B. Concealed Exterior Plasterwork: Where plaster application is used as a base for adhered finishes, omit finish coat.
- C. Concealed Interior Plasterwork:
 - 1. Where plaster application is concealed behind built-in cabinets, similar furnishings, and equipment, apply finish coat.
 - 2. Where plaster application is concealed above suspended ceilings and in similar locations, omit finish coat.

3.4 REPAIR

- A. Repair or replace work to eliminate cracks, dents, blisters, buckles, crazing and check cracking, dry outs, efflorescence, sweat outs, and similar defects and where bond to substrate has failed.

END OF SECTION 092400

SECTION 099113 - EXTERIOR PAINTING

PART 1 - GENERAL

1.1 SUMMARY

- A. This Section includes surface preparation and the application of paint systems on the following exterior substrates:
 - 1. Concrete.
 - 2. Concrete masonry units (CMU).
 - 3. Steel.
 - 4. Galvanized metal.
 - 5. Aluminum (not anodized or otherwise coated).
 - 6. Wood.
 - 7. Exterior portland cement (stucco).

1.2 SUBMITTALS

- A. Product Data: For each type of product indicated.
- B. Samples for Initial Selection: For each type of topcoat product indicated.

1.3 QUALITY ASSURANCE

- A. MPI Standards:
 - 1. Products: Complying with MPI standards indicated and listed in "MPI Approved Products List."
 - 2. Preparation and Workmanship: Comply with requirements in "MPI Architectural Painting Specification Manual" for products and paint systems indicated.
- B. Mockups: Apply benchmark samples of each paint system indicated and each color and finish selected to verify preliminary selections made under sample submittals and to demonstrate aesthetic effects and set quality standards for materials and execution.
 - 1. Final approval of color selections will be based on benchmark samples.

1.4 DELIVERY, STORAGE, AND HANDLING

- A. Store materials not in use in tightly covered containers in well-ventilated areas with ambient temperatures continuously maintained at not less than 45 deg F (7 deg C).
 - 1. Maintain containers in clean condition, free of foreign materials and residue.
 - 2. Remove rags and waste from storage areas daily.

1.5 PROJECT CONDITIONS

- A. Apply paints only when temperature of surfaces to be painted and ambient air temperatures are between 50 and 95 deg F (10 and 35 deg C).
- B. Do not apply paints in rain, fog, or mist; when relative humidity exceeds 85 percent; at temperatures less than 5 deg F (3 deg C) above the dew point; or to damp or wet surfaces.

PART 2 - PRODUCTS

2.1 MANUFACTURERS

- A. Manufacturers: Subject to compliance with requirements, provide products by one of the following:
 - 1. Benjamin Moore & Co.
 - 2. BLP Mobile Paint Manufacturing.
 - 3. ChemRex.
 - 4. ICI Paints (Glidden).
 - 5. PPG Architectural Finishes, Inc.
 - 6. Sherwin-Williams Company (The).
 - 7. Submit local manufacturer's data and specifications for approval.

2.2 PAINT, GENERAL

- A. Material Compatibility:
 - 1. Provide materials for use within each paint system that are compatible with one another and substrates indicated, under conditions of service and application as demonstrated by manufacturer, based on testing and field experience.
 - 2. For each coat in a paint system, provide products recommended in writing by manufacturers of topcoat for use in paint system and on substrate indicated.
- B. Colors: As selected by Architect from manufacturer's full range.

2.3 BLOCK FILLERS

- A. Interior/Exterior Latex Block Filler: MPI #4.

2.4 PRIMERS/SEALERS

- A. Bonding Primer (Water Based): MPI #17.

2.5 METAL PRIMERS

- A. Alkyd Anticorrosive Metal Primer: MPI #79.
- B. Quick-Drying Alkyd Metal Primer: MPI #76.
- C. Waterborne Galvanized-Metal Primer: MPI #134.
- D. Quick-Drying Primer for Aluminum: MPI #95.

2.6 WOOD PRIMERS

- A. Exterior Latex Wood Primer: MPI #6.

2.7 EXTERIOR LATEX PAINTS

- A. Exterior Latex (Semigloss): MPI #11 (Gloss Level 5).
- B. Exterior Latex (Gloss): MPI #119 (Gloss Level 6, except minimum gloss of 65 units at 60 deg).

PART 3 - EXECUTION

3.1 EXAMINATION

- A. Examine substrates and conditions, with Applicator present, for compliance with requirements for maximum moisture content and other conditions affecting performance of work.
- B. Maximum Moisture Content of Substrates: When measured with an electronic moisture meter as follows:
 - 1. Concrete: 12 percent.
 - 2. Masonry (Clay and CMU): 12 percent.
 - 3. Wood: 15 percent.
 - 4. Plaster: 12 percent.
- C. Verify suitability of substrates, including surface conditions and compatibility with existing finishes and primers.
- D. Begin coating application only after unsatisfactory conditions have been corrected and surfaces are dry.
 - 1. Beginning coating application constitutes Contractor's acceptance of substrates and conditions.

3.2 PREPARATION

- A. Comply with manufacturer's written instructions and recommendations in "MPI Architectural Painting Specification Manual" applicable to substrates and paint systems indicated.
- B. Remove plates, machined surfaces, and similar items already in place that are not to be painted. If removal is impractical or impossible because of size or weight of item, provide surface-applied protection before surface preparation and painting.
 - 1. After completing painting operations, use workers skilled in the trades involved to reinstall items that were removed. Remove surface-applied protection if any.
 - 2. Do not paint over labels of independent testing agencies or equipment name, identification, performance rating, or nomenclature plates.
- C. Clean substrates of substances that could impair bond of paints, including dirt, oil, grease, and incompatible paints and encapsulants.
 - 1. Remove incompatible primers and reprime substrate with compatible primers as required to produce paint systems indicated.
- D. Concrete Substrates: Remove release agents, curing compounds, efflorescence, and chalk. Do not paint surfaces if moisture content or alkalinity of surfaces to be painted exceeds that permitted in manufacturer's written instructions.
- E. Concrete Masonry Substrates: Remove efflorescence and chalk. Do not paint surfaces if moisture content or alkalinity of surfaces to be painted exceeds that permitted in manufacturer's written instructions.
- F. Steel Substrates: Remove rust and loose mill scale. Clean using methods recommended in writing by paint manufacturer.
- G. Galvanized-Metal Substrates: Remove grease and oil residue from galvanized sheet metal fabricated from coil stock by mechanical methods to produce clean, lightly etched surfaces that promote adhesion of subsequently applied paints.
- H. Aluminum Substrates: Remove surface oxidation.
- I. Wood Substrates:
 - 1. Scrape and clean knots, and apply coat of knot sealer before applying primer.
 - 2. Sand surfaces that will be exposed to view, and dust off.
 - 3. Prime edges, ends, faces, undersides, and backsides of wood.
 - 4. After priming, fill holes and imperfections in the finish surfaces with putty or plastic wood filler. Sand smooth when dried.
- J. Plaster Substrates: Do not begin paint application until plaster is fully cured and dry.

3.3 APPLICATION

- A. Apply paints according to manufacturer's written instructions.

1. Use applicators and techniques suited for paint and substrate indicated.
 2. Paint surfaces behind movable items same as similar exposed surfaces. Before final installation, paint surfaces behind permanently fixed items with prime coat only.
- B. Tint each undercoat a lighter shade to facilitate identification of each coat if multiple coats of same material are to be applied. Tint undercoats to match color of topcoat, but provide sufficient difference in shade of undercoats to distinguish each separate coat.
- C. If undercoats or other conditions show through topcoat, apply additional coats until cured film has a uniform paint finish, color, and appearance.
- D. Apply paints to produce surface films without cloudiness, spotting, holidays, laps, brush marks, roller tracking, runs, sags, ropiness, or other surface imperfections. Cut in sharp lines and color breaks.

3.4 CLEANING AND PROTECTION

- A. At end of each workday, remove rubbish, empty cans, rags, and other discarded materials from Project site.
- B. After completing paint application, clean spattered surfaces. Remove spattered paints by washing, scraping, or other methods. Do not scratch or damage adjacent finished surfaces.
- C. Protect work of other trades against damage from paint application. Correct damage to work of other trades by cleaning, repairing, replacing, and refinishing, as approved by Architect, and leave in an undamaged condition.
- D. At completion of construction activities of other trades, touch up and restore damaged or defaced painted surfaces.

3.5 EXTERIOR PAINTING SCHEDULE

- A. Concrete Substrates, Nontraffic Surfaces:
1. Latex System: MPI EXT 3.1A.
 - a. Prime Coat: Exterior latex matching topcoat.
 - b. Intermediate Coat: Exterior latex matching topcoat.
 - c. Topcoat: Exterior latex (semigloss).
- B. CMU Substrates:
1. Latex System: MPI EXT 4.2A.
 - a. Prime Coat: Interior/exterior latex block filler.
 - b. Intermediate Coat: Exterior latex matching topcoat.
 - c. Topcoat: Exterior latex (semigloss).
- C. Steel Substrates:

1. Quick-Drying Enamel System: MPI EXT 5.1A.
 - a. Prime Coat: Quick-drying alkyd metal primer.
 - b. Intermediate Coat: Quick-drying enamel matching topcoat.
 - c. Topcoat: Quick-drying enamel (high gloss).

- D. Galvanized-Metal Substrates:
 1. Latex Over Water-Based Primer System: MPI EXT 5.3H.
 - a. Prime Coat: Waterborne galvanized-metal primer.
 - b. Intermediate Coat: Exterior latex matching topcoat.
 - c. Topcoat: Exterior latex (gloss).

- E. Aluminum Substrates:
 1. Latex System: MPI EXT 5.4H.
 - a. Prime Coat: Quick-drying primer for aluminum.
 - b. Intermediate Coat: Exterior latex matching topcoat.
 - c. Topcoat: Exterior latex (gloss).

- F. Dressed Lumber Substrates: Including architectural woodwork, doors and frames.
 1. Latex System: MPI EXT 6.3L.
 - a. Prime Coat: Exterior latex wood primer.
 - b. Intermediate Coat: Exterior latex matching topcoat.
 - c. Topcoat: Exterior latex (gloss).

END OF SECTION 099113

SECTION 099123 - INTERIOR PAINTING

PART 1 - GENERAL

1.1 SUMMARY

- A. This Section includes surface preparation and the application of paint systems on the following interior substrates:
 - 1. Concrete.
 - 2. Concrete masonry units (CMU).
 - 3. Steel.
 - 4. Galvanized metal.
 - 5. Aluminum (not anodized or otherwise coated).
 - 6. Wood.
 - 7. Plaster.

1.2 SUBMITTALS

- A. Product Data: For each type of product indicated.
- B. Samples for Initial Selection: For each type of topcoat product indicated.
- C. Product List: For each product indicated, include the following:
 - 1. Cross-reference to paint system and locations of application areas.
 - 2. Printout of current "MPI Approved Products List" for each product category specified in Part 2, with the proposed product highlighted.

1.3 QUALITY ASSURANCE

- A. MPI Standards:
 - 1. Products: Complying with MPI standards indicated and listed in "MPI Approved Products List."
 - 2. Preparation and Workmanship: Comply with requirements in "MPI Architectural Painting Specification Manual" for products and paint systems indicated.
- B. Mockups: Apply benchmark samples of each paint system indicated and each color and finish selected to verify preliminary selections made under sample submittals and to demonstrate aesthetic effects and set quality standards for materials and execution.
 - 1. Final approval of color selections will be based on benchmark samples.

1.4 DELIVERY, STORAGE, AND HANDLING

- A. Store materials not in use in tightly covered containers in well-ventilated areas with ambient temperatures continuously maintained at not less than 45 deg F (7 deg C).
 - 1. Maintain containers in clean condition, free of foreign materials and residue.
 - 2. Remove rags and waste from storage areas daily.

1.5 PROJECT CONDITIONS

- A. Apply paints only when temperature of surfaces to be painted and ambient air temperatures are between 50 and 95 deg F (10 and 35 deg C).
- B. Do not apply paints when relative humidity exceeds 85 percent; at temperatures less than 5 deg F (3 deg C) above the dew point; or to damp or wet surfaces.

PART 2 - PRODUCTS

2.1 MANUFACTURERS

- A. Available Manufacturers: Subject to compliance with requirements, manufacturers offering products that may be incorporated into the Work include, but are not limited to, the following:
 - 1. Benjamin Moore & Co.
 - 2. BLP Mobile Paint Manufacturing.
 - 3. ICI Paints (Glidden).
 - 4. PPG Architectural Finishes, Inc.
 - 5. Sherwin-Williams Company (The).
 - 6. Submit local manufacturer's data and specifications for approval.

2.2 PAINT, GENERAL

- A. Material Compatibility:
 - 1. Provide materials for use within each paint system that are compatible with one another and substrates indicated, under conditions of service and application as demonstrated by manufacturer, based on testing and field experience.
 - 2. For each coat in a paint system, provide products recommended in writing by manufacturers of topcoat for use in paint system and on substrate indicated.
- B. Chemical Components of Field-Applied Interior Paints and Coatings: Provide topcoat paints and anti-corrosive and anti-rust paints applied to ferrous metals that comply with the following chemical restrictions; these requirements do not apply to paints and coatings that are applied in a fabrication or finishing shop:
 - 1. Restricted Components: Paints and coatings shall not contain any of the following:
 - a. Acrolein.

- b. Acrylonitrile.
- c. Antimony.
- d. Benzene.
- e. Butyl benzyl phthalate.
- f. Cadmium.
- g. Di (2-ethylhexyl) phthalate.
- h. Di-n-butyl phthalate.
- i. Di-n-octyl phthalate.
- j. 1,2-dichlorobenzene.
- k. Diethyl phthalate.
- l. Dimethyl phthalate.
- m. Ethylbenzene.
- n. Formaldehyde.
- o. Hexavalent chromium.
- p. Isophorone.
- q. Lead.
- r. Mercury.
- s. Methyl ethyl ketone.
- t. Methyl isobutyl ketone.
- u. Methylene chloride.
- v. Naphthalene.
- w. Toluene (methylbenzene).
- x. 1,1,1-trichloroethane.
- y. Vinyl chloride.

C. Colors: As selected by Architect from manufacturer's full range.

2.3 BLOCK FILLERS

A. Interior/Exterior Latex Block Filler: MPI #4.

2.4 PRIMERS/SEALERS

A. Interior Latex Primer/Sealer: MPI #50.

2.5 METAL PRIMERS

- A. Quick-Drying Alkyd Metal Primer: MPI #76.
- B. Rust-Inhibitive Primer (Water Based): MPI #107.
- C. Waterborne Galvanized-Metal Primer: MPI #134.
- D. Quick-Drying Primer for Aluminum: MPI #95.

2.6 WOOD PRIMERS

A. Interior Latex-Based Wood Primer: MPI #39.

2.7 LATEX PAINTS

- A. Interior Latex (Semigloss): MPI #54 (Gloss Level 5).

2.8 QUICK-DRYING ENAMELS

- A. Quick-Drying Enamel (High Gloss): MPI #96 (Gloss Level 7).

2.9 ALUMINUM PAINT

- A. Aluminum Paint: MPI #1.

PART 3 - EXECUTION

3.1 EXAMINATION

- A. Examine substrates and conditions, with Applicator present, for compliance with requirements for maximum moisture content and other conditions affecting performance of work.
- B. Maximum Moisture Content of Substrates: When measured with an electronic moisture meter as follows:
 - 1. Concrete: 12 percent.
 - 2. Masonry (Clay and CMU): 12 percent.
 - 3. Wood: 15 percent.
 - 4. Plaster: 12 percent.
- C. Verify suitability of substrates, including surface conditions and compatibility with existing finishes and primers.
- D. Begin coating application only after unsatisfactory conditions have been corrected and surfaces are dry.
 - 1. Beginning coating application constitutes Contractor's acceptance of substrates and conditions.

3.2 PREPARATION

- A. Comply with manufacturer's written instructions and recommendations in "MPI Architectural Painting Specification Manual" applicable to substrates indicated.
- B. Remove plates, machined surfaces, and similar items already in place that are not to be painted. If removal is impractical or impossible because of size or weight of item, provide surface-applied protection before surface preparation and painting.
 - 1. After completing painting operations, use workers skilled in the trades involved to reinstall items that were removed. Remove surface-applied protection if any.

2. Do not paint over labels of independent testing agencies or equipment name, identification, performance rating, or nomenclature plates.
- C. Clean substrates of substances that could impair bond of paints, including dirt, oil, grease, and incompatible paints and encapsulants.
 1. Remove incompatible primers and reprime substrate with compatible primers as required to produce paint systems indicated.
- D. Concrete Substrates: Remove release agents, curing compounds, efflorescence, and chalk. Do not paint surfaces if moisture content or alkalinity of surfaces to be painted exceeds that permitted in manufacturer's written instructions.
- E. Concrete Masonry Substrates: Remove efflorescence and chalk. Do not paint surfaces if moisture content or alkalinity of surfaces to be painted exceeds that permitted in manufacturer's written instructions.
- F. Steel Substrates: Remove rust and loose mill scale. Clean using methods recommended in writing by paint manufacturer.
- G. Galvanized-Metal Substrates: Remove grease and oil residue from galvanized sheet metal fabricated from coil stock by mechanical methods to produce clean, lightly etched surfaces that promote adhesion of subsequently applied paints.
- H. Aluminum Substrates: Remove surface oxidation.
- I. Wood Substrates:
 1. Scrape and clean knots, and apply coat of knot sealer before applying primer.
 2. Sand surfaces that will be exposed to view, and dust off.
 3. Prime edges, ends, faces, undersides, and backsides of wood.
 4. After priming, fill holes and imperfections in the finish surfaces with putty or plastic wood filler. Sand smooth when dried.
- J. Plaster Substrates: Do not begin paint application until plaster is fully cured and dry.

3.3 APPLICATION

- A. Apply paints according to manufacturer's written instructions.
 1. Use applicators and techniques suited for paint and substrate indicated.
 2. Paint surfaces behind movable equipment and furniture same as similar exposed surfaces. Before final installation, paint surfaces behind permanently fixed equipment or furniture with prime coat only.
 3. Paint front and backsides of access panels, removable or hinged covers, and similar hinged items to match exposed surfaces.
- B. Tint each undercoat a lighter shade to facilitate identification of each coat if multiple coats of same material are to be applied. Tint undercoats to match color of topcoat, but provide sufficient difference in shade of undercoats to distinguish each separate coat.

- C. If undercoats or other conditions show through topcoat, apply additional coats until cured film has a uniform paint finish, color, and appearance.
- D. Apply paints to produce surface films without cloudiness, spotting, holidays, laps, brush marks, roller tracking, runs, sags, ropiness, or other surface imperfections. Cut in sharp lines and color breaks.

3.4 CLEANING AND PROTECTION

- A. At end of each workday, remove rubbish, empty cans, rags, and other discarded materials from Project site.
- B. After completing paint application, clean spattered surfaces. Remove spattered paints by washing, scraping, or other methods. Do not scratch or damage adjacent finished surfaces.
- C. Protect work of other trades against damage from paint application. Correct damage to work of other trades by cleaning, repairing, replacing, and refinishing, as approved by Architect, and leave in an undamaged condition.
- D. At completion of construction activities of other trades, touch up and restore damaged or defaced painted surfaces.

3.5 INTERIOR PAINTING SCHEDULE

- A. Concrete Substrates, Nontraffic Surfaces:
 - 1. Latex System: MPI INT 3.1E.
 - a. Prime Coat: Interior latex matching topcoat.
 - b. Intermediate Coat: Interior latex matching topcoat.
 - c. Topcoat: Interior latex (semigloss).
- B. CMU Substrates:
 - 1. Latex System: MPI INT 4.2A.
 - a. Prime Coat: Interior/exterior latex block filler.
 - b. Intermediate Coat: Interior latex matching topcoat.
 - c. Topcoat: Interior latex (semigloss).
- C. Steel Substrates:
 - 1. Quick-Drying Enamel System: MPI INT 5.1A.
 - a. Prime Coat: Quick-drying alkyd metal primer.
 - b. Intermediate Coat: Quick-drying enamel matching topcoat.
 - c. Topcoat: Quick-drying enamel (high gloss).
- D. Galvanized-Metal Substrates:

1. Water-Based Dry-Fall System: MPI INT 5.3H.
 - a. Prime Coat: Waterborne dry fall.
 - b. Topcoat: Waterborne dry fall.

- E. Aluminum (Not Anodized or Otherwise Coated) Substrates:
 1. Aluminum Paint System: MPI INT 5.4D.
 - a. Prime Coat: Vinyl wash primer.
 - b. Intermediate Coat: Aluminum paint.
 - c. Topcoat: Aluminum paint.

- F. Dressed Lumber Substrates: Including architectural woodwork, doors and frames.
 1. Latex System: MPI INT 6.3T.
 - a. Prime Coat: Interior latex-based wood primer.
 - b. Intermediate Coat: Interior latex matching topcoat.
 - c. Topcoat: Interior latex (gloss).

- G. Wood Panel Substrates: Including hardboard.
 1. Latex System: MPI INT 6.4R.
 - a. Prime Coat: Interior latex-based wood primer.
 - b. Intermediate Coat: Interior latex matching topcoat.
 - c. Topcoat: Interior latex (gloss).

- H. Plaster Substrates:
 1. Latex System: MPI INT 9.2A.
 - a. Prime Coat: Interior latex primer/sealer.
 - b. Intermediate Coat: Interior latex matching topcoat.
 - c. Topcoat: Interior latex (semigloss).

END OF SECTION 099123

SECTION 099653 - ELASTOMERIC COATINGS

PART 1 - GENERAL

1.1 SUMMARY

A. Section Includes:

1. Elastomeric coatings.

1.2 ACTION SUBMITTALS

A. Product data.

- B. Samples: For each type of elastomeric coating indicated and in each color and gloss.

1.3 WARRANTY

- A. Special Warranty: Manufacturer's standard form in which manufacturer agrees to repair or replace elastomeric coatings that fail within specified warranty period.

PART 2 - PRODUCTS

2.1 ELASTOMERIC COATINGS

A. Material Compatibility:

1. Materials for use within each paint system are compatible with one another and substrates indicated, under conditions of service and application as demonstrated by manufacturer, based on testing and field experience.
2. For each coat in a paint system, products are recommended in writing by manufacturers of topcoat for use in paint system and on substrate indicated.

B. Colors: As selected by Architect from manufacturer's full range.

- C. Crack Fillers: Elastomeric coating manufacturer's recommended, factory-formulated crack fillers or sealants, including crack filler primers, compatible with substrate and other materials indicated.

D. Primer: Elastomeric coating manufacturer's recommended, factory-formulated, alkali-resistant primer compatible with substrate and other materials indicated.

- E. Concrete Unit Masonry Block Filler: Elastomeric coating manufacturer's recommended, factory-formulated, high-performance latex block filler compatible with substrate and other materials indicated.

PART 3 - EXECUTION

3.1 EXAMINATION

- A. Examine substrates and conditions, with Applicator present, for compliance with manufacturer's requirements for maximum moisture content, alkalinity, and other conditions affecting performance of work.
- B. Begin coating only when moisture content of substrate is 12 percent or less when measured with an electronic moisture meter.

3.2 PREPARATION

- A. Comply with manufacturer's written instructions applicable to substrates and coating systems indicated.
- B. Remove hardware and hardware accessories, plates, machined surfaces, light fixtures, and similar items already installed that are not to be coated. If removal is impractical or impossible because of size or weight of item, provide surface-applied protection before surface preparation and coating.
 - 1. After completing coating operations, use workers skilled in the trades involved to reinstall items that were removed. Remove surface-applied protection if any.
- C. Crack Repair: Fill cracks in accordance with manufacturer's written instructions before coating surfaces.

3.3 APPLICATION OF ELASTOMERIC COATINGS

- A. Apply elastomeric coatings in accordance with manufacturer's written instructions.
- B. Primers: Apply at a rate to ensure complete coverage.
- C. Block Fillers: Apply at a rate to ensure complete coverage with pores filled.
- D. Elastomeric Finish Coat(s): Manufacturer's recommended number of coats and total dry film thickness for condition of substrate.

3.4 ELASTOMERIC COATING SCHEDULE

- A. Concrete Substrates:
 - 1. Elastomeric Coating System:
 - a. Prime Coat: As recommended in writing by topcoat manufacturer.
 - b. Intermediate Coat: As recommended in writing by topcoat manufacturer.
 - c. Topcoat: Elastomeric, pigmented, exterior, water-based, flat coating.

B. Concrete Unit Masonry Substrates:

1. Elastomeric Coating System:

- a. Prime Coat: As recommended in writing by topcoat manufacturer.
- b. Block Filler: As recommended in writing by topcoat manufacturer.
- c. Intermediate Coat: As recommended in writing by topcoat manufacturer.
- d. Topcoat: Elastomeric, pigmented, exterior, water-based, flat coating.

END OF SECTION 099653

SECTION 220500 - COMMON WORK RESULTS FOR PLUMBING

PART 1 - GENERAL

1.1 SUMMARY

- A. Section Includes:
 - 1. Sleeves without waterstop.
 - 2. Sleeves with waterstop.
 - 3. Sleeve-seal systems.
 - 4. Grout.
 - 5. Silicone sealants.
 - 6. Escutcheons.

1.2 ACTION SUBMITTALS

- A. Product data.
- B. Delegated Design Submittals: For each anchor and alignment guide, including analysis data, signed and sealed by the qualified professional engineer responsible for their preparation.
 - 1. Design Calculations: Calculate requirements for thermal expansion of piping systems and for selecting and designing expansion joints, loops, and swing connections.
 - 2. Anchor Details: Detail fabrication of each anchor indicated. Show dimensions and methods of assembly and attachment to building structure.
 - 3. Alignment Guide Details: Detail field assembly and attachment to building structure.
 - 4. Schedule: Indicate type, manufacturer's number, size, material, pressure rating, end connections, and location for each expansion joint.

1.3 INFORMATIONAL SUBMITTALS

- A. Welding certificates.
- B. Field quality-control reports.

1.4 CLOSEOUT SUBMITTALS

- A. Operation and maintenance data.

1.5 QUALITY ASSURANCE

- A. Welding Qualifications: Qualify procedures and personnel in accordance with AWS D1.1/D1.1M.

- B. Pipe and Pressure-Vessel Welding Qualifications: Qualify procedures and operators in accordance with 2021 ASME Boiler and Pressure Vessel Code, Section IX.

PART 2 - PRODUCTS

2.1 PERFORMANCE REQUIREMENTS

- A. Domestic water for plumbing piping intended to convey or dispense water for human consumption are to comply with the U.S. Safe Drinking Water Act, with requirements of authorities having jurisdiction, and with NSF 61 and NSF 372, or be certified in compliance with NSF 61 and NSF 372 by an ANSI-accredited third-party certification body, in that the weighted average lead content at wetted surfaces is less than or equal to 0.25 percent.
- B. Compatibility: Provide products suitable for piping service fluids, materials, working pressures, and temperatures.
- C. Capability: Provide products and installations to accommodate maximum axial movement as scheduled or indicated on Drawings.

2.2 SLEEVES AND SLEEVE SEALS

- A. Sleeves without Waterstop:
 - 1. Cast-Iron Pipe Sleeves: Cast or fabricated of cast or ductile iron, with plain ends.
 - 2. Steel Pipe Sleeves: ASTM A53/A53M, Type E, Grade B, Schedule 40, hot-dip galvanized, with plain ends.
 - 3. Steel Sheet Sleeves: ASTM A653/A653M, 24 gauge (0.6 mm) minimum thickness; hot-dip galvanized, round tube closed with welded longitudinal joint.
- B. Sleeves with Waterstop:
 - 1. Description: Manufactured stainless steel, sleeve-type, waterstop assembly made for imbedding in concrete slab or wall.
- C. Sleeve-Seal Systems:
 - 1. Description: Modular sealing-element unit, designed for field assembly, for filling annular space between piping and sleeve.
 - a. Hydrostatic Seal: 20 psig (137 kPa) minimum.
 - b. Sealing Elements: EPDM-rubber interlocking links shaped to fit surface of pipe. Include type and number required for pipe material and size of pipe.
 - c. Pressure Plates: Stainless steel.
 - d. Connecting Bolts and Nuts: Stainless steel of length required to secure pressure plates to sealing elements.
- D. Grout:
 - 1. Description: Nonshrink, for interior and exterior sealing openings in non-fire-rated walls or floors.

2. Standard: ASTM C1107/C1107M, Grade B, post-hardening and volume-adjusting, dry, hydraulic-cement grout.
3. Design Mix: 5000 psi (34.5 MPa), 28-day compressive strength.
4. Packaging: Premixed and factory packaged.

E. Silicone Sealants:

1. Silicone Sealant, S, NS, 25, NT: Single-component, nonsag, plus 25 percent and minus 25 percent movement capability, nontraffic-use, neutral-curing silicone joint sealant.
 - a. Standard: ASTM C920, Type S, Grade NS, Class 25, Use NT.
2. Silicone Sealant, S, P, T, NT: Single-component, 25, pourable, movement capability, traffic- and nontraffic-use, neutral-curing silicone joint sealant.
 - a. Standard: ASTM C920, Type S, Grade P, Class 25, Uses T and NT.

2.3 ESCUTCHEONS

A. Escutcheon Types:

1. One-Piece, Steel Type: With polished brass finish and setscrew fastener.
2. One-Piece, Deep-Pattern Type: Deep-drawn, box-shaped brass with polished, chrome-plated finish and spring-clip fasteners.
3. One-Piece, Stamped-Steel Type: With polished, chrome-plated finish and spring-clip fasteners.
4. Split-Plate, Stamped-Steel Type: With polished, chrome-plated finish; concealed and exposed-rivet hinge; and spring-clip fasteners.

B. Floor Plates:

1. Split Floor Plates: Cast brass with concealed hinge.

PART 3 - EXECUTION

3.1 INSTALLATION OF SLEEVES - GENERAL

- A. Install sleeves for piping passing through penetrations in floors, partitions, roofs, and walls.
- B. For sleeves that will have sleeve-seal system installed, select sleeves of size large enough to provide 1-inch (25-mm) annular clear space between piping and concrete slabs and walls.
 1. Sleeves are not required for core-drilled holes.
- C. Install sleeves in concrete floors, concrete roof slabs, and concrete walls as new slabs and walls are constructed.
 1. Cut sleeves to length for mounting flush with both surfaces.
 - a. Exception: Extend sleeves installed in floors of mechanical equipment areas or other wet areas 2 inches (50 mm) above finished floor level.

2. Using grout or silicone sealant, seal the space outside of sleeves in floors/slabs/walls without sleeve-seal system. Select to maintain fire resistance of floor/slab/wall.

D. Install sleeves for pipes passing through interior partitions.

1. Cut sleeves to length for mounting flush with both surfaces.
2. Install sleeves that are large enough to provide 1/4-inch (6.4-mm) annular clear space between sleeve and pipe or pipe insulation.
3. Seal annular space between sleeve and piping or piping insulation; use joint sealants that joint sealant manufacturer's literature indicates is appropriate for size, depth, and location of joint.

3.2 INSTALLATION OF SLEEVES WITH WATERSTOP

- A. Install sleeve with waterstop as new walls and slabs are constructed.
- B. Assemble fitting components of length to be flush with both surfaces of concrete slabs and walls. Position waterstop flange centered across width of concrete slab or wall.
- C. Secure nailing flanges to wooden concrete forms.
- D. Using grout or silicone sealant, seal space around outside of sleeves. Select to maintain fire resistance of floor/slab/wall.

3.3 INSTALLATION OF SLEEVE-SEAL SYSTEMS

- A. Install sleeve-seal systems in sleeves in exterior concrete walls and slabs-on-grade at service piping entries into building, and passing through exterior walls.
- B. Select type, size, and number of sealing elements required for piping material and size and for sleeve ID or hole size. Assemble sleeve-seal system components, and install in annular space between piping and sleeve. Tighten bolts against pressure plates that cause sealing elements to expand and make a watertight seal.

3.4 INSTALLATION OF ESCUTCHEONS

- A. Install escutcheons for piping penetrations of walls, ceilings, and finished floors.
- B. Install escutcheons with ID to closely fit around pipe, tube, and insulation of insulated piping and with OD that completely covers opening.

3.5 FIELD QUALITY CONTROL

- A. Sleeves and Sleeve Seals:
 1. Perform the following tests and inspections:

- a. Leak Test: After allowing for a full cure, test sleeves and sleeve seals for leaks. Repair leaks and retest until no leaks exist.
 - b. Sleeves and sleeve seals will be considered defective if they do not pass tests and inspections.
2. Prepare test and inspection reports.
- B. Escutcheons:
1. Using new materials, replace broken and damaged escutcheons and floor plates.

3.6 SLEEVES APPLICATION

- A. Use sleeves and sleeve seals for the following piping-penetration applications:
1. Exterior Concrete Walls above and below Grade:
 - a. Sleeves with waterstops.
 - 1) Select sleeve size to allow for 1-inch (25-mm) annular clear space between piping and sleeve for installing sleeve-seal system.
 2. Concrete Slabs-on-Grade:
 - a. Sleeves with waterstops.
 - 1) Select sleeve size to allow for 1-inch (25-mm) annular clear space between piping and sleeve for installing sleeve-seal system.
 3. Concrete Slabs above Grade:
 - a. Sleeves with waterstops.
 4. Interior Wall and Partitions:
 - a. Sleeves without waterstops.

3.7 ESCUTCHEONS APPLICATION

- A. Escutcheons for New Piping and Relocated Existing Piping:
1. Piping with Fitting or Sleeve Protruding from Wall: One piece, deep pattern.
 2. Chrome-Plated Piping: One piece, or split-casting brass with polished, chrome-plated finish.
 - a. One piece, steel with polished brass finish.
 - b. One piece, stamped steel or split plate, stamped steel with concealed hinge or split plate, stamped steel with exposed-rivet hinge with polished, chrome-plated finish.
- B. Escutcheons for Existing Piping to Remain:

1. Chrome-Plated Piping: Split casting, stamped steel with concealed or exposed-rivet hinge with polished, chrome-plated finish.
 2. Bare Piping at Wall and Floor Penetrations in Finished Spaces: Split plate, stamped steel with concealed or exposed-rivet hinge with polished, chrome-plated finish.
 3. Bare Piping at Ceiling Penetrations in Finished Spaces: Split plate, stamped steel with concealed or exposed-rivet hinge with polished, chrome-plated finish.
 4. Bare Piping in Unfinished Service Spaces: Split plate, stamped steel with concealed or exposed-rivet hinge with polished, chrome-plated finish.
 5. Bare Piping in Equipment Rooms: Split plate, stamped steel with concealed or exposed-rivet hinge with polished, chrome-plated finish.
- C. Install floor plates for piping penetrations of equipment-room floors.
- D. Install floor plates with ID to closely fit around pipe, tube, and insulation of piping and with OD that completely covers opening.
1. New Piping and Relocated Existing Piping: One piece, floor plate.
 2. Existing Piping: Split floor plate.

END OF SECTION 220500

SECTION 220517 - SLEEVES AND SLEEVE SEALS FOR PLUMBING PIPING

PART 1 - GENERAL

1.1 SUMMARY

- A. Section Includes:
 - 1. Sleeves without waterstop.
 - 2. Sleeves with waterstop.
 - 3. Sleeve-seal systems.
 - 4. Grout.
 - 5. Silicone sealants.

1.2 ACTION SUBMITTALS

- A. Product Data: For each type of product.

1.3 INFORMATIONAL SUBMITTALS

- A. Field quality-control reports.

PART 2 - PRODUCTS

2.1 SLEEVES WITHOUT WATERSTOP

- A. Cast-Iron Pipe Sleeves: Cast or fabricated of cast or ductile iron and equivalent to ductile-iron pressure pipe, with plain ends.
- B. Steel Pipe Sleeves: ASTM A53/A53M, Type E, Grade B, Schedule 40, hot-dip galvanized, with plain ends.
- C. Steel Sheet Sleeves: ASTM A653/A653M, 0.0239-inch (0.6-mm) minimum thickness; hot-dip galvanized, round tube closed with welded longitudinal joint.
- D. PVC Pipe Sleeves: ASTM D1785, Schedule 40.

2.2 SLEEVES WITH WATERSTOP

- A. Description: Manufactured stainless steel, sleeve-type, waterstop assembly made for imbedding in concrete slab or wall.

- B. Description: Manufactured, Dura-coated or Duco-coated cast-iron sleeve with integral clamping flange for use in waterproof floors and roofs. Include clamping ring, bolts, and nuts for membrane flashing.
 - 1. Underdeck Clamp: Clamping ring with setscrews.

2.3 SLEEVE-SEAL SYSTEMS

- A. Description: Modular sealing-element unit, designed for field assembly, for filling annular space between piping and sleeve.
 - 1. Designed to form a hydrostatic seal of 20 psig (137 kPa) minimum.
 - 2. Sealing Elements: EPDM-rubber interlocking links shaped to fit surface of pipe. Include type and number required for pipe material and size of pipe.
 - 3. Pressure Plates: Stainless steel.
 - 4. Connecting Bolts and Nuts: Stainless steel of length required to secure pressure plates to sealing elements.

2.4 GROUT

- A. Description: Nonshrink, for interior and exterior sealing openings in non-fire-rated walls or floors.
- B. Standard: ASTM C1107/C1107M, Grade B, post-hardening and volume-adjusting, dry, hydraulic-cement grout.
- C. Design Mix: 5000 psi (34.5 MPa), 28-day compressive strength.
- D. Packaging: Premixed and factory packaged.

2.5 SILICONE SEALANTS

- A. Silicone, S, NS, 25, NT: Single-component, nonsag, plus 25 percent and minus 25 percent movement capability, nontraffic-use, neutral-curing silicone joint sealant.
 - 1. Standard: ASTM C920, Type S, Grade NS, Class 25, Use NT.
- B. Silicone, S, P, T, NT: Single-component, 25, pourable, plus 25 percent and minus 25 percent movement capability, traffic- and nontraffic-use, neutral-curing silicone joint sealant.
 - 1. Standard: ASTM C920, Type S, Grade P, Class 25, Uses T and NT.

PART 3 - EXECUTION

3.1 INSTALLATION OF SLEEVES - GENERAL

- A. Install sleeves for piping passing through penetrations in floors, partitions, roofs, and walls.

- B. For sleeves that will have sleeve-seal system installed, select sleeves of size large enough to provide 1-inch (25-mm) annular clear space between piping and concrete slabs and walls.
 - 1. Sleeves are not required for core-drilled holes.
- C. Install sleeves in concrete floors, concrete roof slabs, and concrete walls as new slabs and walls are constructed.
 - 1. Permanent sleeves are not required for holes in slabs formed by molded-PE or -PP sleeves.
 - 2. Cut sleeves to length for mounting flush with both surfaces.
 - a. Exception: Extend sleeves installed in floors of mechanical equipment areas or other wet areas 2 inches (50 mm) above finished floor level.
 - 3. Using grout or silicone sealant, seal the space outside of sleeves in slabs and walls without sleeve-seal system.
- D. Install sleeves for pipes passing through interior partitions.
 - 1. Cut sleeves to length for mounting flush with both surfaces.
 - 2. Install sleeves that are large enough to provide 1/4-inch (6.4-mm) annular clear space between sleeve and pipe or pipe insulation.
 - 3. Seal annular space between sleeve and piping or piping insulation; use joint sealants appropriate for size, depth, and location of joint.
- E. Fire-Resistance-Rated Penetrations, Horizontal Assembly Penetrations, and Smoke Barrier Penetrations: Maintain indicated fire or smoke rating of walls, partitions, ceilings, and floors at pipe penetrations. Seal pipe penetrations with fire- and smoke-stop materials.

3.2 INSTALLATION OF SLEEVES WITH WATERSTOP

- A. Install sleeve with waterstop as new walls and slabs are constructed.
- B. Assemble fitting components of length to be flush with both surfaces of concrete slabs and walls. Position waterstop flange to be centered in concrete slab or wall.
- C. Secure nailing flanges to concrete forms.
- D. Using grout or silicone sealant, seal the space around outside of sleeves.

3.3 INSTALLATION OF SLEEVE-SEAL SYSTEMS

- A. Install sleeve-seal systems in sleeves in exterior concrete walls and slabs-on-grade at service piping entries into building, and passing through exterior walls.
- B. Select type, size, and number of sealing elements required for piping material and size and for sleeve ID or hole size. Position piping in center of sleeve. Center piping in penetration, assemble sleeve-seal system components, and install in annular space between piping and

sleeve. Tighten bolts against pressure plates that cause sealing elements to expand and make a watertight seal.

3.4 FIELD QUALITY CONTROL

A. Perform the following tests and inspections:

1. Leak Test: After allowing for a full cure, test sleeves and sleeve seals for leaks. Repair leaks and retest until no leaks exist.
2. Sleeves and sleeve seals will be considered defective if they do not pass tests and inspections.

B. Prepare test and inspection reports.

3.5 SLEEVE SCHEDULE

A. Use sleeves and sleeve seals for the following piping-penetration applications:

1. Exterior Concrete Walls above and below Grade:
 - a. Sleeves with waterstops.
 - 1) Select sleeve size to allow for 1-inch (25-mm) annular clear space between piping and sleeve for installing sleeve-seal system.
2. Concrete Slabs-on-Grade:
 - a. Sleeves with waterstops.
 - 1) Select sleeve size to allow for 1-inch (25-mm) annular clear space between piping and sleeve for installing sleeve-seal system.
3. Concrete Slabs above Grade:
 - a. Sleeves with waterstops.
4. Interior Partitions:
 - a. Sleeves without waterstops.

END OF SECTION 220517

SECTION 220529 - HANGERS AND SUPPORTS FOR PLUMBING PIPING AND EQUIPMENT

PART 1 - GENERAL

1.1 SUMMARY

- A. Section Includes:
 - 1. Metal pipe hangers and supports.
 - 2. Fastener systems.
 - 3. Pipe-positioning systems.

1.2 ACTION SUBMITTALS

- A. Product Data: For each type of product.
- B. Shop Drawings: Signed and sealed by a qualified professional engineer. Show fabrication and installation details and include calculations.
- C. Delegated Design Submittals: For trapeze hangers indicated to comply with performance requirements and design criteria, including analysis data signed and sealed by the qualified professional engineer responsible for their preparation.

1.3 INFORMATIONAL SUBMITTALS

- A. Welding certificates.

1.4 QUALITY ASSURANCE

- A. Structural-Steel Welding Qualifications: Qualify procedures and personnel according to AWS D1.1/D1.1M.
- B. Pipe Welding Qualifications: Qualify procedures and operators according to "2015 ASME Boiler and Pressure Vessel Code, Section IX."

PART 2 - PRODUCTS

2.1 PERFORMANCE REQUIREMENTS

- A. Delegated Design: Engage a qualified professional engineer, as defined in Section 014000 "Quality Requirements," to design trapeze pipe hangers and equipment supports.

- B. Structural Performance: Hangers and supports for plumbing piping and equipment shall withstand the effects of gravity loads and stresses within limits and under conditions indicated according to ASCE/SEI 7.
 - 1. Design supports for multiple pipes, including pipe stands, capable of supporting combined weight of supported systems, system contents, and test water.

2.2 METAL PIPE HANGERS AND SUPPORTS

A. Carbon-Steel Pipe Hangers and Supports:

- 1. Description: MSS SP-58, Types 1 through 58, factory-fabricated components.
- 2. Galvanized Metallic Coatings: Pregalvanized, hot-dip galvanized, or electro-galvanized.
- 3. Nonmetallic Coatings: Plastic coated or epoxy powder coated.

B. Stainless Steel Pipe Hangers and Supports:

- 1. Description: MSS SP-58, Types 1 through 58, factory-fabricated components.

C. Copper Pipe and Tube Hangers:

- 1. Description: MSS SP-58, Types 1 through 58, copper-coated-steel, factory-fabricated components.

2.3 FASTENER SYSTEMS

A. Powder-Actuated Fasteners: Threaded-steel stud, for use in hardened portland cement concrete, with pull-out, tension, and shear capacities appropriate for supported loads and building materials where used.

B. Mechanical-Expansion Anchors: Insert-wedge-type anchors, for use in hardened portland cement concrete, with pull-out, tension, and shear capacities appropriate for supported loads and building materials where used.

- 1. Indoor Applications: stainless steel.
- 2. Outdoor Applications: Stainless steel.

2.4 PIPE-POSITIONING SYSTEMS

A. Description: IAPMO PS 42 positioning system composed of metal brackets, clips, and straps for positioning piping in pipe spaces; for plumbing fixtures in commercial applications.

2.5 MATERIALS

A. Aluminum: ASTM B221 (ASTM B221M).

B. Carbon Steel: ASTM A1011/A1011M.

C. Structural Steel: ASTM A36/A36M carbon-steel plates, shapes, and bars; black and galvanized.

- D. Stainless Steel: ASTM A240/A240M.
- E. Grout: ASTM C1107/C1107M, factory-mixed and -packaged, dry, hydraulic-cement, nonshrink and nonmetallic grout; suitable for interior and exterior applications.
 - 1. Properties: Nonstaining, noncorrosive, and nongaseous.
 - 2. Design Mix: 5000-psi (34.5-MPa), 28-day compressive strength.

PART 3 - EXECUTION

3.1 APPLICATION

- A. Strength of Support Assemblies: Where not indicated, select sizes of components, so strength will be adequate to carry present and future static loads within specified loading limits. Minimum static design load used for strength determination shall be weight of supported components plus 200 lb (90 kg).

3.2 INSTALLATION OF HANGERS AND SUPPORTS

- A. Metal Pipe-Hanger Installation: Comply with MSS SP-58. Install hangers, supports, clamps, and attachments as required to properly support piping from building structure.
- B. Fastener System Installation:
 - 1. Install powder-actuated fasteners for use in lightweight concrete or concrete slabs less than 4 inches (100 mm) thick in concrete, after concrete is placed and completely cured. Use operators that are licensed by powder-actuated tool manufacturer. Install fasteners according to powder-actuated tool manufacturer's operating manual.
 - 2. Install mechanical-expansion anchors in concrete, after concrete is placed and completely cured. Install fasteners according to manufacturer's written instructions.
- C. Install hangers and supports complete with necessary attachments, inserts, bolts, rods, nuts, washers, and other accessories.
- D. Install hangers and supports to allow controlled thermal and seismic movement of piping systems, to permit freedom of movement between pipe anchors, and to facilitate action of expansion joints, expansion loops, expansion bends, and similar units.
- E. Install lateral bracing with pipe hangers and supports to prevent swaying.
- F. Install building attachments within concrete slabs or attach to structural steel. Install additional attachments at concentrated loads, including valves, flanges, and strainers, NPS 2-1/2 (DN 65) and larger and at changes in direction of piping. Install concrete inserts before concrete is placed; fasten inserts to forms, and install reinforcing bars through openings at top of inserts.
- G. Load Distribution: Install hangers and supports, so that piping live and dead loads and stresses from movement will not be transmitted to connected equipment.

- H. Pipe Slopes: Install hangers and supports to provide indicated pipe slopes and to not exceed maximum pipe deflections allowed by ASME B31.9 for building services piping.

3.3 HANGER AND SUPPORT SCHEDULE

- A. Specific hanger and support requirements are in Sections specifying piping systems and equipment.
- B. Comply with MSS SP-58 for pipe-hanger selections and applications that are not specified in piping system Sections.
- C. Use hangers and supports with galvanized metallic coatings for piping and equipment that will not have field-applied finishes.
- D. Use nonmetallic coatings on attachments for electrolytic protection where attachments are in direct contact with copper tubing.
- E. Use stainless steel pipe hangers and stainless steel attachments for hostile environment applications.
- F. Use copper-plated pipe hangers and copper or stainless steel attachments for copper piping and tubing.
- G. Use padded hangers for piping that is subject to scratching.
- H. Horizontal-Piping Hangers and Supports: Unless otherwise indicated and except as specified in piping system Sections, install the following types:
 - 1. Adjustable, Steel Clevis Hangers (MSS Type 1): For suspension of noninsulated or insulated, stationary pipes NPS 1/2 to NPS 30 (DN 15 to DN 750).
 - 2. Yoke-Type Pipe Clamps (MSS Type 2): For suspension of up to 1050 deg F (566 deg C) pipes NPS 4 to NPS 24 (DN 100 to DN 600), requiring up to 4 inches (100 mm) of insulation.
 - 3. Carbon- or Alloy-Steel, Double-Bolt Pipe Clamps (MSS Type 3): For suspension of pipes NPS 3/4 to NPS 36 (DN 20 to DN 900), requiring clamp flexibility and up to 4 inches (100 mm) of insulation.
 - 4. Steel Pipe Clamps (MSS Type 4): For suspension of cold and hot pipes NPS 1/2 to NPS 24 (DN 15 to DN 600) if little or no insulation is required.
 - 5. Pipe Hangers (MSS Type 5): For suspension of pipes NPS 1/2 to NPS 4 (DN 15 to DN 100), to allow off-center closure for hanger installation before pipe erection.
 - 6. Adjustable, Swivel Split- or Solid-Ring Hangers (MSS Type 6): For suspension of noninsulated, stationary pipes NPS 3/4 to NPS 8 (DN 20 to DN 200).
 - 7. Adjustable, Steel Band Hangers (MSS Type 7): For suspension of noninsulated, stationary pipes NPS 1/2 to NPS 8 (DN 15 to DN 200).
 - 8. Adjustable Band Hangers (MSS Type 9): For suspension of noninsulated, stationary pipes NPS 1/2 to NPS 8 (DN 15 to DN 200).
 - 9. Adjustable, Swivel-Ring Band Hangers (MSS Type 10): For suspension of noninsulated, stationary pipes NPS 1/2 to NPS 8 (DN 15 to DN 200).
 - 10. Split Pipe Ring with or without Turnbuckle Hangers (MSS Type 11): For suspension of noninsulated, stationary pipes NPS 3/8 to NPS 8 (DN 10 to DN 200).

11. Extension Hinged or Two-Bolt Split Pipe Clamps (MSS Type 12): For suspension of noninsulated, stationary pipes NPS 3/8 to NPS 3 (DN 10 to DN 80).
 12. U-Bolts (MSS Type 24): For support of heavy pipes NPS 1/2 to NPS 30 (DN 15 to DN 750).
 13. Clips (MSS Type 26): For support of insulated pipes not subject to expansion or contraction.
 14. Pipe Saddle Supports (MSS Type 36): For support of pipes NPS 4 to NPS 36 (DN 100 to DN 900), with steel-pipe base stanchion support and cast-iron floor flange or carbon-steel plate.
 15. Pipe Stanchion Saddles (MSS Type 37): For support of pipes NPS 4 to NPS 36 (DN 100 to DN 900), with steel-pipe base stanchion support and cast-iron floor flange or carbon-steel plate, and with U-bolt to retain pipe.
 16. Adjustable Pipe Saddle Supports (MSS Type 38): For stanchion-type support for pipes NPS 2-1/2 to NPS 36 (DN 65 to DN 900) if vertical adjustment is required, with steel-pipe base stanchion support and cast-iron floor flange.
 17. Single-Pipe Rolls (MSS Type 41): For suspension of pipes NPS 1 to NPS 30 (DN 25 to DN 750), from two rods if longitudinal movement caused by expansion and contraction occurs.
 18. Adjustable Roller Hangers (MSS Type 43): For suspension of pipes NPS 2-1/2 to NPS 24 (DN 65 to DN 600), from single rod if horizontal movement caused by expansion and contraction occurs.
 19. Complete Pipe Rolls (MSS Type 44): For support of pipes NPS 2 to NPS 42 (DN 50 to DN 1050) if longitudinal movement caused by expansion and contraction occurs but vertical adjustment is unnecessary.
 20. Pipe Roll and Plate Units (MSS Type 45): For support of pipes NPS 2 to NPS 24 (DN 50 to DN 600) if small horizontal movement caused by expansion and contraction occurs and vertical adjustment is unnecessary.
 21. Adjustable Pipe Roll and Base Units (MSS Type 46): For support of pipes NPS 2 to NPS 30 (DN 50 to DN 750) if vertical and lateral adjustment during installation, in addition to expansion and contraction, is required.
- I. Vertical-Piping Clamps: Unless otherwise indicated and except as specified in piping system Sections, install the following types:
1. Extension Pipe or Riser Clamps (MSS Type 8): For support of pipe risers NPS 3/4 to NPS 24 (DN 24 to DN 600).
 2. Carbon- or Alloy-Steel Riser Clamps (MSS Type 42): For support of pipe risers NPS 3/4 to NPS 24 (DN 20 to DN 600) if longer ends are required for riser clamps.
- J. Hanger-Rod Attachments: Unless otherwise indicated and except as specified in piping system Sections, install the following types:
1. Steel Turnbuckles (MSS Type 13): For adjustment of up to 6 inches (150 mm) for heavy loads.
 2. Steel Clevises (MSS Type 14): For 120 to 450 deg F (49 to 232 deg C) piping installations.
 3. Swivel Turnbuckles (MSS Type 15): For use with MSS Type 11 split pipe rings.
 4. Malleable-Iron Sockets (MSS Type 16): For attaching hanger rods to various types of building attachments.
 5. Steel Weldless Eye Nuts (MSS Type 17): For 120 to 450 deg F (49 to 232 deg C) piping installations.

- K. Building Attachments: Unless otherwise indicated and except as specified in piping system Sections, install the following types:
1. Steel or Malleable-Concrete Inserts (MSS Type 18): For upper attachment to suspend pipe hangers from concrete ceiling.
 2. Top-Beam C-Clamps (MSS Type 19): For use under roof installations with bar-joint construction, to attach to top flange of structural shape.
 3. Side-Beam or Channel Clamps (MSS Type 20): For attaching to bottom flange of beams, channels, or angles.
 4. Center-Beam Clamps (MSS Type 21): For attaching to center of bottom flange of beams.
 5. Welded Beam Attachments (MSS Type 22): For attaching to bottom of beams if loads are considerable and rod sizes are large.
 6. C-Clamps (MSS Type 23): For structural shapes.
 7. Top-Beam Clamps (MSS Type 25): For top of beams if hanger rod is required tangent to flange edge.
 8. Side-Beam Clamps (MSS Type 27): For bottom of steel I-beams.
 9. Steel-Beam Clamps with Eye Nuts (MSS Type 28): For attaching to bottom of steel I-beams for heavy loads.
 10. Linked-Steel Clamps with Eye Nuts (MSS Type 29): For attaching to bottom of steel I-beams for heavy loads, with link extensions.
 11. Malleable-Beam Clamps with Extension Pieces (MSS Type 30): For attaching to structural steel.
 12. Welded-Steel Brackets: For support of pipes from below or for suspending from above by using clip and rod. Use one of the following for indicated loads:
 - a. Light (MSS Type 31): 750 lb (340 kg).
 - b. Medium (MSS Type 32): 1500 lb (680 kg).
 - c. Heavy (MSS Type 33): 3000 lb (1360 kg).
 13. Side-Beam Brackets (MSS Type 34): For sides of steel or wooden beams.
 14. Plate Lugs (MSS Type 57): For attaching to steel beams if flexibility at beam is required.
 15. Horizontal Travelers (MSS Type 58): For supporting piping systems subject to linear horizontal movement where headroom is limited.
- L. Saddles and Shields: Unless otherwise indicated and except as specified in piping system Sections, install the following types:
1. Steel-Pipe-Covering Protection Saddles (MSS Type 39): To fill interior voids with insulation that matches adjoining insulation.
 2. Protection Shields (MSS Type 40): Of length recommended in writing by manufacturer to prevent crushing insulation.
 3. Thermal Hanger-Shield Inserts: For supporting insulated pipe.
- M. Use mechanical-expansion anchors instead of building attachments where required in concrete construction.

END OF SECTION 220529

SECTION 221116 - DOMESTIC WATER PIPING

PART 1 - GENERAL

1.1 SUMMARY

- A. Section Includes:
 - 1. Copper tube and fittings - domestic water.
- B. Related Requirements:

1.2 ACTION SUBMITTALS

- A. Product data.

1.3 INFORMATIONAL SUBMITTALS

- A. Coordination Drawings: Piping layout, or BIM model, drawn to scale, showing the items described in this Section, and coordinated with all building trades.
- B. System purging and disinfecting activities report.
- C. Field quality-control reports.

1.4 QUALITY ASSURANCE

- A. Installer Qualifications: Installers of pressure-sealed joints are to be certified by pressure-seal joint manufacturer as having been trained and qualified to join piping with pressure-seal pipe couplings and fittings.

PART 2 - PRODUCTS

2.1 PERFORMANCE REQUIREMENTS

- A. Domestic water piping, tubing, fittings, joints, and appurtenances intended to convey or dispense water for human consumption are to comply with the U.S. Safe Drinking Water Act, with requirements of authorities having jurisdiction, and with NSF 61 and NSF 372, or be certified in compliance with NSF 61 and NSF 372 by an ANSI-accredited third-party certification body, in that the weighted average lead content at wetted surfaces is less than or equal to 0.25 percent.

2.2 PIPING MATERIALS

- A. Potable-water piping and components are to comply with NSF 14, NSF 61, and NSF 372. Include marking "NSF-pw" on piping.

2.3 COPPER TUBE AND FITTINGS - DOMESTIC WATER

- A. Drawn-Temper Copper Tube: ASTM B88, Type K (ASTM B88M, Type A).
- B. Annealed-Temper Copper Tube: ASTM B88, Type K (ASTM B88M, Type A).
- C. Cast-Copper, Solder-Joint Fittings: ASME B16.18, pressure fittings. Do not use solder joints on pipe sizes greater than NPS 4 (DN 100).
- D. Wrought-Copper, Solder-Joint Fittings: ASME B16.22, pressure fittings. Do not use solder joints on pipe sizes greater than NPS 4 (DN 100).
- E. Bronze Flanges: ASME B16.24, Class 150, with solder-joint ends. Do not use solder joints on pipe sizes greater than NPS 4 (DN 100).
- F. Cast Copper Unions: MSS SP-123, cast-copper-alloy, hexagonal-stock body, with ball-and-socket, metal-to-metal seating surfaces and solder-joint or threaded ends. Do not use solder joints on pipe sizes greater than NPS 4 (DN 100).
- G. Wrought Copper Unions: ASME B16.22. Do not use solder joints on pipe sizes greater than NPS 4 (DN 100).
- H. Pressure-Seal-Joint Fittings, Copper or Bronze - Domestic Water:
 - 1. <Double click here to find, evaluate, and insert list of manufacturers and products.>
 - 2. Housing: Copper.
 - 3. O-Rings and Pipe Stops: EPDM.
 - 4. Tools: Manufacturer's special tools.
 - 5. Minimum 200 psig (1370 kPa) working-pressure rating at 250 deg F (121 deg C).
- I. Copper-Tube, Push-on-Joint Fittings - Domestic Water:
 - 1. <Double click here to find, evaluate, and insert list of manufacturers and products.>
 - 2. Description:
 - a. Cast-copper fitting complying with ASME B16.18 or wrought-copper fitting complying with ASME B 16.22.
 - b. Stainless steel teeth and EPDM-rubber, O-ring seal in each end instead of solder-joint ends.

2.4 DUCTILE-IRON PIPE AND FITTINGS - DOMESTIC WATER

- A. Mechanical-Joint, Ductile-Iron Pipe:

1. AWWA C151/A21.51, with mechanical-joint bell and plain spigot end unless grooved or flanged ends are indicated.
 2. Glands, Gaskets, and Bolts: AWWA C111/A21.11, ductile- or gray-iron glands, rubber gaskets, and steel bolts.
- B. Standard-Pattern, Mechanical-Joint Fittings:
1. AWWA C110/A21.10, ductile or gray iron.
 2. Glands, Gaskets, and Bolts: AWWA C111/A21.11, ductile- or gray-iron glands, rubber gaskets, and steel bolts.
- C. Compact-Pattern, Mechanical-Joint Fittings:
1. AWWA C153/A21.53, ductile iron.
 2. Glands, Gaskets, and Bolts: AWWA C111/A21.11, ductile- or gray-iron glands, rubber gaskets, and steel bolts.
- D. Standard-Pattern, Push-on Joint Fittings:
1. AWWA C110/A21.10, ductile or gray iron.
 2. Gaskets: AWWA C111/A21.11, rubber.
- E. Compact-Pattern, Push-on Joint Fittings:
1. AWWA C153/A21.53, ductile iron.
 2. Gaskets: AWWA C111/A21.11, rubber.
- F. Plain-End, Ductile-Iron Pipe: AWWA C151/A21.51.
- G. Appurtenances for Grooved-End, Ductile-Iron Pipe - Domestic Water:
1. <Double click here to find, evaluate, and insert list of manufacturers and products.>
 2. Fittings for Grooved-End, Ductile-Iron Pipe: ASTM A47/A47M, malleable-iron castings or ASTM A536, ductile-iron castings with dimensions that match pipe.
 3. Mechanical Couplings for Grooved-End, Ductile-Iron-Piping:
 - a. AWWA C606 for ductile-iron-pipe dimensions.
 - b. Ferrous housing sections.
 - c. EPDM-rubber gaskets suitable for hot and cold water.
 - d. Bolts and nuts.
 - e. Minimum Pressure Rating:
 - 1) NPS 14 to NPS 18 (DN 350 to DN 450): 250 psig (1725 kPa).
 - 2) NPS 20 to NPS 46 (DN 500 to DN 900): 150 psig (1035 kPa).

PART 3 - EXECUTION

3.1 PIPING APPLICATIONS

- A. Under-building-slab, domestic water, building-service piping, NPS 3 (DN 80) and smaller is to be the following:
 - 1. Annealed-temper copper tube, ASTM B88, Type K (ASTM B88M, Type A); joints.
- B. Under-building-slab, domestic water, building-service piping, NPS 4 to NPS 8 (DN 100 to DN 200) and larger is to be the following:
 - 1. Annealed-temper copper tube, ASTM B88, Type K (ASTM B88M, Type A); wrought-copper, solder-joint fittings; and brazed joints.
- C. Under-building-slab, domestic water piping, NPS 2 (DN 50) and smaller is to be the following:
 - 1. Drawn-temper or annealed-temper copper tube, ASTM B88, Type L (ASTM B88M, Type B); wrought-copper, solder-joint fittings; and brazed joints.
- D. Aboveground domestic water piping, NPS 2 (DN 50) and smaller is to be the following:
 - 1. Drawn-temper copper tube, ASTM B88, Type L (ASTM B88M, Type B);copper, solder-joint fittings; and joints.
 - 2. Drawn-temper copper tube, ASTM B88, Type L (ASTM B88M, Type B); copper pressure-seal-joint fittings; and pressure-sealed joints.
 - 3. Drawn-temper copper tube, ASTM B88, Type L (ASTM B88M, Type B); copper push-on joint fittings; and push-on joints.
- E. Aboveground domestic water piping, NPS 2-1/2 to NPS 4 (DN 65 to DN 100) is to be the following:
 - 1. Drawn-temper copper tube, ASTM B88, Type L (ASTM B88M, Type B);copper, solder-joint fittings; and joints.
 - 2. Drawn-temper copper tube, ASTM B88, Type L (ASTM B88M, Type B); copper pressure-seal-joint fittings; and pressure-sealed joints.

3.2 EARTHWORK

- A. Comply with requirements in Section 312000 "Earth Moving" for excavating, trenching, and backfilling.

3.3 INSTALLATION OF PIPING

- A. Drawing plans, schematics, and diagrams indicate general location and arrangement of domestic water piping. Indicated locations and arrangements are used to size pipe and calculate friction loss, expansion, and other design considerations. Install piping as indicated unless deviations to layout are approved on coordination drawings.
- B. Install copper tubing under building slab in accordance with CDA's "Copper Tube Handbook."

- C. Install underground copper tube in PE encasement in accordance with ASTM A674 or AWWA C105/A21.5.
- D. Install valves at the connection of every fixture. Valve shall be approved for drinking water and be same size a pipe.
- E. Install domestic water piping level with 0.25 percent slope downward toward drain without pitch and plumb.
- F. Install piping concealed from view and protected from physical contact by building occupants unless otherwise indicated and except in equipment rooms and service areas.
- G. Install piping indicated to be exposed and piping in equipment rooms and service areas at right angles or parallel to building walls. Diagonal runs are prohibited unless specifically indicated otherwise.
- H. Install piping above accessible ceilings to allow sufficient space for ceiling panel removal, and coordinate with other services occupying that space.
- I. Install piping to permit valve servicing.
- J. Install nipples, unions, special fittings, and valves with pressure ratings the same as or higher than the system pressure rating used in applications below unless otherwise indicated.
- K. Install piping free of sags and bends.
- L. Install fittings for changes in direction and branch connections.
- M. Install unions in copper tubing at final connection to each piece of equipment, machine, and specialty.
- N. Install sleeves for piping penetrations of walls, ceilings, and floors. Comply with requirements for sleeves specified in Section 220500 "Common Work Results for Plumbing."
- O. Install sleeve seals for piping penetrations of concrete walls and slabs. Comply with requirements for sleeve seals specified in Section 220500 "Common Work Results for Plumbing."
- P. Install escutcheons for piping penetrations of walls, ceilings, and floors. Comply with requirements for escutcheons specified in Section 220500 "Common Work Results for Plumbing."

3.4 JOINT CONSTRUCTION

- A. Ream ends of pipes and tubes and remove burrs. Bevel plain ends of steel pipe.
- B. Remove scale, slag, dirt, and debris from inside and outside of pipes, tubes, and fittings before assembly.

- C. Threaded Joints: Thread pipe with tapered pipe threads in accordance with ASME B1.20.1. Cut threads full and clean using sharp dies. Ream threaded pipe ends to remove burrs and restore full ID. Join pipe fittings and valves as follows:
 - 1. Apply appropriate tape or thread compound to external pipe threads.
 - 2. Damaged Threads: Do not use pipe or pipe fittings with threads that are corroded or damaged.
- D. Brazed Joints for Copper Tubing: Comply with CDA's "Copper Tube Handbook," "Braze Joints" chapter.
- E. Soldered Joints for Copper Tubing: Apply ASTM B813, water-flushable flux to end of tube. Join copper tube and fittings in accordance with ASTM B828 or CDA's "Copper Tube Handbook."
- F. Pressure-Sealed Joints for Copper Tubing: Join copper tube and pressure-seal fittings with tools and procedure recommended by pressure-seal-fitting manufacturer. Leave insertion marks on pipe after assembly.
- G. Push-on Joints for Copper Tubing: Clean end of tube. Measure insertion depth with manufacturer's depth gage. Join copper tube and push-on joint fittings by inserting tube to measured depth.
- H. Extruded-Tee Connections: Form tee in copper tube in accordance with ASTM F2014. Use tool designed for copper tube; drill pilot hole, form collar for outlet, dimple tube to form seating stop, and braze branch tube into collar.
- I. Joint Construction for Grooved-End Copper Tubing: Make joints in accordance with AWWA C606. Roll groove ends of tubes. Lubricate and install gasket over ends of tubes or tube and fitting. Install coupling housing sections over gasket with keys seated in tubing grooves. Install and tighten housing bolts.

3.5 INSTALLATION OF HANGERS AND SUPPORTS

- A. Comply with requirements for seismic-restraint devices.
- B. Comply with requirements for hangers, supports, and anchor devices in Section 220529 "Hangers and Supports for Plumbing Piping and Equipment."
- C. Install hangers for copper, with maximum horizontal spacing and minimum rod diameters, to comply with MSS SP-58, locally enforced codes, and authorities having jurisdiction requirements, whichever are most stringent.
- D. Support horizontal piping within 12 inches (300 mm) of each fitting.
- E. Support vertical runs of copper to comply with MSS SP-58, locally enforced codes, and authorities having jurisdiction requirements, whichever are most stringent.

3.6 PIPING CONNECTIONS

- A. Drawings indicate general arrangement of piping, fittings, and specialties.
- B. When installing piping adjacent to equipment and machines, allow space for service and maintenance.
- C. Connect domestic water piping to exterior water-service piping. Use transition fitting to join dissimilar piping materials.
- D. Connect domestic water piping to water-service piping with shutoff valve; extend and connect to the following:
 - 1. Domestic Water Booster Pumps: Cold-water suction and discharge piping.
 - 2. Water Heaters: Cold-water inlet and hot-water outlet piping in sizes indicated, but not smaller than sizes of water heater connections.
 - 3. Plumbing Fixtures: Cold- and hot-water-supply piping in sizes indicated, but not smaller than that required by plumbing code.
 - 4. Equipment: Cold- and hot-water-supply piping as indicated, but not smaller than equipment connections. Provide shutoff valve and union for each connection. Use flanges instead of unions for NPS 2-1/2 (DN 65) and larger.

3.7 CLEANING

- A. Clean and disinfect potable domestic water piping as follows:
 - 1. Purge new piping and parts of existing piping that have been altered, extended, or repaired before using.
 - 2. Use purging and disinfecting procedures prescribed by authorities having jurisdiction; if methods are not prescribed, use procedures described in either AWWA C651 or AWWA C652 or follow procedures described below:
 - a. Flush piping system with clean, potable water until dirty water does not appear at outlets.
 - b. Fill and isolate system in accordance with either of the following:
 - 1) Fill system or part thereof with water/chlorine solution with at least 50 ppm (50 mg/L) of chlorine. Isolate with valves and allow to stand for 24 hours.
 - 2) Fill system or part thereof with water/chlorine solution with at least 200 ppm (200 mg/L) of chlorine. Isolate and allow to stand for three hours.
 - c. Flush system with clean, potable water until no chlorine is in water coming from system after the standing time.
 - d. Repeat procedures if biological examination shows contamination.
 - e. Submit water samples in sterile bottles to authorities having jurisdiction.
- B. Clean non-potable domestic water piping as follows:
 - 1. Purge new piping and parts of existing piping that have been altered, extended, or repaired before using.

2. Use purging procedures prescribed by authorities having jurisdiction or; if methods are not prescribed, follow procedures described below:
 - a. Flush piping system with clean, potable water until dirty water does not appear at outlets.
 - b. Submit water samples in sterile bottles to authorities having jurisdiction. Repeat procedures if biological examination shows contamination.
 - C. Prepare and submit reports of purging and disinfecting activities. Include copies of water-sample approvals from authorities having jurisdiction.
 - D. Clean interior of domestic water piping system. Remove dirt and debris as work progresses.
- 3.8 ADJUSTING
- A. Perform the following adjustments before operation:
 1. Close drain valves, hydrants, and hose bibbs.
 2. Open shutoff valves to fully open position.
- 3.9 FIELD QUALITY CONTROL
- A. Tests and Inspections:
 1. Piping Inspections:
 - a. Do not enclose, cover, or put piping into operation until it has been inspected and approved by authorities having jurisdiction.
 - b. During installation, notify authorities having jurisdiction at least one day before inspection must be made. Perform tests specified below in presence of authorities having jurisdiction:
 - 1) Roughing-in Inspection: Arrange for inspection of piping before concealing or closing in after installation and before setting fixtures.
 - 2) Final Inspection: Arrange for authorities having jurisdiction to observe tests specified in "Piping Tests" Subparagraph and to ensure compliance with requirements.
 - c. Reinspection: If authorities having jurisdiction find that piping will not pass tests or inspections, make required corrections and arrange for reinspection.
 - d. Reports: Prepare inspection reports and have them signed by authorities having jurisdiction.
 2. Piping Tests:
 - a. Fill domestic water piping. Check components to determine that they are not air bound and that piping is full of water.
 - b. Test for leaks and defects in new piping and parts of existing piping that have been altered, extended, or repaired. If testing is performed in segments, submit a separate report for each test, complete with diagram of portion of piping tested.

- c. Leave new, altered, extended, or replaced domestic water piping uncovered and unconcealed until it has been tested and approved. Expose work that was covered or concealed before it was tested.
 - d. Cap and subject piping to static water pressure of 50 psig (345 kPa) above operating pressure, without exceeding pressure rating of piping system materials. Isolate test source and allow it to stand for four hours. Leaks and loss in test pressure constitute defects that must be repaired.
 - e. Hydrostatic testing and documentation of test results for polypropylene (PP-R and PP-RCT) pipe to be in accordance with manufacturer's written instructions and submitted to manufacturer upon successful completion per warranty requirements.
 - f. Repair leaks and defects with new materials, and retest piping or portion thereof until satisfactory results are obtained.
 - g. Prepare reports for tests and for corrective action required.
- B. Domestic water piping will be considered defective if it does not pass tests and inspections.
- C. Prepare test and inspection reports.

END OF SECTION 221116

SECTION 221414 - STORM DRAINAGE PIPING

PART 1 - GENERAL

1.1 SUMMARY

- A. Section Includes:
 - 1. PVC pipe and fittings.
 - 2. Specialty pipe fittings.

1.2 ACTION SUBMITTALS

- A. Product Data:
 - 1. PVC pipe and fittings.
 - 2. Specialty pipe fittings.

1.3 INFORMATIONAL SUBMITTALS

- A. Coordination Drawings: Plans and elevations, or Building Information Model (BIM) drawn to scale, showing items described in this Section and coordinated with all building trades.
- B. Seismic Qualification Certificates: For storm drainage piping, accessories, and components, from manufacturer.
- C. Field Quality-Control Reports: Inspection reports signed by authorities having jurisdiction.

1.4 QUALITY ASSURANCE

- A. Provide materials bearing label, stamp, or other markings of specified testing agency.

1.5 WARRANTY

- A. Listed manufacturers to provide labeling and warranty of their respective products

PART 2 - PRODUCTS

2.1 PERFORMANCE REQUIREMENTS

- A. Components and installation are to be capable of withstanding the following minimum working pressure unless otherwise indicated:
 - 1. Storm Drainage Piping: 10-foot head of water (30 kPa).

2.2 PIPING MATERIALS

- A. Piping materials to bear label, stamp, or other markings of specified testing agency.
- B. Comply with requirements in "Piping Schedule" Article for applications of pipe, tube, fitting materials, and joining methods for specific services, service locations, and pipe sizes.

2.3 PVC PIPE AND FITTINGS

- A. PVC Pipe:
 - 1. NSF Marking: Comply with NSF 14 for plastic piping components. Include marking with "NSF-dwv" for plastic storm drain and "NSF-sewer" for plastic storm sewer piping.
 - 2. Solid-Wall PVC Pipe: ASTM D2665 drain, waste, and vent.
- B. PVC Socket Fittings:
 - 1. Standard: ASTM D2665, made in accordance with ASTM D3311, drain, waste, and vent patterns and to fit Schedule 40 pipe.
 - 2. NSF Marking: Comply with NSF 14 for plastic piping components. Include marking with "NSF-dwv" for plastic storm drain and "NSF-sewer" for plastic storm sewer piping.
- C. Adhesive Primer: ASTM F656.
- D. Solvent Cement: ASTM D2564.

PART 3 - EXECUTION

3.1 EARTH MOVING

- A. Comply with requirements for excavating, trenching, and backfilling specified in Section 312000 "Earth Moving."

3.2 INSTALLATION OF PIPING

- A. Drawing plans, schematics, and diagrams indicate general location and arrangement of piping systems.
- B. Install piping as indicated unless deviations from layout are approved on coordination drawings.
- C. Install piping in concealed locations.
 - 1. Piping installed in equipment rooms, service areas, and where indicated may be exposed.
- D. Install piping indicated to be exposed and piping in equipment rooms and service areas at right angles or parallel to building walls. Diagonal runs are prohibited unless specifically indicated.
- E. Install piping above accessible ceilings to allow sufficient space for ceiling panel removal.
- F. Install piping to permit valve servicing.

- G. Install piping at indicated slopes.
- H. Install piping free of sags and bends.
- I. Install fittings for changes in direction and branch connections.
- J. Install piping to allow application of insulation.
- K. Make changes in direction for piping using appropriate branches, bends, and long-sweep bends.
 - 1. Do not change direction of flow more than 90 degrees.
 - 2. Use proper size of standard increasers and reducers if pipes of different sizes are connected.
 - a. Reducing size of drainage piping in direction of flow is prohibited.
- L. Lay buried building piping beginning at low point of each system.
 - 1. Install true to grades and alignment indicated, with unbroken continuity of invert. Place hub ends of piping upstream.
 - 2. Install required gaskets according to manufacturer's written instructions for use of lubricants, cements, and other installation requirements.
 - 3. Maintain swab in piping and pull past each joint as completed.
- M. Install piping at the following minimum slopes unless otherwise indicated.
 - 1. Building Storm Drain: 1/4 inch per foot (2 percent) downward in direction of flow for piping NPS 3 (DN 80) and smaller; downward in direction of flow for piping NPS 4 (DN 100) and larger.
 - 2. Horizontal Storm Drainage Piping: 1/4 inch per foot (2 percent) downward in direction of flow.
- N. Install aboveground PVC piping in accordance with ASTM D2665.
- O. Install underground PVC piping in accordance with ASTM D2321.
- P. Plumbing Specialties:
 - 1. Install cleanouts in storm drainage gravity-flow piping in accessible locations.
 - a. Install cleanout fitting with closure plug inside the building in storm drainage force-main piping.
- Q. Do not enclose, cover, or put piping into operation until it is inspected and approved by authorities having jurisdiction.
- R. Install sleeves for piping penetrations of walls, ceilings, and floors.
 - 1. Comply with requirements for sleeves specified in Section 220500 "Common Work Results for Plumbing."
- S. Install sleeve seals for piping penetrations of concrete walls and slabs.

1. Comply with requirements for sleeve seals specified in Section 220500 "Common Work Results for Plumbing."
- T. Install escutcheons for piping penetrations of walls, ceilings, and floors.
1. Comply with requirements for escutcheons specified in Section 220500 "Common Work Results for Plumbing."

3.3 JOINT CONSTRUCTION

- A. Plastic, Nonpressure-Piping, Solvent-Cemented Joints: Clean and dry joining surfaces. Join pipe and fittings in accordance with the following:
1. Comply with ASTM F402 for safe-handling practice of cleaners, primers, and solvent cements.
 2. PVC Piping: Join in accordance with ASTM D2855 and ASTM D2665 appendices.
- B. Joint Restraints and Sway Bracing:
1. Provide joint restraints and sway bracing for storm drainage piping joints to comply with the following conditions:
 - a. Provide axial restraint for pipe and fittings 5 inches (125 mm) and larger, upstream and downstream of all changes in direction, branches, and changes in diameter greater than two pipe sizes.
 - b. Provide rigid sway bracing for pipe and fittings 4 inches (100 mm) and larger, upstream and downstream of all changes in direction 45 degrees and greater.
 - c. Provide rigid sway bracing for pipe and fittings 5 inches (125 mm) and larger, upstream and downstream of all changes in direction and branch openings.

3.4 INSTALLATION OF HANGERS AND SUPPORTS

- A. Comply with requirements for hangers, supports, and anchor devices specified in Section 220529 "Hangers and Supports for Plumbing Piping and Equipment."
1. Install carbon-steel pipe hangers for horizontal piping in noncorrosive environments.
 2. Install stainless steel pipe hangers for horizontal piping in corrosive environments.
 3. Install carbon-steel pipe support clamps for vertical piping in noncorrosive environments.
 4. Install stainless steel pipe support clamps for vertical piping in corrosive environments.
 5. Vertical Piping: MSS Type 8 or Type 42, clamps.
 6. Install individual, straight, horizontal piping runs:
 - a. 100 Feet (30 m) and Less: MSS Type 1, adjustable, steel clevis hangers.
 - b. Longer Than 100 Feet (30 m): MSS Type 43, adjustable roller hangers.
 - c. Longer Than 100 Feet (30 m) if Indicated: MSS Type 49, spring cushion rolls.
 7. Multiple, Straight, Horizontal Piping Runs 100 Feet (30 m) or Longer: MSS Type 44, pipe rolls. Support pipe rolls on trapeze.

- B. Install hangers for PVC piping, with maximum horizontal spacing and minimum rod diameters, to comply with manufacturer's written instructions, locally enforced codes, and authorities having jurisdiction requirements, whichever are most stringent.
- C. Support horizontal piping and tubing within 12 inches (300 mm) of each fitting and coupling.
- D. Support vertical PVC piping with manufacturer's written instructions, locally enforced codes, and authorities having jurisdiction requirements, whichever are most stringent.

3.5 CONNECTIONS

- A. Drawings indicate general arrangement of piping, fittings, and specialties.
- B. Connect interior storm drainage piping to exterior storm drainage piping. Use transition fitting to join dissimilar piping materials.
- C. Connect storm drainage piping to roof drains and storm drainage specialties.
 - 1. Install test tees (wall cleanouts) in conductors near floor, and floor cleanouts with cover flush with floor.
 - 2. Install horizontal backwater valves with cleanout cover flush with floor.
- D. Where installing piping adjacent to equipment, allow space for service and maintenance of equipment.
- E. Make connections in accordance with the following unless otherwise indicated:
 - 1. Install unions, in piping NPS 2 (DN 50) and smaller, adjacent to each valve and at final connection to each piece of equipment.
 - 2. Install flanges, in piping NPS 2-1/2 (DN 65) and larger, adjacent to flanged valves and at final connection to each piece of equipment.

3.6 IDENTIFICATION

- A. Identify exposed storm drainage piping.
- B. Comply with requirements for identification specified in Section 220553 "Identification for Plumbing Piping and Equipment."

3.7 FIELD QUALITY CONTROL

- A. During installation, notify authorities having jurisdiction at least 24 hours before inspection must be made. Perform tests specified below in presence of authorities having jurisdiction.
 - 1. Roughing-in Inspection: Arrange for inspection of piping before concealing or closing-in after roughing-in.
 - 2. Final Inspection: Arrange for final inspection by authorities having jurisdiction to observe tests specified below and to ensure compliance with requirements.

- B. Reinspection: If authorities having jurisdiction find that piping will not pass test or inspection, make required corrections and arrange for reinspection.
- C. Reports: Prepare inspection reports and have them signed by authorities having jurisdiction.
- D. Test storm drainage piping in accordance with procedures of authorities having jurisdiction or, in absence of published procedures, as follows:
 - 1. Test for leaks and defects in new piping and parts of existing piping that have been altered, extended, or repaired.
 - a. If testing is performed in segments, submit separate report for each test, complete with diagram of portion of piping tested.
 - 2. Leave uncovered and unconcealed new, altered, extended, or replaced storm drainage piping until it has been tested and approved.
 - a. Expose work that was covered or concealed before it was tested.
 - 3. Test Procedure:
 - a. Test storm drainage piping on completion of roughing-in.
 - b. Close openings in piping system and fill with water to point of overflow, but not less than 10-foot head of water (30 kPa).
 - c. From 15 minutes before inspection starts until completion of inspection, water level must not drop.
 - d. Inspect joints for leaks.
 - 4. Repair leaks and defects with new materials and retest piping, or portion thereof, until satisfactory results are obtained.
 - 5. Prepare reports for tests and required corrective action.

3.8 CLEANING

- A. Clean interior of piping. Remove dirt and debris as work progresses.

3.9 PROTECTION

- A. Protect piping and drains during remainder of construction period to avoid clogging with dirt and debris and to prevent damage from traffic and construction work.
- B. Place plugs in ends of uncompleted piping at end of day and when work stops.
- C. Repair damage to adjacent materials caused by storm drainage piping installation.

3.10 PIPING SCHEDULE

- A. Flanges and unions may be used on aboveground pressure piping unless otherwise indicated.

- B. Aboveground storm drainage piping NPS 6 (DN 150) and smaller is to be the following:
 - 1. Solid-wall PVC pipe, PVC socket fittings, and solvent-cemented joints.

- C. Aboveground, storm drainage piping NPS 8 (DN 200) and larger Insert pipe size range is to be any of the following:
 - 1. Solid-wall PVC pipe, PVC socket fittings, and solvent-cemented joints.

- D. Underground storm drainage piping NPS 6 (DN 150) and smaller is to be the following:
 - 1. Solid-wall PVC pipe, PVC socket fittings, and solvent-cemented joints.

- E. Underground, storm drainage piping NPS 8 (DN 200) and larger is to be the following:
 - 1. Solid-wall PVC pipe, PVC socket fittings, and solvent-cemented joints.

END OF SECTION 221414

SECTION 221423 – STORM DRAINAGE PIPING SPECIALTIES

PART 1 - GENERAL

1.1 SUMMARY

A. Section Includes:

1. General-purpose roof drains.
2. Cleanouts.

B. Related Requirements:

1.2 ACTION SUBMITTALS

A. Product Data:

1. General-purpose roof drains.
2. Cleanouts.

1.3 QUALITY ASSURANCE

- A. Provide drainage piping specialties are to bear label, stamp, or other markings of specified testing agency.

PART 2 - PRODUCTS

2.1 GENERAL-PURPOSE ROOF DRAINS

A. Cast-Iron Roof Drains.

1. Cast-Iron, Large-Sump, General-Purpose Roof Drains: .
 - a. Standard: ASME A112.6.4.
 - b. Body Material: Cast iron.
 - c. Dimension of Body: Nominal 14-to 16-inch (357- to 406-mm) diameter.
 - d. Dome Material: Aluminum.
 - e. Combination flashing ring and gravel stop.
 - f. Outlet: Bottom.
 - g. Outlet Type: No-hub.
 - 1) Vandal-proof dome.
2. Cast-Iron, Medium-Sump, General-Purpose Roof Drains: .
 - a. Standard: ASME A112.6.4.
 - b. Body Material: Cast iron.
 - c. Dimension of Body: 8- to 12-inch (203- to 305-mm) diameter.
 - d. Dome Material: Aluminum.

- e. Combination flashing ring and gravel stop.
 - f. Outlet: Bottom.
 - g. Outlet Type: No-hub.
 - h. Options:
 - 1) Vandal-proof dome.
3. Cast-Iron, Small-Sump, General-Purpose Roof Drains: Insert drawing designation if any.
- a. Standard: ASME A112.6.4.
 - b. Body Material: Cast iron.
 - c. Dimension of Body: Nominal 8-inch (203-mm) diameter.
 - d. Dome Material: Cast iron.
 - e. Combination flashing ring and gravel stop.
 - f. Outlet: Bottom.
 - g. Outlet Type: No-hub.
 - h. Options:
 - 1) Vandal-proof dome.
4. Cast-Iron Cornice and Gutter Roof Drains: .
- a. Standard: ASME A112.6.4.
 - b. Body Material: Cast iron
 - c. Dimension of Body: Nominal 6-inch (152-mm) diameter.
 - d. Dome Material: Bronze.
 - e. Outlet: Bottom.
 - f. Outlet Type: Threaded.
 - g. Options:
 - 1) Vandal-Proof Dome.
5. Cast-Iron Parapet Roof Drains: .
- a. Standard: ASME A112.6.4.
 - b. Body Material: Cast iron.
 - c. Grate Material: Bronze.
 - d. Outlet: Back.
 - e. Outlet Type: Threaded.
 - f. Options:
 - 1) Vandal-proof grate.

2.2 MISCELLANEOUS STORM DRAINAGE PIPING SPECIALTIES

- A. Downspout Adapters: <Insert drawing designation if any>.
- 1. Description: Manufactured, gray-iron casting, for attaching to horizontal-outlet, parapet roof drain and to exterior sheet metal downspout.
 - 2. Size: Inlet size to match parapet drain outlet.
- B. Downspout Boots:
- 1. Description: Manufactured, ASTM A48/A48M, gray-iron casting, with strap or ears for attaching to building; NPS 4 (DN 100) outlet; and shop-applied bituminous coating.
 - 2. Size: Inlet size to match downspout and NPS 4 (DN 100) outlet.
- C. Metal Downspout Nozzles:

1. Description: Nozzle with wall flange and mounting holes to cover rough opening and serve as anchor.
2. Size: Same as connected downspout.
3. Material: Cast bronze or nickel bronze nozzle and flange.
4. Piping Connection Type: Threaded.
5. Opening Protection: Birdscreen.

D. Metal Downspout Nozzles with PVC Insert:

1. Description: Nozzle with wall flange and mounting holes to cover rough opening and serve as anchor.
2. Size: Same as connected downspout.
3. Material: Cast nickel brass, with integral PVC insert.
4. Piping Connection Type: Solvent welded.
5. Finish: Nickel brass.
6. Opening Protection: Birdscreen.

2.3 CLEANOUTS

A. Cast-Iron Cleanouts.

1. Cast-Iron Exposed Cleanouts:
 - a. Standard: ASME A112.36.2M.
 - b. Size: Same as connected branch.
 - c. Body Material: Hub-and-spigot, cast-iron soil pipe T-branch as required to match connected piping.
 - d. Closure: Countersunk, plug.
 - e. Closure Plug Size: Same as, or not more than, one size smaller than cleanout size.
2. Cast-Iron Exposed Floor Cleanouts:
 - a. Standard: ASME A112.36.2M.
 - b. Size: Same as connected branch.
 - c. Type: Adjustable housing.
 - d. Body or Ferrule: Cast iron.
 - e. Outlet Connection: No-hub.
 - f. Closure: Brass plug with straight threads and gasket.
 - g. Adjustable Housing Material: Cast iron.
 - h. Frame and Cover Material and Finish: Nickel-bronze, copper alloy.
 - i. Frame and Cover Shape: Round.
 - j. Top Loading Classification: Extra-Heavy Duty.
 - k. Riser: ASTM A74, Extra-Heavy Class, cast-iron drainage pipe fitting and riser to cleanout.
 - l. Options:
 - 1) Clamping device.
3. Cast-Iron Wall Cleanouts:
 - a. Standard: ASME A112.36.2M. Include wall access.
 - b. Size: Same as connected drainage piping.
 - c. Body: Hub-and-spigot, cast-iron soil pipe T-branch as required to match connected piping.

- d. Closure Plug:
 - 1) Material: Brass.
 - 2) Head: Countersunk.
 - 3) Drilled and threaded for cover attachment screw.
 - 4) Size: Same as, or not more than, one size smaller than cleanout size.
- e. Wall-Access Cover Plate: Round, cover plate with screw.
- f. Wall-Access Frame and Cover: Round, wall-installation frame and cover.

PART 3 - EXECUTION

3.1 INSTALLATION

- A. Install roof drains in accordance with roof membrane manufacturer's written installation instructions at low points of roof areas.
 - 1. Install flashing collar or flange of roof drain to maintain integrity of waterproof membranes where penetrated.
 - 2. Install expansion joints, if indicated, in roof drain outlets.
 - 3. Position roof drains for easy access and maintenance.
- B. Install downspout adapters on outlet of back-outlet parapet roof drains and connect to sheet metal downspouts.
- C. Install downspout boots at grade with top 6 inches (152 mm) above grade. Secure to building wall.
- D. Install downspout nozzles at exposed bottom of conductors where they spill onto grade.
- E. Install cleanouts in aboveground piping and building drain piping in accordance with the following instructions unless otherwise indicated:
 - 1. Use cleanouts the same size as drainage piping up to NPS 4 (DN 100). Use NPS 4 (DN 100) for larger drainage piping unless larger cleanout is indicated.
 - 2. Locate cleanouts at each change in direction of piping greater than 45 degrees.
 - 3. Locate cleanouts at minimum intervals of 50 ft. (15 m) for piping NPS 4 (DN 100) and smaller and 100 ft. (30 m) for larger piping.
 - 4. Locate cleanouts at base of each vertical storm piping conductor.
- F. For floor cleanouts for piping below floors, install cleanout deck plates with top flush with finished floor.
- G. For cleanouts located in concealed piping, install cleanout wall access covers, of types indicated, with frame and cover flush with finished wall.
- H. Install test tees in vertical conductors and near floor.
- I. Install wall cleanouts in vertical conductors. Install access door in wall if indicated.

- J. Install through-penetration firestop assemblies for penetrations of fire- and smoke-rated assemblies.

3.2 CONNECTIONS

- A. for piping specified in Section 221414 "Storm Drainage Piping." Drawings indicate general arrangement of piping, fittings, and specialties.

3.3 INSTALLATION OF FLASHING

- A. Fabricate flashing from single piece of metal unless large pans, sumps, or other drainage shapes are required.
- B. Install sheet flashing on pipes, sleeves, and specialties passing through or embedded in floors and roofs with waterproof membrane.
- C. Set flashing on floors and roofs in solid coating of bituminous cement.
- D. Secure flashing into sleeve and specialty clamping ring or device.

3.4 CLEANING

- A. Clean piping specialties during installation and remove dirt and debris as work progresses.

3.5 PROTECTION

- A. Protect piping specialties during remainder of construction period to avoid clogging with dirt or debris and to prevent damage from traffic and construction work.
- B. Place plugs in ends of uncompleted piping at end of each day and when work stops.

END OF SECTION 221423

SECTION 233416 - CENTRIFUGAL HVAC FANS

PART 1 - GENERAL

1.1 SUMMARY

A. Section Includes:

1. Backward-inclined centrifugal fans, including airfoil and curved blade fans.
2. Forward-curved centrifugal fans.

1.2 ACTION SUBMITTALS

A. Product Data: For each type of product.

B. Shop Drawings:

1. Include plans, elevations, sections, and attachment details.
2. Include details of equipment assemblies. Indicate dimensions, weights, loads, required clearances, method of field assembly, components, and location and size of each field connection.
3. Include diagrams for power, signal, and control wiring.
4. Design Calculations: Calculate requirements for selecting vibration isolators and seismic restraints and for designing vibration isolation bases.
5. Vibration Isolation Base Details: Detail fabrication, including anchorages and attachments to structure and to supported equipment. Include adjustable motor bases, rails, and frames for equipment mounting.

C. Delegated Design Submittal: For vibration isolation, supports, and seismic restraints indicated to comply with performance requirements and design criteria, including analysis data signed and sealed by the qualified professional engineer responsible for their preparation.

1. Design Calculations: Calculate requirements for selecting vibration isolators, supports, , seismic restraints, and for designing vibration isolation bases.

1.3 INFORMATIONAL SUBMITTALS

A. Coordination Drawings: Fan room layout and relationships between components and adjacent structural and mechanical elements, drawn to scale, and coordinated with each other, using input from installers of the items involved.

B. Seismic Qualification Data: For fans, accessories, and components, from manufacturer.

C. Field quality-control reports.

1.4 CLOSEOUT SUBMITTALS

- A. Operation and maintenance data.

PART 2 - PRODUCTS

2.1 PERFORMANCE REQUIREMENTS

- A. Unusual Service Conditions
 - 1. Base fan-performance ratings on the following:
 - a. Ambient Temperature: 90 deg F.
 - b. Altitude: 80 feet above sea level.
- B. Electrical Components, Devices, and Accessories: Listed and labeled as defined in NFPA 70, by a qualified testing agency, and marked for intended location and application.
- C. NFPA Compliance: Comply with NFPA 90A for design, fabrication, and installation of unit components.
- D. ASHRAE 62.1 Compliance: Applicable requirements in ASHRAE 62.1, Section 5 - "Systems and Equipment" and Section 7 - "Construction and Startup."
- E. ASHRAE/IES 90.1 Compliance: Applicable requirements in ASHRAE/IES 90.1, Section 6 - "Heating, Ventilating, and Air-Conditioning."
- F. Delegated Design: Engage a qualified professional engineer, as defined in Section 014000 "Quality Requirements," to design vibration isolation, supports and seismic restraints, including comprehensive engineering analysis by a qualified professional engineer, using performance and design criteria indicated.
- G. Seismic Performance: Centrifugal fans shall withstand the effects of earthquake motions determined according to ASCE/SEI 7.
 - 1. The term "withstand" means "the unit will remain in place without separation of any parts when subjected to the seismic forces specified and the unit will be fully operational after the seismic event."
- H. Capacities and Characteristics:
 - 1. Fan Type: Centrifugal roof mounted.
 - 2. Blade Type: Forward curved.
 - 3. Airflow:
 - a. For buildings of 11,500 ft² floor area shall be 1,725 cfm
 - b. For Buildings of 23,000 ft² floor area shall be 3,450 cfm
 - c. For buildings of different areas, the fan shall be sized at 0.15 cfm/ft²
 - 4. Total Static Pressure: 0.50 **inches wg.**
 - 5. Class: AMCA 99, Section 14, Class I.
 - 6. Drive Type: Direct.

7. Discharge Arrangement: Down blast.
8. Housing Material: Aluminum.
9. Housing Coating: None;
10. Wheel Material: Aluminum.
11. Fan shall be Miami Dade approved for hurricane winds.
12. Fan shall be provided with hurricane tie downs from the manufacturer.
13. Brake Horsepower:
 - a. For 1,750 cfm fan 0.20 BHP
 - b. For 3,450 cfm fan 0.40 BHP
 - c. BHP shall be coordinated with electrical and equipment manufacturers.
14. Motor:
 - a. Motor Enclosure Type: Totally enclosed, fan cooled.
 - b. Service Factor: 100 percent.
 - c. Suitable for Use with Variable-Frequency Drive: Yes.
 - d. Electrical Characteristics:
 - 1) To be coordinated with existing electrical conditions.

PART 3 - EXECUTION

3.1 INSTALLATION, GENERAL

- A. Install centrifugal fans level and plumb.
- B. Disassemble and reassemble units, as required for moving to the final location, according to manufacturer's written instructions.
- C. Lift and support units with manufacturer's designated lifting or supporting points.
- D. Equipment Mounting:
- E. Curb Support, Field Built-Up: Install roof curb on roof structure, level and secure, according to "The NRCA Roofing and Waterproofing Manual," detail "Equipment Support Curb," number "SPF-9" (page 1409) and detail "Equipment Support Curb," number "SPF-9S" (page 1410). Install and secure centrifugal fans on curbs, and coordinate roof penetrations and flashing with roof construction. Secure units to curb support with anchor bolts.
- F. Curb Support, Prefabricated: Rail-type wood support provided by fan manufacturer.
- G. Unit Support: Install centrifugal fans level on structural curbs. Coordinate with duct connections. Coordinate wall penetrations and flashing with wall construction.
- H. Isolation Curb Support: Install centrifugal fans on isolation curbs, and install flexible duct connectors and vibration-isolation devices.
- I. Fan shall be provided with hurricane tie downs.
- J. Hurricane tie down attachment to roof shall be submitted for approval signed by a licensed engineer.

- K. Install units with clearances for service and maintenance.
- L. Label fans

3.2 DUCTWORK AND PIPING CONNECTIONS

- A. Install ducts adjacent to fans to allow service and maintenance.

3.3 ELECTRICAL CONNECTIONS

- A. Install electrical devices furnished by manufacturer, but not factory mounted, according to NFPA 70 and NECA 1.
- B. Install nameplate for each electrical connection, indicating electrical equipment designation and circuit number feeding connection.
 - 1. Nameplate shall be laminated acrylic or melamine plastic signs.
 - 2. Nameplate shall be laminated acrylic or melamine plastic signs with a black background and engraved white letters at least 1/2 inch (13 mm) high.

3.4 CONTROL CONNECTIONS

- A. Install control and electrical power wiring to field-mounted control devices.

3.5 STARTUP SERVICE:

- A. Engage a factory-authorized service representative to perform startup service.
 - 1. Complete installation and startup checks in accordance with manufacturer's written instructions.
 - 2. Verify that shipping, blocking, and bracing are removed.
 - 3. Verify that unit is secure on mountings and supporting devices and that connections to ducts and electrical components are complete. Verify that proper thermal-overload protection is installed in motors, starters, and disconnect switches.
 - 4. Verify that cleaning and adjusting are complete.
 - 5. For direct-drive fans, verify proper motor rotation direction and verify fan wheel free rotation and smooth bearing operation.
 - 6. For belt-drive fans, disconnect fan drive from motor, verify proper motor rotation direction, and verify fan wheel free rotation and smooth bearing operation. Reconnect fan drive system, align and adjust belts, and install belt guards.
 - 7. Adjust belt tension.
 - 8. Adjust damper linkages for proper damper operation.
 - 9. Verify lubrication for bearings and other moving parts.
 - 10. Verify that manual and automatic volume control and fire and smoke dampers in connected ductwork systems are in fully open position.
 - 11. Disable automatic temperature-control operators, energize motor and confirm proper motor rotation and unit operation, adjust fan to indicated rpm, and measure and record motor voltage and amperage.

12. Shut unit down and reconnect automatic temperature-control operators.
13. Remove and replace malfunctioning units and retest as specified above.

3.6 ADJUSTING

- A. Adjust damper linkages for proper damper operation.
- B. Lubricate bearings.

3.7 CLEANING

- A. After completing system installation and testing, adjusting, and balancing and after completing startup service, clean fans internally to remove foreign material and construction dirt and dust.

3.8 FIELD QUALITY CONTROL

- A. Testing Agency: Owner will engage a qualified testing agency to perform tests and inspections.
- B. Perform tests and inspections with the assistance of a factory-authorized service representative.
 1. Fan Operational Test: After electrical circuitry has been energized, start units to confirm proper motor rotation and unit operation.
 2. Test and adjust controls and safeties. Replace damaged and malfunctioning controls and equipment.
 3. Fans and components will be considered defective if they do not pass tests and inspections.
- C. Prepare test and inspection reports.

3.9 DEMONSTRATION

- A. Engage a factory-authorized service representative to train Owner's maintenance personnel to adjust, operate, and maintain centrifugal fans.

END OF SECTION 233416

SECTION 262416 - PANELBOARDS

PART 1 - GENERAL

1.1 SUMMARY

A. Section Includes:

1. Power panelboards.
2. Lighting and appliance branch-circuit panelboards.
3. Disconnecting and overcurrent protective devices.

B. Related Requirements:

1. Section 260010 "Supplemental Requirements for Electrical" for additional abbreviations, definitions, submittals, qualifications, testing agencies, and other Project requirements applicable to Work specified in this Section.
2. Section 260011 "Facility Performance Requirements for Electrical" for seismic-load, wind-load, acoustical, and other field conditions applicable to Work specified in this Section.

1.2 DEFINITIONS

A. GFEP: Ground-fault equipment protection.

B. VPR: Voltage protection rating.

1.3 ACTION SUBMITTALS

A. Product Data:

1. Power panelboards.
2. Lighting and appliance branch-circuit panelboards.
3. Load centers.
4. Electronic-grade panelboards.
5. Disconnecting and overcurrent protective devices.
6. Include materials, switching and overcurrent protective devices, SPDs, accessories, and components indicated.
7. Include dimensions and manufacturers' technical data on features, performance, electrical characteristics, ratings, and finishes.

B. Shop Drawings: For each panelboard and related equipment.

1. Include dimensioned plans, elevations, sections, and details.
2. Show tabulations of installed devices with nameplates, conductor termination sizes, equipment features, and ratings.

3. Detail enclosure types including mounting and anchorage, environmental protection, knockouts, corner treatments, covers and doors, gaskets, hinges, and locks.
4. Detail bus configuration, current, and voltage ratings.
5. Short-circuit current rating of panelboards and overcurrent protective devices.
6. Include evidence of listing, by qualified electrical testing laboratory recognized by authorities having jurisdiction, for series rating of installed devices.
7. Include evidence of listing, by qualified electrical testing laboratory recognized by authorities having jurisdiction, for SPD as installed in panelboard.
8. Detail features, characteristics, ratings, and factory settings of individual overcurrent protective devices and auxiliary components.
9. Include wiring diagrams for power, signal, and control wiring.
10. Key interlock scheme drawing and sequence of operations.
11. Include time-current coordination curves for each type and rating of overcurrent protective device included in panelboards. Submit on translucent log-log graph paper; include selectable ranges for each type of overcurrent protective device. Include Internet link for electronic access to downloadable PDF of coordination curves.

C. Field Quality-Control Submittals:

1. Field quality-control reports.

1.4 INFORMATIONAL SUBMITTALS

- A. Panelboard Schedules: For installation in panelboards.
- B. Manufacturers' Published Instructions: Record copy of official installation and testing instructions issued to Installer by manufacturer for the following:
 1. Recommended procedures for installing panelboards.
 2. Recommended torque settings for bolted connections on panelboards.
 3. Recommended temperature range for energizing panelboards.
- C. Sample warranties.

1.5 CLOSEOUT SUBMITTALS

- A. Warranty documentation.

1.6 MAINTENANCE MATERIAL SUBMITTALS

- A. Special Tools: Furnish to Owner proprietary equipment, keys, and software required to operate, maintain, repair, adjust, or implement future changes to panelboards, that are packaged with protective covering for storage on-site and identified with labels describing contents. Include the following:
 1. Portable Test Set: For testing functions of solid-state trip devices without removing from panelboard. Include relay and meter test plugs suitable for testing panelboard meters and switchboard class relays.

1.7 WARRANTY

- A. Special Installer Extended Warranty: Installer warrants that fabricated and installed panelboards perform in accordance with specified requirements and agrees to repair or replace components or products that fail to perform as specified within extended-warranty period.
 - 1. Extended-Warranty Period: Two years from date of Substantial Completion; full coverage for labor, materials, and equipment.
- B. Special Manufacturer Extended Warranty: Manufacturer warrants that panelboards perform in accordance with specified requirements and agrees to provide repair or replacement of components or products that fail to perform as specified within extended-warranty period.
 - 1. Initial Extended-Warranty Period: Three years from date of Substantial Completion; full coverage for labor, materials, and equipment.
 - 2. Follow-On Extended-Warranty Period: Five years from date of Substantial Completion; full coverage for materials only, free on board destination, freight prepaid.

PART 2 - PRODUCTS

2.1 DISCONNECTING AND OVERCURRENT PROTECTIVE DEVICES

- A. Manufacturers: Subject to compliance with requirements, available manufacturers offering products that may be incorporated into the Work.
- B. MCCB: Comply with UL 489, with interrupting capacity to meet available fault currents.
 - 1. Thermal-Magnetic Circuit Breakers:
 - a. Inverse time-current element for low-level overloads.
 - b. Instantaneous magnetic trip element for short circuits.
 - c. Adjustable magnetic trip setting for circuit-breaker frame sizes 250 A and larger.
 - 2. Adjustable Instantaneous-Trip Circuit Breakers: Magnetic trip element with front-mounted, field-adjustable trip setting.
 - 3. Electronic Trip Circuit Breakers:
 - a. RMS sensing.
 - b. Field-replaceable rating plug or electronic trip.
 - c. Digital display of settings, trip targets, and indicated metering displays.
 - d. Multi-button keypad to access programmable functions and monitored data.
 - e. Ten-event, trip-history log. Each trip event must be recorded with type, phase, and magnitude of fault that caused trip.
 - f. Integral test jack for connection to portable test set or laptop computer.
 - g. Field-Adjustable Settings:
 - 1) Instantaneous trip.
 - 2) Long- and short-time pickup levels.
 - 3) Long and short time adjustments.

- 4) Ground-fault pickup level, time delay, and I squared T response.
4. Current-Limiting Circuit Breakers: Frame sizes 400 A and smaller; let-through ratings less than NEMA FU 1, RK-5.
5. GFCI Circuit Breakers: Single- and double-pole configurations with Class A ground-fault protection (6 mA trip).
6. GFEP Circuit Breakers: Class B ground-fault protection (30 mA trip).
7. Arc-Fault Circuit Interrupter Circuit Breakers: Comply with UL 1699; 120/240 V, single-pole configuration.
8. Subfeed Circuit Breakers: Vertically mounted.
9. MCCB Features and Accessories:
 - a. Standard frame sizes, trip ratings, and number of poles.
 - b. Breaker handle indicates tripped status.
 - c. UL listed for reverse connection without restrictive line or load ratings.
 - d. Lugs: Mechanical style, suitable for number, size, trip ratings, and conductor materials.
 - e. Application Listing: Appropriate for application; Type SWD for switching fluorescent lighting loads; Type HID for feeding fluorescent and HID lighting circuits.
 - f. Ground-Fault Protection: Integrally mounted relay and trip unit with adjustable pickup and time-delay settings, push-to-test feature, and ground-fault indicator.
 - g. Communication Capability: Integral communication module with functions and features compatible with power monitoring and control system specified in Section 260913 "Electrical Power Monitoring and Control."
 - h. Shunt Trip: 120 V trip coil energized from separate circuit, set to trip at 75 percent of rated voltage.
 - i. Handle Padlocking Device: Fixed attachment, for locking circuit-breaker handle in on or off position.
 - j. Handle Clamp: Loose attachment, for holding circuit-breaker handle in on position.
- C. Fused Switch: NEMA KS 1, Type HD; clips to accommodate specified fuses; lockable handle.
 1. Fuses and Spare-Fuse Cabinet: Comply with requirements specified in Section 262813 "Fuses."

PART 3 - EXECUTION

3.1 INSTALLATION

- A. Comply with manufacturer's published instructions.
- B. Reference Standards:
 1. Panelboards: Unless more stringent requirements are specified in Contract Documents or manufacturers' published instructions, comply with NECA 407 and/or NEMA PB 1.1.
 2. Consult Architect for resolution of conflicting requirements.

C. Special Techniques:

1. Comply with mounting and anchoring requirements specified in Section 260548.16 "Seismic Controls for Electrical Systems."
2. Mount top of trim **7.5 ft (2.3 m)** above finished floor unless otherwise indicated.
3. Mount panelboard cabinet plumb and rigid without distortion of box.
4. Mount recessed panelboards with fronts uniformly flush with wall finish and mating with back box.
5. Install overcurrent protective devices and controllers not already factory installed.
 - a. Set field-adjustable, circuit-breaker trip ranges.
6. Make grounding connections and bond neutral for services and separately derived systems to ground. Make connections to grounding electrodes, separate grounds for isolated ground bars, and connections to separate ground bars.
7. Install filler plates in unused spaces.
8. Stub four **1 inch (25 mm)** empty conduits from panelboard into accessible ceiling space or space designated to be ceiling space in future. Stub four **1 inch (25 mm)** empty conduits into raised floor space or below slab not on grade.

3.2 IDENTIFICATION

- A. Identify field-installed conductors, interconnecting wiring, and components; install warning signs.
- B. Panelboard Nameplates: Label each panelboard with nameplate.
- C. Device Nameplates: Label each branch circuit device in power panelboards with nameplate.
- D. Install warning signs identifying source of remote circuit.
- E. Panelboard Label: Manufacturer's name and trademark, voltage, amperage, number of phases, and number of poles must be located on interior of panelboard door.
- F. Breaker Labels: Faceplate must list current rating, UL and IEC certification standards, and AIC rating.
- G. Circuit Directory:
 1. Provide directory card inside panelboard door, mounted in metal frame with transparent protective cover.
 - a. Circuit directory must identify specific purpose with detail sufficient to distinguish it from other circuits.
 2. Provide computer-generated circuit directory mounted inside panelboard door with transparent plastic protective cover.
 - a. Circuit directory must identify specific purpose with detail sufficient to distinguish it from other circuits.

3. Create directory to indicate installed circuit loads; incorporate Owner's final room designations. Obtain approval before installing. Handwritten directories are not acceptable. Install directory inside panelboard door.

3.3 FIELD QUALITY CONTROL

A. Acceptance Testing Preparation:

1. Test insulation resistance for each panelboard bus, component, connecting supply, feeder, and control circuit.
2. Test continuity of each circuit.

B. Field tests and inspections must be witnessed by architect, tenant and authorities having jurisdiction.

C. Tests and Inspections:

1. Perform each visual and mechanical inspection and electrical test for low-voltage air circuit breakers and low-voltage surge arrestors stated in NETA ATS, Paragraph 7.6 Circuit Breakers and Paragraph 7.19.1 Surge Arrestors, Low-Voltage. Perform optional tests. Certify compliance with test parameters.
2. Correct malfunctioning units on-site, where possible, and retest to demonstrate compliance; otherwise, replace with new units and retest.

D. Nonconforming Work:

1. Panelboards will be considered defective if they do not pass tests and inspections.
2. Remove and replace defective units and retest.

E. Collect, assemble, and submit test and inspection reports, including certified report that identifies panelboards included and that describes scanning results, with comparisons of two scans. Include notation of deficiencies detected, remedial action taken, and observations after remedial action.

F. Manufacturer Services:

1. Engage factory-authorized service representative to support field tests and inspections.

END OF SECTION 262416

SECTION 265619 - LED EXTERIOR LIGHTING

PART 1 - GENERAL

1.1 SUMMARY

A. Section Includes:

1. Exterior solid-state luminaires that are designed for and exclusively use LED lamp technology.
2. Luminaire supports.
3. Luminaire-mounted photoelectric relays.

1.2 DEFINITIONS

- A. CCT: Correlated color temperature.
- B. CRI: Color rendering index.
- C. Fixture: See "Luminaire."
- D. IP: International Protection or Ingress Protection Rating.
- E. Lumen: Measured output of lamp and luminaire, or both.
- F. Luminaire: Complete lighting unit, including lamp, reflector, and housing.

1.3 ACTION SUBMITTALS

- A. Product Data: For each type of luminaire.
- B. Shop Drawings: For nonstandard or custom luminaires.
 1. Include plans, elevations, sections, and mounting and attachment details.
 2. Include details of luminaire assemblies. Indicate dimensions, weights, loads, required clearances, method of field assembly, components, and location and size of each field connection.
 3. Include diagrams for power, signal, and control wiring.
- C. Delegated Design Submittals: For luminaire supports.
 1. Include design calculations for luminaire supports and seismic restraints.

1.4 INFORMATIONAL SUBMITTALS

- A. Coordination Drawings: Plans, drawn to scale and coordinated.

- B. Seismic Qualification Data: For luminaires, accessories, and components, from manufacturer.
- C. Product Certificates: For each type of the following:
 - 1. Luminaire.
 - 2. Photoelectric relay.
- D. Sample warranty.

1.5 CLOSEOUT SUBMITTALS

- A. Operation and maintenance data.
 - 1. Provide a list of all lamp types used on Project. Use ANSI and manufacturers' codes.
 - 2. Provide a list of all photoelectric relay types used on Project; use manufacturers' codes.

1.6 FIELD CONDITIONS

- A. Mark locations of exterior luminaires for approval by Architect prior to the start of luminaire installation.

1.7 WARRANTY

- A. Warranty: Manufacturer and Installer agree to repair or replace components of luminaires that fail in materials or workmanship within specified warranty period.
 - 1. Warranty Period: 5 year(s) from date of Substantial Completion.

PART 2 - PRODUCTS

2.1 PERFORMANCE REQUIREMENTS

- A. Seismic Performance: Luminaires and lamps shall be labeled vibration and shock resistant.

2.2 LUMINAIRE REQUIREMENTS

- A. Electrical Components, Devices, and Accessories: Listed and labeled as defined in NFPA 70, by a qualified testing agency, and marked for intended location and application.
- B. NRTL Compliance: Luminaires shall be listed and labeled for indicated class and division of hazard by an NRTL.
- C. FM Global Compliance: Luminaires for hazardous locations shall be listed and labeled for indicated class and division of hazard by FM Global.
- D. UL Compliance: Comply with UL 1598 and listed for wet location.

- E. Lamp base complying with ANSI C136.31.
- F. CRI of minimum 70. CCT of 4000K.
- G. L70 lamp life of >100,000 hours.
- H. Nominal Operating Voltage: 120 - 277 V ac.
- I. Lamp Rating: Lamp marked for outdoor use.
- J. Source Limitations:
 - 1. For luminaires, obtain each color, grade, finish, type, and variety of luminaire from single source with resources to provide products of consistent quality in appearance and physical properties.

2.3 LUMINAIRE TYPES

- A. Area and Site:
 - 1. Luminaire Shape: Rectangular, Equal or similar, Autobahn LED Series ATB0 27"x8", Cobra Head Lighting, 4000K, MVOLT 120-277V.
 - 2. Mounting: Building, wall mounted.

2.4 MATERIALS

- A. Metal Parts: Free of burrs and sharp corners and edges.
- B. Sheet Metal Components: Corrosion-resistant aluminum. Form and support to prevent warping and sagging.
- C. Doors, Frames, and Other Internal Access: Smooth operating, free of light leakage under operating conditions, and designed to permit relamping without use of tools. Designed to prevent doors, frames, lenses, diffusers, and other components from falling accidentally during relamping and when secured in operating position. Doors shall be removable for cleaning or replacing lenses.
- D. Diffusers and Globes:
 - 1. Acrylic Diffusers: 100 percent virgin acrylic plastic, with high resistance to yellowing and other changes due to aging, exposure to heat, and UV radiation.
- E. Lens and Refractor Gaskets: Use heat- and aging-resistant resilient gaskets to seal and cushion lenses and refractors in luminaire doors.
- F. Reflecting surfaces shall have minimum reflectance as follows unless otherwise indicated:
 - 1. White Surfaces: 85 percent.
 - 2. Specular Surfaces: 83 percent.
 - 3. Diffusing Specular Surfaces: 75 percent.

G. Housings:

1. Rigidly formed, weather- and light-tight enclosure that will not warp, sag, or deform in use.
2. Provide filter/breather for enclosed luminaires.

2.5 FINISHES

- A. Variations in Finishes: Noticeable variations in same piece are unacceptable. Variations in appearance of adjoining components are acceptable if they are within the range of approved Samples and are assembled or installed to minimize contrast.
- B. Luminaire Finish: Manufacturer's standard paint applied to factory-assembled and -tested luminaire before shipping. Where indicated, match finish process and color of pole or support materials.
- C. Factory-Applied Finish for Aluminum Luminaires: Comply with NAAMM's "Metal Finishes Manual for Architectural and Metal Products" for recommendations for applying and designating finishes.
1. Finish designations prefixed by AA comply with the system established by the Aluminum Association for designating aluminum finishes.
 - 1) As selected from manufacturer's standard catalog of colors.

PART 3 - EXECUTION

3.1 GENERAL INSTALLATION REQUIREMENTS

- A. Comply with NECA 1.
- B. Use fastening methods and materials selected to resist seismic forces defined for the application and approved by manufacturer.
- C. Install lamps in each luminaire.
- D. Fasten luminaire to structural support.
- E. Supports:
1. Sized and rated for luminaire weight.
 2. Able to maintain luminaire position after cleaning and relamping.
 3. Support luminaires without causing deflection of finished surface.
 4. Luminaire-mounting devices shall be capable of supporting a horizontal force of 100 percent of luminaire weight and a vertical force of 400 percent of luminaire weight.
- F. Wall-Mounted Luminaire Support:
1. Attached using through bolts and backing plates on either side of wall.

- G. Wiring Method: Install cables in raceways. Conceal raceways and cables.
- H. Install luminaires level, plumb, and square with finished grade unless otherwise indicated. Install luminaires at height and aiming angle as indicated on Drawings.
- I. Coordinate layout and installation of luminaires with other construction.
- J. Adjust luminaires that require field adjustment or aiming. Include adjustment of photoelectric device to prevent false operation of relay by artificial light sources, favoring a north orientation.

3.2 CORROSION PREVENTION

- A. Aluminum: Do not use in contact with earth or concrete. When in direct contact with a dissimilar metal, protect aluminum by insulating fittings or treatment.

3.3 FIELD QUALITY CONTROL

- A. Inspect each installed luminaire for damage. Replace damaged luminaires and components.
- B. Perform the following tests and inspections with the assistance of a factory-authorized service representative:
 - 1. Operational Test: After installing luminaires, switches, and accessories, and after electrical circuitry has been energized, test units to confirm proper operation.
 - 2. Photoelectric Control Operation: Verify operation of photoelectric controls.
- C. Luminaire will be considered defective if it does not pass tests and inspections.
- D. Prepare a written report of tests, inspections, observations, and verifications indicating and interpreting results. If adjustments are made to lighting system, retest to demonstrate compliance with standards.

3.4 DEMONSTRATION

- A. Train Owner's maintenance personnel to adjust, operate, and maintain luminaires and photocell relays.

END OF SECTION 265619

SECTION 311000 - SITE CLEARING

PART 1 - GENERAL

1.1 SUMMARY

A. Section Includes:

1. Protecting existing vegetation to remain.
2. Removing existing vegetation.
3. Clearing and grubbing.
4. Stripping and stockpiling topsoil.
5. Removing above- and below-grade site improvements.
6. Disconnecting, capping, or sealing site utilities.
7. Temporary erosion and sedimentation control.

1.2 PREINSTALLATION MEETINGS

- ##### A. Preinstallation Conference: Conduct conference at Project site.

1.3 MATERIAL OWNERSHIP

- ##### A. Except for materials indicated to be stockpiled or otherwise remain Owner's property, cleared materials shall become Contractor's property and shall be removed from Project site.

1.4 FIELD CONDITIONS

- ##### A. Traffic: Minimize interference with adjoining roads, streets, walks, and other adjacent occupied or used facilities during site-clearing operations.
1. Do not close or obstruct streets, walks, or other adjacent occupied or used facilities without permission from Owner and authorities having jurisdiction.
 2. Provide alternate routes around closed or obstructed trafficways if required by Owner or authorities having jurisdiction.
- ##### B. Salvageable Improvements: Carefully remove items indicated to be salvaged and store on Owner's premises where indicated.
- ##### C. Utility Locator Service: Notify utility locator service for area where Project is located before site clearing.
- ##### D. Do not commence site clearing operations until temporary erosion- and sedimentation-control and plant-protection measures are in place.
- ##### E. Tree- and Plant-Protection Zones: Protect according to requirements in Section 015639 "Temporary Tree and Plant Protection."

PART 2 - PRODUCTS

2.1 MATERIALS

- A. Satisfactory Soil Material: Requirements for satisfactory soil material are specified in Section 312000 "Earth Moving."
 - 1. Obtain approved borrow soil material off-site when satisfactory soil material is not available on-site.

PART 3 - EXECUTION

3.1 PREPARATION

- A. Protect and maintain benchmarks and survey control points from disturbance during construction.
- B. Verify that trees, shrubs, and other vegetation to remain or to be relocated have been flagged and that protection zones have been identified and enclosed according to requirements in Section 015639 "Temporary Tree and Plant Protection."
- C. Protect existing site improvements to remain from damage during construction.
 - 1. Restore damaged improvements to their original condition, as acceptable to Owner.

3.2 TEMPORARY EROSION AND SEDIMENTATION CONTROL

- A. Provide temporary erosion- and sedimentation-control measures to prevent soil erosion and discharge of soil-bearing water runoff or airborne dust to adjacent properties and walkways, according to erosion- and sedimentation-control Drawings and requirements of authorities having jurisdiction.
- B. Verify that flows of water redirected from construction areas or generated by construction activity do not enter or cross protection zones.
- C. Inspect, maintain, and repair erosion- and sedimentation-control measures during construction until permanent vegetation has been established.
- D. Remove erosion and sedimentation controls, and restore and stabilize areas disturbed during removal.

3.3 TREE AND PLANT PROTECTION

- A. Protect trees and plants remaining on-site.
- B. Repair or replace trees, shrubs, and other vegetation indicated to remain or be relocated that are damaged by construction operations.

3.4 EXISTING UTILITIES

- A. Locate, identify, disconnect, and seal or cap utilities indicated to be removed or abandoned in place.
 - 1. Arrange with utility companies to shut off indicated utilities.
- B. Interrupting Existing Utilities: Do not interrupt utilities serving facilities occupied by Owner or others, unless permitted under the following conditions and then only after arranging to provide temporary utility services according to requirements indicated:
 - 1. Notify Architect not less than two days in advance of proposed utility interruptions.
 - 2. Do not proceed with utility interruptions without Architect's written permission.
- C. Removal of underground utilities is included in earthwork sections; in applicable fire suppression, plumbing, HVAC, electrical, communications, electronic safety and security, and utilities sections; and in Section 024119 "Selective Demolition."

3.5 CLEARING AND GRUBBING

- A. Remove obstructions, trees, shrubs, and other vegetation to permit installation of new construction.
 - 1. Grind down stumps and remove roots larger than **3 inches (75 mm)** in diameter, obstructions, and debris to a depth of **18 inches (450 mm)** below exposed subgrade.
 - 2. Use only hand methods or air spade for grubbing within protection zones.
- B. Fill depressions caused by clearing and grubbing operations with satisfactory soil material unless further excavation or earthwork is indicated.
 - 1. Place fill material in horizontal layers not exceeding a loose depth of **8 inches (200 mm)**, and compact each layer to a density equal to adjacent original ground.

3.6 TOPSOIL STRIPPING

- A. Remove sod and grass before stripping topsoil.
- B. Strip topsoil to depth of **6 inches (150 mm)** in a manner to prevent intermingling with underlying subsoil or other waste materials.
- C. Stockpile topsoil away from edge of excavations without intermixing with subsoil or other materials. Grade and shape stockpiles to drain surface water. Cover to prevent windblown dust and erosion by water.

3.7 SITE IMPROVEMENTS

- A. Remove existing above- and below-grade improvements as indicated and necessary to facilitate new construction.

3.8 DISPOSAL OF SURPLUS AND WASTE MATERIALS

- A. Remove surplus soil material, unsuitable topsoil, obstructions, demolished materials, and waste materials including trash and debris, and legally dispose of them off Owner's property.
- B. Separate recyclable materials produced during site clearing from other nonrecyclable materials. Store or stockpile without intermixing with other materials, and transport them to recycling facilities. Do not interfere with other Project work.

END OF SECTION 311000

SECTION 312000 - EARTH MOVING

PART 1 - GENERAL

1.1 SUMMARY

A. Section Includes:

1. Excavating and filling for rough grading the Site.
2. Preparing subgrades for slabs-on-grade, walks, pavements, turf and grasses and plants.
3. Excavating and backfilling for buildings and structures.
4. Drainage course for concrete slabs-on-grade.
5. Subbase course for concrete walks, pavements.
6. Subbase course and base course for asphalt paving.
7. Excavating and backfilling trenches for utilities and pits for buried utility structures.

1.2 DEFINITIONS

A. Backfill: Soil material used to fill an excavation.

1. Initial Backfill: Backfill placed beside and over pipe in a trench, including haunches to support sides of pipe.
2. Final Backfill: Backfill placed over initial backfill to fill a trench.

B. Base Course: Aggregate layer placed between the subbase course and hot-mix asphalt paving.

C. Bedding Course: Aggregate layer placed over the excavated subgrade in a trench before laying pipe.

D. Borrow Soil: Satisfactory soil imported from off-site for use as fill or backfill.

E. Drainage Course: Aggregate layer supporting the slab-on-grade that also minimizes upward capillary flow of pore water.

F. Excavation: Removal of material encountered above subgrade elevations and to lines and dimensions indicated.

1. Authorized Additional Excavation: Excavation below subgrade elevations or beyond indicated lines and dimensions as directed by Architect. Authorized additional excavation and replacement material will be paid for according to Contract provisions for changes in the Work.
2. Unauthorized Excavation: Excavation below subgrade elevations or beyond indicated lines and dimensions without direction by Architect. Unauthorized excavation, as well as remedial work directed by Architect, will be without additional compensation.

G. Fill: Soil materials used to raise existing grades.

- H. Structures: Buildings, footings, foundations, retaining walls, slabs, tanks, curbs, mechanical and electrical appurtenances, or other fabricated stationary features constructed above or below the ground surface.
- I. Subbase Course: Aggregate layer placed between the subgrade and base course for hot-mix asphalt pavement, or aggregate layer placed between the subgrade and a cement concrete pavement or a cement concrete or hot-mix asphalt walk.
- J. Subgrade: Uppermost surface of an excavation or the top surface of a fill or backfill immediately below subbase, drainage fill, drainage course, or topsoil materials.
- K. Utilities: On-site underground pipes, conduits, ducts, and cables as well as underground services within buildings.

1.3 PREINSTALLATION MEETINGS

- A. Preinstallation Conference: Conduct preexcavation conference at Project site.

1.4 INFORMATIONAL SUBMITTALS

- A. Material test reports.

1.5 FIELD CONDITIONS

- A. Utility Locator Service: Notify utility locator service for area where Project is located before beginning earth-moving operations.
- B. Do not commence earth-moving operations until plant-protection measures specified in Section 015639 "Temporary Tree and Plant Protection" are in place.

PART 2 - PRODUCTS

2.1 SOIL MATERIALS

- A. General: Provide borrow soil materials when sufficient satisfactory soil materials are not available from excavations.
- B. Satisfactory Soils: Soil Classification Groups A-1, A-2-4, A-2-5, and A-3 according to AASHTO M 145, or a combination of these groups; free of rock or gravel larger than **3 inches (75 mm)** in any dimension, debris, waste, frozen materials, vegetation, and other deleterious matter.
- C. Unsatisfactory Soils: Soil Classification Groups A-2-6, A-2-7, A-4, A-5, A-6, and A-7 according to AASHTO M 145, or a combination of these groups.
 - 1. Unsatisfactory soils also include satisfactory soils not maintained within 2 percent of optimum moisture content at time of compaction.

- D. Subbase Material: Naturally or artificially graded mixture of natural or crushed gravel, crushed stone, and natural or crushed sand; ASTM D2940/D2940M; with at least 90 percent passing a 1-1/2-inch (37.5-mm) sieve and not more than 12 percent passing a No. 200 (0.075-mm) sieve.
- E. Base Course: Naturally or artificially graded mixture of natural or crushed gravel, crushed stone, and natural or crushed sand; ASTM D2940/D2940M; with at least 95 percent passing a 1-1/2-inch (37.5-mm) sieve and not more than 8 percent passing a No. 200 (0.075-mm) sieve.
- F. Engineered Fill: Naturally or artificially graded mixture of natural or crushed gravel, crushed stone, and natural or crushed sand; ASTM D2940/D2940M; with at least 90 percent passing a 1-1/2-inch (37.5-mm) sieve and not more than 12 percent passing a No. 200 (0.075-mm) sieve.
- G. Bedding Course: Naturally or artificially graded mixture of natural or crushed gravel, crushed stone, and natural or crushed sand; ASTM D2940/D2940M; except with 100 percent passing a 1-inch (25-mm) sieve and not more than 8 percent passing a No. 200 (0.075-mm) sieve.
- H. Drainage Course: Narrowly graded mixture of washed crushed stone, or crushed or uncrushed gravel; ASTM D448; coarse-aggregate grading Size 57; with 100 percent passing a 1-1/2-inch (37.5-mm) sieve and zero to 5 percent passing a No. 8 (2.36-mm) sieve.

2.2 ACCESSORIES

- A. Warning Tape: Acid- and alkali-resistant, polyethylene film warning tape manufactured for marking and identifying underground utilities, 6 inches (150 mm) wide and 4 mils (0.1 mm) thick, continuously inscribed with a description of the utility; colored to comply with local practice or requirements of authorities having jurisdiction.
- B. Detectable Warning Tape: Acid- and alkali-resistant, polyethylene film warning tape manufactured for marking and identifying underground utilities, a minimum of 6 inches (150 mm) wide and 4 mils (0.1 mm) thick, continuously inscribed with a description of the utility, with metallic core encased in a protective jacket for corrosion protection, detectable by metal detector when tape is buried up to 30 inches (750 mm) deep; colored to comply with local practice or requirements of authorities having jurisdiction.

PART 3 - EXECUTION

3.1 PREPARATION

- A. Protect structures, utilities, sidewalks, pavements, and other facilities from damage caused by settlement, lateral movement, undermining, washout, and other hazards created by earth-moving operations.
- B. Protect and maintain erosion and sedimentation controls during earth-moving operations.
- C. Protect subgrades and foundation soils from freezing temperatures and frost. Remove temporary protection before placing subsequent materials.

3.2 EXCAVATION, GENERAL

- A. Unclassified Excavation: Excavate to subgrade elevations regardless of the character of surface and subsurface conditions encountered. Unclassified excavated materials may include rock, soil materials, and obstructions. No changes in the Contract Sum or the Contract Time will be authorized for rock excavation or removal of obstructions.
 - 1. If excavated materials intended for fill and backfill include unsatisfactory soil materials and rock, replace with satisfactory soil materials.

3.3 EXCAVATION FOR STRUCTURES

- A. Excavate to indicated elevations and dimensions within a tolerance of plus or minus **1 inch (25 mm)**. If applicable, extend excavations a sufficient distance from structures for placing and removing concrete formwork, for installing services and other construction, and for inspections.
 - 1. Excavations for Footings and Foundations: Do not disturb bottom of excavation. Excavate by hand to final grade just before placing concrete reinforcement. Trim bottoms to required lines and grades to leave solid base to receive other work.
 - 2. Pile Foundations: Stop excavations **6 to 12 inches (150 to 300 mm)** above bottom of pile cap before piles are placed. After piles have been driven, remove loose and displaced material. Excavate to final grade, leaving solid base to receive concrete pile caps.
 - 3. Excavation for Underground Tanks, Basins, and Mechanical or Electrical Utility Structures: Excavate to elevations and dimensions indicated within a tolerance of plus or minus **1 inch (25 mm)**. Do not disturb bottom of excavations intended as bearing surfaces.
- B. Excavations at Edges of Tree- and Plant-Protection Zones:
 - 1. Excavate by hand or with an air spade to indicated lines, cross sections, elevations, and subgrades. If excavating by hand, use narrow-tine spading forks to comb soil and expose roots. Do not break, tear, or chop exposed roots. Do not use mechanical equipment that rips, tears, or pulls roots.
 - 2. Cut and protect roots according to requirements in Section 015639 "Temporary Tree and Plant Protection."

3.4 EXCAVATION FOR WALKS AND PAVEMENTS

- A. Excavate surfaces under walks and pavements to indicated lines, cross sections, elevations, and subgrades.

3.5 EXCAVATION FOR UTILITY TRENCHES

- A. Excavate trenches to indicated gradients, lines, depths, and elevations.
- B. Excavate trenches to uniform widths to provide the following clearance on each side of pipe or conduit. Excavate trench walls vertically from trench bottom to **12 inches (300 mm)** higher than top of pipe or conduit unless otherwise indicated.

1. Clearance: 12 inches (300 mm) each side of pipe or conduit.
- C. Trench Bottoms: Excavate and shape trench bottoms to provide uniform bearing and support of pipes and conduit. Shape subgrade to provide continuous support for bells, joints, and barrels of pipes and for joints, fittings, and bodies of conduits. Remove projecting stones and sharp objects along trench subgrade.
1. Excavate trenches 6 inches (150 mm) deeper than elevation required in rock or other unyielding bearing material to allow for bedding course.
- D. Trenches in Tree- and Plant-Protection Zones:
1. Hand-excavate to indicated lines, cross sections, elevations, and subgrades. Use narrow-tine spading forks to comb soil and expose roots. Do not break, tear, or chop exposed roots. Do not use mechanical equipment that rips, tears, or pulls roots.
 2. Do not cut main lateral roots or taproots; cut only smaller roots that interfere with installation of utilities.
 3. Cut and protect roots according to requirements in Section 015639 "Temporary Tree and Plant Protection."

3.6 SUBGRADE INSPECTION

- A. Proof-roll subgrade below the building slabs and pavements with a pneumatic-tired dump truck to identify soft pockets and areas of excess yielding. Do not proof-roll wet or saturated subgrades.
- B. Reconstruct subgrades damaged by freezing temperatures, frost, rain, accumulated water, or construction activities, as directed by Architect, without additional compensation.

3.7 UNAUTHORIZED EXCAVATION

- A. Fill unauthorized excavation under foundations or wall footings by extending bottom elevation of concrete foundation or footing to excavation bottom, without altering top elevation. Lean concrete fill, with 28-day compressive strength of 2500 psi (17.2 MPa), may be used when approved by Architect.
1. Fill unauthorized excavations under other construction, pipe, or conduit as directed by Architect.

3.8 STORAGE OF SOIL MATERIALS

- A. Stockpile borrow soil materials and excavated satisfactory soil materials without intermixing. Place, grade, and shape stockpiles to drain surface water. Cover to prevent windblown dust.
1. Stockpile soil materials away from edge of excavations. Do not store within drip line of remaining trees.

3.9 BACKFILL

- A. Place and compact backfill in excavations promptly, but not before completing the following:
 - 1. Construction below finish grade.
 - 2. Surveying locations of underground utilities for Record Documents.
 - 3. Testing and inspecting underground utilities.
 - 4. Removing concrete formwork.
 - 5. Removing trash and debris.
 - 6. Removing temporary shoring, bracing, and sheeting.
 - 7. Installing permanent or temporary horizontal bracing on horizontally supported walls.
- B. Place backfill on subgrades free of mud, frost, snow, or ice.

3.10 UTILITY TRENCH BACKFILL

- A. Place backfill on subgrades free of mud, frost, snow, or ice.
- B. Place and compact bedding course on trench bottoms and where indicated. Shape bedding course to provide continuous support for bells, joints, and barrels of pipes and for joints, fittings, and bodies of conduits.
- C. Trenches under Footings: Backfill trenches excavated under footings and within **18 inches (450 mm)** of bottom of footings with satisfactory soil; fill with concrete to elevation of bottom of footings. Concrete is specified in Section 033000 "Cast-in-Place Concrete."
- D. Trenches under Roadways: Provide **4-inch- (100-mm-)** thick, concrete-base slab support for piping or conduit less than **30 inches (750 mm)** below surface of roadways. After installing and testing, completely encase piping or conduit in a minimum of **4 inches (100 mm)** of concrete before backfilling or placing roadway subbase course. Concrete is specified in Section 033000 "Cast-in-Place Concrete."
- E. Initial Backfill: Place and compact initial backfill of subbase material and satisfactory soil, free of particles larger than **1 inch (25 mm)** in any dimension, to a height of **12 inches (300 mm)** over the pipe or conduit.
 - 1. Carefully compact initial backfill under pipe haunches and compact evenly up on both sides and along the full length of piping or conduit to avoid damage or displacement of piping or conduit. Coordinate backfilling with utilities testing.
- F. Final Backfill: Place and compact final backfill of satisfactory soil to final subgrade elevation.
- G. Warning Tape: Install warning tape directly above utilities, **12 inches (300 mm)** below finished grade, except **6 inches (150 mm)** below subgrade under pavements and slabs.

3.11 SOIL FILL

- A. Plow, scarify, bench, or break up sloped surfaces steeper than 1 vertical to 4 horizontal so fill material will bond with existing material.

B. Place and compact fill material in layers to required elevations as follows:

1. Under grass and planted areas, use satisfactory soil material.
2. Under walks and pavements, use satisfactory soil material.
3. Under steps and ramps, use engineered fill.
4. Under building slabs, use engineered fill.
5. Under footings and foundations, use engineered fill.

3.12 SOIL MOISTURE CONTROL

A. Uniformly moisten or aerate subgrade and each subsequent fill or backfill soil layer before compaction to within 2 percent of optimum moisture content.

1. Do not place backfill or fill soil material on surfaces that are muddy, frozen, or contain frost or ice.
2. Remove and replace, or scarify and air dry, otherwise satisfactory soil material that exceeds optimum moisture content by 2 percent and is too wet to compact to specified dry unit weight.

3.13 COMPACTION OF SOIL BACKFILLS AND FILLS

A. Place backfill and fill soil materials in layers not more than **8 inches (200 mm)** in loose depth for material compacted by heavy compaction equipment and not more than **4 inches (100 mm)** in loose depth for material compacted by hand-operated tampers.

B. Place backfill and fill soil materials evenly on all sides of structures to required elevations and uniformly along the full length of each structure.

C. Compact soil materials to not less than the following percentages of maximum dry unit weight according to ASTM D1557:

1. Under structures, building slabs, steps, and pavements, scarify and recompact top **12 inches (300 mm)** of existing subgrade and each layer of backfill or fill soil material at 95 percent.
2. Under walkways, scarify and recompact top **6 inches (150 mm)** below subgrade and compact each layer of backfill or fill soil material at 92 percent.
3. Under turf or unpaved areas, scarify and recompact top **6 inches (150 mm)** below subgrade and compact each layer of backfill or fill soil material at 85 percent.
4. For utility trenches, compact each layer of initial and final backfill soil material at 85 percent.

3.14 GRADING

A. General: Uniformly grade areas to a smooth surface, free of irregular surface changes. Comply with compaction requirements and grade to cross sections, lines, and elevations indicated.

- B. Site Rough Grading: Slope grades to direct water away from buildings and to prevent ponding. Finish subgrades to elevations required to achieve indicated finish elevations, within the following subgrade tolerances:
 - 1. Turf or Unpaved Areas: Plus or minus 1 inch (25 mm).
 - 2. Walks: Plus or minus 1 inch (25 mm).
 - 3. Pavements: Plus or minus 1/2 inch (13 mm).
- C. Grading inside Building Lines: Finish subgrade to a tolerance of 1/2 inch (13 mm) when tested with a 10-foot (3-m) straightedge.

3.15 SUBBASE AND BASE COURSES UNDER PAVEMENTS AND WALKS

- A. Place subbase course and base course on subgrades free of mud, frost, snow, or ice.
- B. On prepared subgrade, place subbase course and base course under pavements and walks as follows:
 - 1. Shape subbase course and base course to required crown elevations and cross-slope grades.
 - 2. Place subbase course and base course that exceeds 6 inches (150 mm) in compacted thickness in layers of equal thickness, with no compacted layer more than 6 inches (150 mm) thick or less than 3 inches (75 mm) thick.
 - 3. Compact subbase course and base course at optimum moisture content to required grades, lines, cross sections, and thickness to not less than 95 percent of maximum dry unit weight according to ASTM D1557.

3.16 DRAINAGE COURSE UNDER CONCRETE SLABS-ON-GRADE

- A. Place drainage course on subgrades free of mud, frost, snow, or ice.
- B. On prepared subgrade, place and compact drainage course under cast-in-place concrete slabs-on-grade as follows:
 - 1. Place drainage course that exceeds 6 inches (150 mm) in compacted thickness in layers of equal thickness, with no compacted layer more than 6 inches (150 mm) thick or less than 3 inches (75 mm) thick.
 - 2. Compact each layer of drainage course to required cross sections and thicknesses to not less than 95 percent of maximum dry unit weight according to ASTM D698.

3.17 FIELD QUALITY CONTROL

- A. Special Inspections: Owner will engage a qualified special inspector to perform inspections:
- B. Testing Agency: Owner will engage a qualified geotechnical engineering testing agency to perform tests and inspections.

- C. Allow testing agency to inspect and test subgrades and each fill or backfill layer. Proceed with subsequent earth moving only after test results for previously completed work comply with requirements.
- D. Footing Subgrade: At footing subgrades, at least one test of each soil stratum will be performed to verify design bearing capacities. Subsequent verification and approval of other footing subgrades may be based on a visual comparison of subgrade with tested subgrade when approved by Architect.
- E. When testing agency reports that subgrades, fills, or backfills have not achieved degree of compaction specified, scarify and moisten or aerate, or remove and replace soil materials to depth required; recompact and retest until specified compaction is obtained.

3.18 PROTECTION

- A. Protecting Graded Areas: Protect newly graded areas from traffic, freezing, and erosion. Keep free of trash and debris.
- B. Repair and reestablish grades to specified tolerances where completed or partially completed surfaces become eroded, rutted, settled, or where they lose compaction due to subsequent construction operations or weather conditions.
- C. Where settling occurs before Project correction period elapses, remove finished surfacing, backfill with additional soil material, compact, and reconstruct surfacing.
 - 1. Restore appearance, quality, and condition of finished surfacing to match adjacent work, and eliminate evidence of restoration to greatest extent possible.

3.19 DISPOSAL OF SURPLUS AND WASTE MATERIALS

- A. Remove surplus satisfactory soil and waste materials, including unsatisfactory soil, trash, and debris, and legally dispose of them off Owner's property.

END OF SECTION 312000

SECTION 321216 - ASPHALT PAVING

PART 1 - GENERAL

1.1 SUMMARY

A. Section Includes:

1. Hot-mix asphalt paving.
2. Hot-mix asphalt overlay.
3. Cold milling of existing asphalt pavement.
4. Hot-mix asphalt patching.
5. Asphalt curbs.

B. Related Requirements:

1. Section 312000 "Earth Moving" for subgrade preparation, fill material, separation geotextiles, unbound-aggregate subbase and base courses, and aggregate pavement shoulders.
2. Section 321313 "Concrete Paving" for concrete pavement and for separate concrete curbs, gutters, and driveway aprons.

1.2 PREINSTALLATION MEETINGS

- ##### A. Preinstallation Conference: Conduct conference at Project site.

1.3 ACTION SUBMITTALS

A. Product Data:

1. Herbicide.

B. Hot-mix asphalt designs.

C. Sustainable Design Submittals:

1. Product Data: For recycled content, indicating postconsumer and preconsumer recycled content and cost.

1.4 INFORMATIONAL SUBMITTALS

A. Material Certificates:

1. Aggregates.
2. Asphalt binder.
3. Tack coat.

1.5 QUALITY ASSURANCE

- A. Regulatory Requirements: Comply with materials, workmanship, and other applicable requirements of the Puerto Rico Highway and Transportation Authority (PRTHA) or Municipality for asphalt paving work.
 - 1. Measurement and payment provisions and safety program submittals included in standard specifications do not apply to this Section.

PART 2 - PRODUCTS

2.1 AGGREGATES

- A. Coarse Aggregate: ASTM D692/D692M, sound; angular crushed stone, crushed gravel, or cured, crushed blast-furnace slag.
- B. Fine Aggregate: ASTM D1073 or AASHTO M 29, sharp-edged natural sand or sand prepared from stone, gravel, cured blast-furnace slag, or combinations thereof.
- C. Mineral Filler: ASTM D242/D242M or AASHTO M 17, rock or slag dust, hydraulic cement, or other inert material.

2.2 ASPHALT MATERIALS

- A. Asphalt Binder: ASTM D6373 or AASHTO M 320 binder designation PG 70-22.
- B. Asphalt Cement: ASTM D946/D946M for penetration-graded material.
- C. Tack Coat: ASTM D977 or AASHTO M 140 emulsified asphalt, or ASTM D2397/D2397M or AASHTO M 208 cationic emulsified asphalt, slow setting, diluted in water, of suitable grade and consistency for application.

2.3 AUXILIARY MATERIALS

- A. Recycled Materials for Hot-Mix Asphalt Mixes: Reclaimed asphalt pavement; reclaimed, unbound-aggregate base material; and recycled tires from sources and gradations that have performed satisfactorily in previous installations, equal to performance of required hot-mix asphalt paving produced from all new materials.
- B. Herbicide: Commercial chemical for weed control, registered by the EPA, and not classified as "restricted use" for locations and conditions of application. Provide in granular, liquid, or wettable powder form.

2.4 MIXES

- A. Recycled Content of Hot-Mix Asphalt: Postconsumer recycled content plus one-half of preconsumer recycled content not less than 20 percent or more than 25 percent by weight.

1. Surface Course Limit: Recycled content no more than 10 percent by weight.
- B. Hot-Mix Asphalt: Dense-graded, hot-laid, hot-mix asphalt plant mixes PRTHA; designed in accordance with procedures in AI MS-2, "Asphalt Mix Design Methods"; and complying with the following requirements:
 1. Provide mixes with a history of satisfactory performance in geographical area where Project is located.

PART 3 - EXECUTION

3.1 COLD MILLING

- A. Clean existing pavement surface of loose and deleterious material immediately before cold milling. Remove existing asphalt pavement by cold milling to grades and cross sections indicated.
 1. Mill to a depth of **3 inches (75 mm)**.
 2. Patch surface depressions deeper than **1 inch (25 mm)** after milling, before wearing course is laid.

3.2 PATCHING

- A. Asphalt Pavement: Saw cut perimeter of patch and excavate existing pavement section to sound base. Excavate rectangular or trapezoidal patches, extending **12 inches (300 mm)** into perimeter of adjacent sound pavement, unless otherwise indicated. Cut excavation faces vertically. Remove excavated material. Recompact existing unbound-aggregate base course to form new subgrade.
- B. Portland Cement Concrete Pavement: Break cracked slabs and roll as required to reseal concrete pieces firmly.
 1. Remove disintegrated or badly cracked pavement. Excavate rectangular or trapezoidal patches, extending into perimeter of adjacent sound pavement, unless otherwise indicated. Cut excavation faces vertically. Recompact existing unbound-aggregate base course to form new subgrade.
- C. Tack Coat: Before placing patch material, apply tack coat uniformly to vertical asphalt surfaces abutting the patch. Apply at a rate of **0.05 to 0.15 gal./sq. yd. (0.2 to 0.7 L/sq. m)**.
 1. Allow tack coat to cure undisturbed before applying hot-mix asphalt paving.
 2. Avoid smearing or staining adjoining surfaces, appurtenances, and surroundings. Remove spillages and clean affected surfaces.
- D. Placing Patch Material: Fill excavated pavement areas with hot-mix asphalt base mix for full thickness of patch and, while still hot, compact flush with adjacent surface.

3.3 SURFACE PREPARATION

- A. Ensure that prepared subgrade is ready to receive paving. Immediately before placing asphalt materials, remove loose and deleterious material from substrate surfaces.
- B. Herbicide Treatment: Apply herbicide in accordance with manufacturer's recommended rates and written application instructions. Apply to dry, prepared subgrade or surface of compacted-aggregate base before applying paving materials.
 - 1. Mix herbicide with prime coat if formulated by manufacturer for that purpose.
- C. Tack Coat: Apply uniformly to surfaces of existing pavement at a rate of **0.05 to 0.15 gal./sq. yd. (0.2 to 0.7 L/sq. m)**.
 - 1. Allow tack coat to cure undisturbed before applying hot-mix asphalt paving.
 - 2. Avoid smearing or staining adjoining surfaces, appurtenances, and surroundings. Remove spillages and clean affected surfaces.

3.4 HOT-MIX ASPHALT PLACEMENT

- A. Machine place hot-mix asphalt on prepared surface, spread uniformly, and strike off. Place asphalt mix by hand in areas inaccessible to equipment in a manner that prevents segregation of mix. Place each course to required grade, cross section, and thickness when compacted.
 - 1. Place hot-mix asphalt base course and binder course in number of lifts and thicknesses indicated.
 - 2. Place hot-mix asphalt surface course in single lift.
 - 3. Spread mix at a minimum temperature of **250 deg F (121 deg C)**.
 - 4. Regulate paver machine speed to obtain smooth, continuous surface free of pulls and tears in asphalt-paving mat.
- B. Place paving in consecutive strips not less than **10 feet (3 m)** wide unless infill edge strips of a lesser width are required.
- C. Promptly correct surface irregularities in paving course behind paver. Use suitable hand tools to remove excess material forming high spots. Fill depressions with hot-mix asphalt to prevent segregation of mix; use suitable hand tools to smooth surface.

3.5 JOINTS

- A. Construct joints to ensure a continuous bond between adjoining paving sections. Construct joints free of depressions, with same texture and smoothness as other sections of hot-mix asphalt course.
 - 1. Clean contact surfaces and apply tack coat to joints.
 - 2. Offset longitudinal joints, in successive courses, a minimum of **6 inches (150 mm)**.
 - 3. Offset transverse joints, in successive courses, a minimum of **24 inches (600 mm)**.
 - 4. Construct transverse joints at each point where paver ends a day's work and resumes work at a subsequent time. Construct these joints using either "bulkhead" or "papered"

method in accordance with AI MS-22, for both "Ending a Lane" and "Resumption of Paving Operations.

3.6 COMPACTION

- A. General: Begin compaction as soon as placed hot-mix paving will bear roller weight without excessive displacement. Compact hot-mix paving with hot hand tampers or with vibratory-plate compactors in areas inaccessible to rollers.
 - 1. Complete compaction before mix temperature cools to 185 deg F (85 deg C).
- B. Breakdown Rolling: Complete breakdown or initial rolling immediately after rolling joints and outside edge. Examine surface immediately after breakdown rolling for indicated crown, grade, and smoothness. Correct laydown and rolling operations to comply with requirements.
- C. Intermediate Rolling: Begin intermediate rolling immediately after breakdown rolling while hot-mix asphalt is still hot enough to achieve specified density. Continue rolling until hot-mix asphalt course has been uniformly compacted to the following density:
 - 1. Average Density, Rice Test Method: 92 percent of reference maximum theoretical density in accordance with ASTM D2041/D2041M, but not less than 90 percent or greater than 96 percent.
- D. Finish Rolling: Finish roll paved surfaces to remove roller marks while hot-mix asphalt is still warm.
- E. Edge Shaping: While surface is being compacted and finished, trim edges of pavement to proper alignment. Bevel edges while asphalt is still hot; compact thoroughly.
- F. Protection: After final rolling, do not permit vehicular traffic on pavement until it has cooled and hardened.
- G. Erect barricades to protect paving from traffic until mixture has cooled enough not to become marked.

3.7 ASPHALT CURBS

- A. Construct hot-mix asphalt curbs over compacted pavement surfaces. Apply a light tack coat unless pavement surface is still tacky and free from dust. Spread hot-mix asphalt at a minimum temperature of 250 deg F (121 deg C).
 - 1. Hot-Mix Asphalt: Same as pavement surface-course mix.
- B. Place hot-mix asphalt to curb cross section indicated or, if not indicated, to local standard shapes, by machine or by hand in wood or metal forms. Tamp hand-placed materials and screed to smooth finish. Remove forms after hot-mix asphalt has cooled.

3.8 INSTALLATION TOLERANCES

- A. Pavement Thickness: Compact each course to produce thickness indicated within the following tolerances:
 - 1. Base Course and Binder Course: Plus or minus 1/2 inch (13 mm).
 - 2. Surface Course: Plus 1/4 inch (6 mm), no minus.
- B. Pavement Surface Smoothness: Compact each course to produce surface smoothness within the following tolerances as determined by using a 10-foot (3-m) straightedge applied transversely or longitudinally to paved areas:
 - 1. Base Course and Binder Course: 1/4 inch (6 mm).
 - 2. Surface Course: 1/8 inch (3 mm).
 - 3. Crowned Surfaces: Test with crowned template centered and at right angle to crown. Maximum allowable variance from template is 1/4 inch (6 mm).

3.9 FIELD QUALITY CONTROL

- A. Testing Agency: Owner will engage a qualified testing agency to perform tests and inspections.
- B. Replace and compact hot-mix asphalt where core tests were taken.
- C. Remove and replace or install additional hot-mix asphalt where test results or measurements indicate that it does not comply with specified requirements.

3.10 WASTE HANDLING

- A. General: Handle asphalt-paving waste in accordance with approved waste management plan required in Section 017419 "Construction Waste Management and Disposal."

END OF SECTION 321216

SECTION 321313 - CONCRETE PAVING

PART 1 - GENERAL

1.1 SUMMARY

A. Section includes concrete paving, including the following:

1. Driveways.
2. Roadways.
3. Parking lots.
4. Curbs and gutters.
5. Walks.

1.2 ACTION SUBMITTALS

- A. Product Data: For each type of product.
- B. Sustainable Design Submittals:
- C. Samples: For each type of product, ingredient, or admixture requiring color selection.
- D. Design Mixtures: For each concrete paving mixture. Include alternate design mixtures when characteristics of materials, Project conditions, weather, test results, or other circumstances warrant adjustments.

1.3 QUALITY ASSURANCE

- A. Ready-Mix-Concrete Manufacturer Qualifications: A firm experienced in manufacturing ready-mixed concrete products and that complies with ASTM C94/C94M requirements for production facilities and equipment.
1. Manufacturer certified according to NRMCA's "Certification of Ready Mixed Concrete Production Facilities" (Quality Control Manual - Section 3, "Plant Certification Checklist").

1.4 PRECONSTRUCTION TESTING

- A. Preconstruction Testing Service: Engage a qualified independent testing agency to perform preconstruction testing on concrete paving mixtures.

PART 2 - PRODUCTS

2.1 CONCRETE, GENERAL

- A. ACI Publications: Comply with **ACI 301 (ACI 301M)** unless otherwise indicated.

2.2 STEEL REINFORCEMENT

- A. Plain-Steel Welded-Wire Reinforcement: ASTM A1064/A1064M, fabricated from as-drawn steel wire into flat sheets.
- B. Deformed-Steel Welded-Wire Reinforcement: ASTM A1064/A1064M, flat sheet.
- C. Reinforcing Bars: ASTM A615/A615M, **Grade 60 (Grade 420)**; deformed.
- D. Joint Dowel Bars: ASTM A615/A615M, **Grade 60 (Grade 420)** plain-steel bars; zinc coated (galvanized) after fabrication according to ASTM A767/A767M, Class I coating. Cut bars true to length with ends square and free of burrs.
- E. Bar Supports: Bolsters, chairs, spacers, and other devices for spacing, supporting, and fastening reinforcing bars, welded-wire reinforcement, and dowels in place. Manufacture bar supports according to CRSI's "Manual of Standard Practice" from steel wire, plastic, or precast concrete of greater compressive strength than concrete specified.

2.3 CONCRETE MATERIALS

- A. Cementitious Materials: Use the following cementitious materials, of same type, brand, and source throughout Project:
 - 1. Portland Cement: ASTM C150/C150M, gray portland cement Type III.
- B. Normal-Weight Aggregates: ASTM C33/C33M, Class 4S, Class 4M, Class 1N, uniformly graded. Provide aggregates from a single source.
- C. Air-Entraining Admixture: ASTM C260/C260M.
- D. Chemical Admixtures: Admixtures certified by manufacturer to be compatible with other admixtures and to contain not more than 0.1 percent water-soluble chloride ions by mass of cementitious material.
- E. Water: Potable and complying with ASTM C94/C94M.

2.4 FIBER REINFORCEMENT

- A. Synthetic Fiber, Monofilament Fibers: Monofilament polypropylene fibers engineered and designed for use in decorative concrete paving, complying with ASTM C1116/C1116M, Type III, **1/2 to 1-1/2 inches (13 to 38 mm)** long.

- B. Synthetic Fiber, Fibrillated Fibers: Fibrillated polypropylene fibers engineered and designed for use in decorative concrete paving, complying with ASTM C1116/C1116M, Type III, 1/2 to 1-1/2 inches (13 to 38 mm) long.

2.5 CURING MATERIALS

- A. Absorptive Cover: AASHTO M 182, Class 3, burlap cloth made from jute or kenaf, weighing approximately 9 oz./sq. yd. (305 g/sq. m) dry.
- B. Moisture-Retaining Cover: ASTM C171, polyethylene film or white burlap-polyethylene sheet.
- C. Water: Potable.
- D. Evaporation Retarder: Waterborne, monomolecular, film forming, manufactured for application to fresh concrete.
- E. Clear, Waterborne, Membrane-Forming Curing Compound: ASTM C309, Type 1, Class B, dissipating.
- F. White, Waterborne, Membrane-Forming Curing Compound: ASTM C309, Type 2, Class B, dissipating.

2.6 RELATED MATERIALS

- A. Joint Fillers: ASTM D8139, semirigid, closed-cell polypropylene foam in preformed strips.
- B. Slip-Resistive Aggregate Finish: Factory-graded, packaged, rustproof, nonglazing, abrasive aggregate of fused aluminum-oxide granules or crushed emery aggregate containing not less than 50 percent aluminum oxide and not less than 20 percent ferric oxide; unaffected by freezing, moisture, and cleaning materials.

2.7 CONCRETE MIXTURES

- A. Prepare design mixtures, proportioned according to ACI 301 (ACI 301M), for each type and strength of normal-weight concrete, and as determined by either laboratory trial mixtures or field experience.
- B. Cementitious Materials: Limit percentage, by weight, of cementitious materials other than portland cement in concrete as follows:
 - 1. Fly Ash or Pozzolan: 25 percent.
 - 2. Slag Cement: 50 percent.
 - 3. Combined Fly Ash or Pozzolan, and Slag Cement: 50 percent, with fly ash or pozzolan not exceeding 25 percent.
- C. Add air-entraining admixture at manufacturer's prescribed rate to result in normal-weight concrete at point of placement having an air content as follows:
 - 1. Air Content: 6 percent plus or minus 1-1/2 percent.

- D. Chemical Admixtures: Use admixtures according to manufacturer's written instructions.
- E. Synthetic Fiber: Uniformly disperse in concrete mixture at manufacturer's recommended rate, but not less than 1.0 lb/cu. yd. (0.60 kg/cu. m).
- F. Color Pigment: Add color pigment to concrete mixture according to manufacturer's written instructions and to result in hardened concrete color consistent with approved mockup.
- G. Concrete Mixtures: Normal-weight concrete.
 - 1. Compressive Strength (28 Days): 4000 psi (27.6 MPa).
 - 2. Maximum W/C Ratio at Point of Placement: 0.45 Insert ratio.
 - 3. Slump Limit: 4 inches (100 mm), plus or minus 1 inch (25 mm).

2.8 CONCRETE MIXING

- A. Ready-Mixed Concrete: Measure, batch, and mix concrete materials and concrete according to ASTM C94/C94M and ASTM C1116/C1116M. Furnish batch certificates for each batch discharged and used in the Work.

PART 3 - EXECUTION

3.1 EXAMINATION

- A. Proof-roll prepared subbase surface below concrete paving to identify soft pockets and areas of excess yielding.

3.2 PREPARATION

- A. Remove loose material from compacted subbase surface immediately before placing concrete.

3.3 EDGE FORMS AND SCREED CONSTRUCTION

- A. Set, brace, and secure edge forms, bulkheads, and intermediate screed guides to required lines, grades, and elevations. Install forms to allow continuous progress of work and so forms can remain in place at least 24 hours after concrete placement.
- B. Clean forms after each use and coat with form-release agent to ensure separation from concrete without damage.

3.4 INSTALLATION OF STEEL REINFORCEMENT

- A. Comply with CRSI's "Manual of Standard Practice" for fabricating, placing, and supporting reinforcement.

3.5 JOINTS

- A. General: Form construction, isolation, and contraction joints and tool edges true to line, with faces perpendicular to surface plane of concrete. Construct transverse joints at right angles to centerline unless otherwise indicated.
- B. Construction Joints: Set construction joints at side and end terminations of paving and at locations where paving operations are stopped for more than one-half hour unless paving terminates at isolation joints.
- C. Isolation Joints: Form isolation joints of preformed joint-filler strips abutting concrete curbs, catch basins, manholes, inlets, structures, other fixed objects, and where indicated.
- D. Contraction Joints: Form weakened-plane contraction joints, sectioning concrete into areas as indicated. Construct contraction joints for a depth equal to at least one-fourth of the concrete thickness, to match jointing of existing adjacent concrete paving:
- E. Edging: After initial floating, tool edges of paving, gutters, curbs, and joints in concrete with an edging tool to a 1/4-inch (6-mm) radius. Repeat tooling of edges after applying surface finishes. Eliminate edging-tool marks on concrete surfaces.

3.6 CONCRETE PLACEMENT

- A. Moisten subbase to provide a uniform dampened condition at time concrete is placed. Do not place concrete around manholes or other structures until they are at required finish elevation and alignment.
- B. Comply with ACI 301 (ACI 301M) requirements for measuring, mixing, transporting, and placing concrete.
- C. Deposit and spread concrete in a continuous operation between transverse joints. Do not push or drag concrete into place or use vibrators to move concrete into place.
- D. Screed paving surface with a straightedge and strike off.
- E. Commence initial floating using bull floats or darbies to impart an open-textured and uniform surface plane before excess moisture or bleedwater appears on the surface. Do not further disturb concrete surfaces before beginning finishing operations or spreading surface treatments.

3.7 FLOAT FINISHING

- A. General: Do not add water to concrete surfaces during finishing operations.
- B. Float Finish: Begin the second floating operation when bleedwater sheen has disappeared and concrete surface has stiffened sufficiently to permit operations. Float surface with power-driven floats or by hand floating if area is small or inaccessible to power units. Finish surfaces to true planes. Cut down high spots and fill low spots. Rfloat surface immediately to uniform granular texture.

1. Medium-to-Coarse-Textured Broom Finish: Provide a coarse finish by striating float-finished concrete surface **1/16 to 1/8 inch (1.6 to 3 mm)** deep with a stiff-bristled broom, perpendicular to line of traffic.
- C. Slip-Resistive Aggregate Finish: Before final floating, spread slip-resistive aggregate finish on paving surface according to manufacturer's written instructions.
 1. Cure concrete with curing compound recommended by slip-resistive aggregate manufacturer. Apply curing compound immediately after final finishing.
 2. After curing, lightly work surface with a steel-wire brush or abrasive stone and water to expose nonslip aggregate.

3.8 CONCRETE PROTECTION AND CURING

- A. General: Protect freshly placed concrete from premature drying and excessive cold or hot temperatures.
- B. Comply with ACI 306.1 for cold-weather protection.
- C. Evaporation Retarder: Apply evaporation retarder to concrete surfaces if hot, dry, or windy conditions cause moisture loss approaching **0.2 lb/sq. ft. x h (1 kg/sq. m x h)** before and during finishing operations. Apply according to manufacturer's written instructions after placing, screeding, and bull floating or darbying concrete but before float finishing.
- D. Begin curing after finishing concrete but not before free water has disappeared from concrete surface.
- E. Curing Methods: Cure concrete by moisture-retaining-cover curing curing compound or a combination of these.

3.9 PAVING TOLERANCES

- A. Comply with tolerances in **ACI 117 (ACI 117M)** and as follows:
 1. Elevation: **3/4 inch (19 mm)**.
 2. Thickness: Plus **3/8 inch (10 mm)**, minus **1/4 inch (6 mm)**.
 3. Surface: Gap below **10-feet- (3-m-)** long; unlevelled straightedge not to exceed **1/2 inch (13 mm)**.
 4. Joint Spacing: **3 inches (75 mm)**.
 5. Contraction Joint Depth: Plus **1/4 inch (6 mm)**, no minus.
 6. Joint Width: Plus **1/8 inch (3 mm)**, no minus.

3.10 REPAIR AND PROTECTION

- A. Remove and replace concrete paving that is broken, damaged, or defective or that does not comply with requirements in this Section. Remove work in complete sections from joint to joint unless otherwise approved by Architect.

- B. Protect concrete paving from damage. Exclude traffic from paving for at least 14 days after placement. When construction traffic is permitted, maintain paving as clean as possible by removing surface stains and spillage of materials as they occur.
- C. Maintain concrete paving free of stains, discoloration, dirt, and other foreign material. Sweep paving not more than two days before date scheduled for Substantial Completion inspections.

END OF SECTION 321313

SECTION 321713 - PARKING BUMPERS

PART 1 - GENERAL

1.1 SUMMARY

- A. Section Includes:
1. Precast concrete wheel stops.
 2. Resilient wheel stops.

1.2 ACTION SUBMITTALS

- A. Product Data:
1. Precast concrete wheel stops.
 2. Resilient wheel stops.
- B. Sustainable Design Submittals:

PART 2 - PRODUCTS

2.1 PARKING BUMPERS

- A. Precast Concrete Wheel Stops: Precast, steel-reinforced, air-entrained concrete; **4000-psi (27.6-MPa)** minimum compressive strength; **4-1/2 inches (115 mm)** high by **9 inches (225 mm)** wide by **72 inches (1800 mm)** long. Provide chamfered corners, transverse drainage slots on underside, and a minimum of three factory-formed or -drilled vertical holes through wheel stop for anchoring to substrate.
1. Surface Appearance: Smooth, free of pockets, sand streaks, honeycombs, and other obvious defects. Corners shall be uniform, straight, and sharp.
 2. Surface Sealer: Manufacturer's standard salt-resistant, clear sealer, applied at precasting location.
 3. Mounting Hardware: Galvanized-steel spike or dowel, **1/2-inch (13-mm)** diameter, **14-inch (350-mm)** minimum length or lag screw, shield, and washers; **1/2-inch (13-mm)** diameter, **8-inch (203-mm)** minimum length or hardware as standard with wheel-stop manufacturer.

PART 3 - EXECUTION

3.1 INSTALLATION

- A. Verify that pavement is in suitable condition to begin installation in accordance with manufacturer's written instructions.

- B. Install wheel stops in accordance with manufacturer's written instructions unless otherwise indicated.
- C. Install wheel stops in bed of adhesive before anchoring to substrate.
- D. Securely anchor wheel stops to substrate with hardware in each preformed vertical hole in wheel stop as recommended in writing by manufacturer. Recess head of hardware beneath top of wheel stop.

END OF SECTION 321713

SECTION 321723 - PAVEMENT MARKINGS

PART 1 - GENERAL

1.1 SUMMARY

A. Section Includes:

1. Painted markings applied to asphalt paving.
2. Painted markings applied to concrete surfaces.

1.2 PREINSTALLATION MEETINGS

1.3 ACTION SUBMITTALS

A. Product Data:

1. Pavement-marking paint, solvent-borne.
2. Pavement-marking paint, acrylic.
3. Pavement-marking paint, latex.

PART 2 - PRODUCTS

2.1 MANUFACTURERS

2.2 PERFORMANCE REQUIREMENTS

- ##### A. Accessibility Standard: Comply with applicable provisions in the USDOJ's "2010 ADA Standards for Accessible Design" and ICC A117.1.

2.3 PAVEMENT-MARKING PAINT

A. Pavement-Marking Paint, Solvent-Borne: MPI #32, solvent-borne traffic-marking paint.

1. Color: White, Yellow and Blue.

B. Pavement-Marking Paint, Acrylic: Acrylic, waterborne emulsion, lead and chromate free, ready mixed, complying with FS TT-P-1952F, Type II, with drying time of less than 45 minutes.

1. Color: White, Yellow and Blue.

C. Pavement-Marking Paint, Latex: MPI #97, latex traffic-marking paint.

1. Color: White, Yellow and Blue.

PART 3 - EXECUTION

3.1 PAVEMENT MARKING

- A. Do not apply pavement-marking paint until layout, colors, and placement have been verified with Architect.
- B. Allow asphalt paving or concrete surfaces to age for a minimum of 30 days before starting pavement marking.
- C. Sweep and clean surface to eliminate loose material and dust.
- D. Apply paint with mechanical equipment to produce pavement markings, of dimensions indicated, with uniform, straight edges. Apply at manufacturer's recommended rates to provide a minimum wet film thickness of 15 mils (0.4 mm).
 1. Apply graphic symbols and lettering with paint-resistant, die-cut stencils, firmly secured to asphalt paving or concrete surface.

END OF SECTION 321723

SECTION 323113 - CHAIN LINK FENCES AND GATES

PART 1 - GENERAL

1.1 SUMMARY

- A. Section Includes:
 - 1. Chain-link fences.
 - 2. Swing gates.

1.2 PREINSTALLATION MEETINGS

- A. Preinstallation Conference: Conduct conference at Project site.

1.3 ACTION SUBMITTALS

- A. Product Data: For each type of product.
- B. Shop Drawings: For each type of fence and gate assembly.
 - 1. Include plans, elevations, sections, details, and attachments to other work.
- C. Samples: For each exposed product and for each color and texture specified.

1.4 INFORMATIONAL SUBMITTALS

- A. Product certificates.
- B. Product test reports.
- C. Sample warranty.

1.5 WARRANTY

- A. Special Warranty: Manufacturer agrees to repair or replace components of chain-link fences and gates that fail in materials or workmanship within specified warranty period.
 - 1. Warranty Period: Five years from date of Substantial Completion.

PART 2 - PRODUCTS

2.1 CHAIN-LINK FENCE FABRIC

- A. General: Provide fabric in one-piece heights measured between top and bottom of outer edge of selvage knuckle or twist according to "CLFMI Product Manual" and requirements indicated below:
1. Fabric Height: As indicated on Drawings.
 2. Steel Wire for Fabric: Wire diameter of **0.148 inch (3.76 mm)**.
 - a. Mesh Size: **2 inches (50 mm)**.
 - b. Zinc-Coated Fabric: ASTM A392, Type II, Class 1, **1.2 oz./sq. ft. (366 g/sq. m)** with zinc coating applied before weaving.
 - c. Coat selvage ends of metallic-coated fabric before the weaving process with manufacturer's standard clear protective coating.
 3. Selvage: Twisted top and knuckled bottom.

2.2 FENCE FRAMEWORK

- A. Posts and Rails: ASTM F1043 for framework, including rails, braces, and line; terminal; and corner posts. Provide members with minimum dimensions and wall thickness according to ASTM F1043 or ASTM F1083 based on the following:
1. Fence Height: **72 inches (1830 mm)**.
 2. Light-Industrial-Strength Material: Group IC-L, round steel pipe, electric-resistance-welded pipe.
 - a. Line Post: 2.5 inches (63.5 mm) in diameter.
 3. Horizontal Framework Members: Intermediate rails according to ASTM F1043.
 4. Metallic Coating for Steel Framework:
 - a. Type A zinc coating.

2.3 TENSION WIRE

- A. Metallic-Coated Steel Wire: **0.177-inch- (4.5-mm-)** diameter, marcelled tension wire according to ASTM A817 or ASTM A824, with the following metallic coating:
1. Type II: Zinc coated (galvanized) with minimum coating weight matching chain-link fabric coating weight.

2.4 SWING GATES

- A. General: ASTM F900 for gate posts and double swing gate types.

1. Gate Leaf Width: As indicated on drawings.
 2. Framework Member Sizes and Strength: Based on gate fabric height of 72 inches (1830 mm) or less.
- B. Pipe and Tubing:
1. Zinc-Coated Steel: ASTM F1043 and ASTM F1083; manufacturer's standard protective coating and finish.
 2. Gate Posts: Round tubular steel.
 3. Gate Frames and Bracing: Round tubular steel.
- C. Frame Corner Construction: assembled with corner fittings.
- D. Extended Gate Posts and Frame Members: Fabricate gate posts and frame end members to extend as indicated above top of chain-link fabric at both ends of gate frame to attach barbed wire assemblies.
- E. Hardware:
1. Hinges: 360-degree inward and outward swing.
 2. Latch: Permitting operation from both sides of gate with provision for padlocking accessible from both sides of gate.

2.5 HORIZONTAL-SLIDE GATES

- A. General: ASTM F1184 for gate posts and single] sliding gate types.
1. Classification: Type II Cantilever Slide, Class 2 with internal roller assemblies.
 - a. Gate Frame Width and Height: More than 48 inches (1220 mm) wide by any height.
- B. Pipe and Tubing:
1. Zinc-Coated Steel: Protective coating and finish to match fence framework.
 2. Aluminum: ASTM B429/B429M; manufacturer's standard finish.
 3. Gate Posts: ASTM F1184. Provide round tubular aluminum posts.
 4. Gate Frames and Bracing: Round tubular aluminum.
- C. Frame Corner Construction: Welded or assembled with corner fittings.
- D. Extended Gate Posts and Frame Members: Extend gate posts and frame end members above top of chain-link fabric at both ends of gate frame 12 inches (300 mm) as required to attach barbed wire assemblies.
- E. Overhead Track Assembly: Manufacturer's standard track, with overhead framework supports, bracing, and accessories, engineered to support size, weight, width, operation, and design of gate and roller assemblies.
- F. Hardware:

1. Hangers, Roller Assemblies, and Stops: Fabricated from galvanized steel.
2. Latch: Permitting operation from both sides of gate with provision for padlocking accessible from both sides of gate.
3. Lock: Manufacturer's standard internal device.

2.6 FITTINGS

- A. Provide fittings according to ASTM F626.
- B. Barbed Wire Arms: Pressed steel or cast iron, with clips, slots, or other means for attaching strands of barbed wire, and means for attaching to posts, integral with post cap, for each post unless otherwise indicated, and as follows:
 1. Provide line posts with arms that accommodate top rail or tension wire.
 2. Provide corner arms at fence corner posts unless extended posts are indicated.
 3. Single-Arm Type: Type II, vertical arm.
- C. Finish:
 1. Metallic Coating for Pressed Steel or Cast Iron: Not less than 1.2 oz./sq. ft. (366 g/sq. m) of zinc.
 - a. Polymer coating over metallic coating.

2.7 BARBED WIRE

- A. Steel Barbed Wire: ASTM A121, three-strand barbed wire, 0.099-inch- (2.51-mm-) diameter line wire with 0.080-inch- (2.03-mm-) diameter, four-point round barbs spaced not more than 5 inches (127 mm) o.c.
 1. Zinc Coating: Type Z, Class 3.

2.8 GROUT AND ANCHORING CEMENT

- A. Nonshrink, Nonmetallic Grout: Factory-packaged, nonstaining, noncorrosive, nongaseous grout complying with ASTM C1107/C1107M. Provide grout, recommended in writing by manufacturer, for exterior applications.
- B. Anchoring Cement: Factory-packaged, nonshrink, nonstaining, hydraulic-controlled expansion cement formulation for mixing with water at Project site to create pourable anchoring, patching, and grouting compound. Provide formulation that is resistant to erosion from water exposure without needing protection by a sealer or waterproof coating, and that is recommended in writing by manufacturer for exterior applications.

PART 3 - EXECUTION

3.1 EXAMINATION

- A. Do not begin installation before final grading is completed unless otherwise permitted by Architect.

3.2 PREPARATION

- A. Stake locations of fence lines, gates, and terminal posts. Do not exceed intervals of **500 feet (152 m)** or line of sight between stakes. Indicate locations of utilities, lawn sprinkler system, underground structures, benchmarks, and property monuments.

3.3 CHAIN-LINK FENCE INSTALLATION

- A. Install chain-link fencing according to ASTM F567 and more stringent requirements specified.
- B. Post Excavation: Drill or hand-excavate holes for posts to diameters and spacings indicated, in firm, undisturbed soil.
- C. Post Setting: Set posts in concrete at indicated spacing into firm, undisturbed soil.
 - 1. Verify that posts are set plumb, aligned, and at correct height and spacing, and hold in position during setting with concrete or mechanical devices.
 - 2. Concrete Fill: Place concrete around posts to dimensions indicated and vibrate or tamp for consolidation. Protect aboveground portion of posts from concrete splatter.
 - a. Exposed Concrete: Extend **2 inches (50 mm)** above grade; shape and smooth to shed water.
- D. Terminal Posts: Install terminal end, corner, and gate posts according to ASTM F567 and terminal pull posts at changes in horizontal or vertical alignment of as indicated on Drawings. For runs exceeding **500 feet (152 m)**, space pull posts an equal distance between corner or end posts.
- E. Line Posts: Space line posts uniformly at **10 feet (3 m)** o.c.
- F. Tension Wire: Install according to ASTM F567, maintaining plumb position and alignment of fence posts. Pull wire taut, without sags. Fasten fabric to tension wire with **0.120-inch- (3.05-mm-)** diameter hog rings of same material and finish as fabric wire, spaced a maximum of **24 inches (610 mm)** o.c. Install tension wire in locations indicated before stretching fabric. Provide horizontal tension wire at the following locations:
 - 1. [As indicated on Drawings.
- G. Chain-Link Fabric: Apply fabric to outside of enclosing framework. Leave **2-inch (50-mm)** bottom clearance between finish grade or surface and bottom selvage unless otherwise indicated. Pull fabric taut and tie to posts, rails, and tension wires. Anchor to framework so fabric remains under tension after pulling force is released.

- H. Barbed Wire: Install barbed wire uniformly spaced as indicated on Drawings. Pull wire taut, install securely to extension arms, and secure to end post or terminal arms.

3.4 GATE INSTALLATION

- A. Install gates according to manufacturer's written instructions, level, plumb, and secure for full opening without interference. Attach fabric as for fencing. Attach hardware using tamper-resistant or concealed means. Install ground-set items in concrete for anchorage. Adjust hardware for smooth operation.

3.5 ADJUSTING

- A. Gates: Adjust gates to operate smoothly, easily, and quietly, free of binding, warp, excessive deflection, distortion, nonalignment, misplacement, disruption, or malfunction, throughout entire operational range. Confirm that latches and locks engage accurately and securely without forcing or binding.
- B. Lubricate hardware and other moving parts.

END OF SECTION 323113